

**Syntron** Material Handling

**Syntron®**  
**Vibrating Screens**  
*Advanced Technology for  
Performance Excellence*



# Contents

Syntron® Vibrating Screens

Syntron Material Handling	
Proven Engineered Products – Complete Material Handling Solutions .....	3
UP, VC & NRM Screens .....	11
CS, CH, RVS & BA Screens .....	11
SS & SG Screens .....	25
Screen Options .....	31
Foundry Shakeouts .....	32
Grizzly Bar Screens .....	34



# Syntron Material Handling

## Proven Engineered Products – Complete Material Handling Solutions

Two powerful industry leading brands—**Link-Belt®** and **Syntron®**—have come together under a new company name, Syntron Material Handling, LLC, for one goal – better engineered products.

Established in May 2014, Syntron Material Handling (SMH) was built out of the legacies of Link-Belt® Company and Syntron Company, formerly owned by Syntron Material Handling. Today, our 300 skilled employees have a combined 4,212 years of industry knowledge that they put into the SMH product every day. We are dedicated to providing customers with complete material handling solutions.

Let Syntron Material Handling’s knowledgeable team help your business with conveying, feeding, screening, elevating, vibratory flow aids, and mining controls of bulk product. Whether optimizing existing systems or starting from the ground-up on new and customized plants or mines, our dedicated staff will provide you with the most efficient and cost-effective solutions.

*“Our company structure will be very exciting and fast-paced as we charter our new path. The positive attitudes and skills of our employees, the strength of our products, and our long-term customer relationships are our foundation for success.”* said CEO Andy Blanchard.

An international leader for innovative solutions, Syntron Material Handling can improve the technology customers are already using. The Link-Belt® expertise and equipment have been instrumental in developing some of the world’s largest belt conveyors. The Syntron® feeders are instrumental to supplying energy sources and material handling efforts across the globe.

Levine Leichtman Capital Partners, the new owner of Syntron Material Handling, is committed to the success and growth of the company by investing in engineering capabilities, manufacturing efficiency, and customer service.

Although we may have a new name, we still have the same dedicated employees and industry leading engineered products that make us a market leader.

Syntron Material Handling operates two manufacturing facilities in the USA and China.

All of our products are produced to OSHA/MSHA standards and ISO Standard 9001:2008. We are a charter member of CEMA, and active members of NSSGA, NMA, SME, FEMA, and PMMI.



**Call us today for all your material handling needs.**

**Saltillo**  
2730 Hwy 145 South  
Saltillo, Mississippi 38866  
Phone: 662.869.5711  
Fax: 662.869.7493  
**800.356.4898**  
orders@syntronmh.com

**Changshu**  
#2 Road No. 1  
Changshu Export Processing Zone  
Changshu, Jiangsu, China 215513  
Phone: +86 0512.52299002  
Fax: +86 0512.52297228

# Link-Belt® Models UP, VC & NRM Inclined Vibrating Screens

**For separating solids from liquids and  
sizing light, fine materials.**

Link-Belt® Models UP, VC and NRM Inclined Vibrating Screens are backed with over 50 years of proven, dependable performance in industry. Continuing Vibrating Screen design improvements by our research and development engineers have enabled these rugged units to solve a greater range of difficult screening problems more effectively and economically. There is a Vibrating Screen type and model for every material characteristic, operating condition and capacity requirement.

- Model UP Vibrating Screens assure accurate scalping or sizing of light or fine materials.
- Model VC Vibrating Screens provide fast, effective dewatering in sanitary food processing operations.
- Model NRM Vibrating Screens quickly and easily separate solids from liquids.

Rugged Vibrating Screen vibrators assure efficient, trouble-free service. Vigorous high-speed elliptical vibration keeps loads lively, speeds separation and minimizes plugging or blinding. Vibrators can be easily adjusted to varying material characteristics by changing the position of the unbalanced weights in relation to the eccentric shaft. Vibrator parts seldom need replacement, even after years of operation. When routine maintenance is required, it can be performed with minimum downtime since they can be quickly detached from the Vibrating Screen frame.



Single-deck NRM dewatering screen at a fish hatchery.

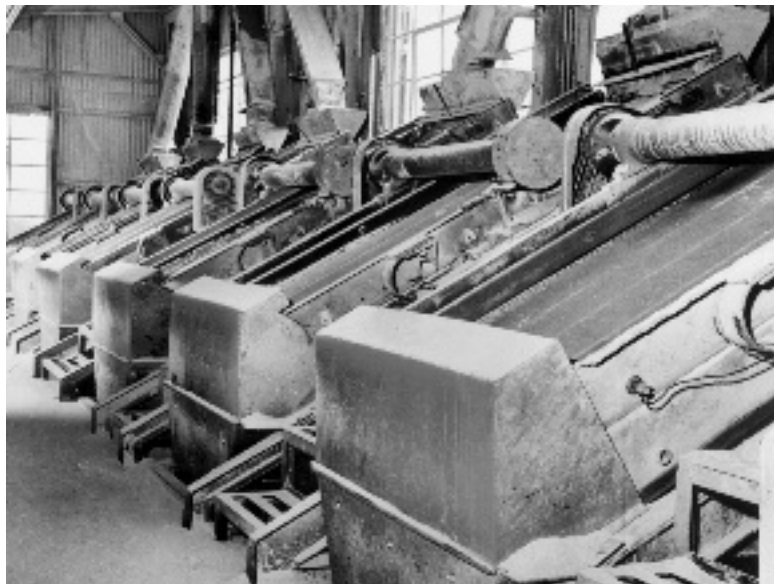

Model UP-248 vibrating screens. Proven service in the manufacture of firebrick for over 50 years.

# Model UP Sizing and Scalping Screen

**Foundries, mining installations, feed mills, fertilizer plants, brick plants, quarries and many other industries.**

Available with one or two decks, the **Model UP** is designed for fast, accurate sizing or scalping and uniform distribution of light or fine materials.

Fully enclosed units can be furnished for processing dusty, corrosive or toxic materials. In this exclusive design, the enclosure is totally isolated from vibration to preserve its structural integrity. Enclosures are supplied complete with feed chute, discharge chute and collecting hopper.

The **Model UP** vibrator provides vigorous, high-speed elliptical motion. This vibrating action keeps loads lively, speeds separation and reduces plugging or blinding. To field-adjust the vibrator for changing material characteristics, simply vary the position of the unbalanced weights in relation to the eccentric shaft.

The vibrator's self-aligning, spherical roller bearings are cartridge mounted for protection from dirt, corrosives and moisture. Each sealed cartridge has a channel leading to the bearing for easy, direct grease lubrication. Vibrators can be quickly detached for maintenance by the simple removal of ten high-strength bolts.

This model can be furnished with an electrically heated screen cloth to prevent blinding when screening materials with a high moisture content.

Bouncing ball decks can be supplied for screening materials with a high percentage of near-size particles.



Model UP-2410 handling limestone in a sizing operation at crushing plant.

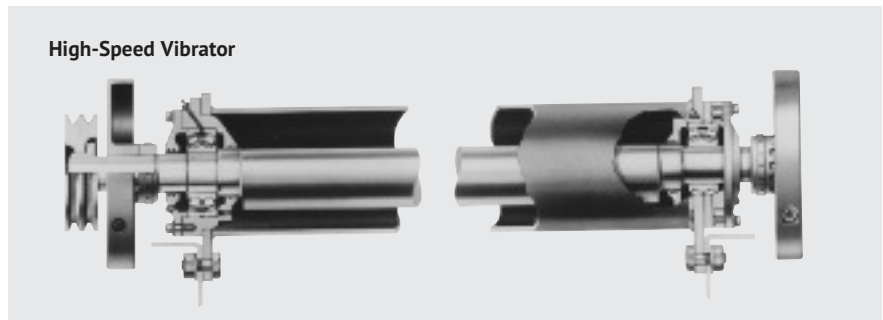

**Model UP**

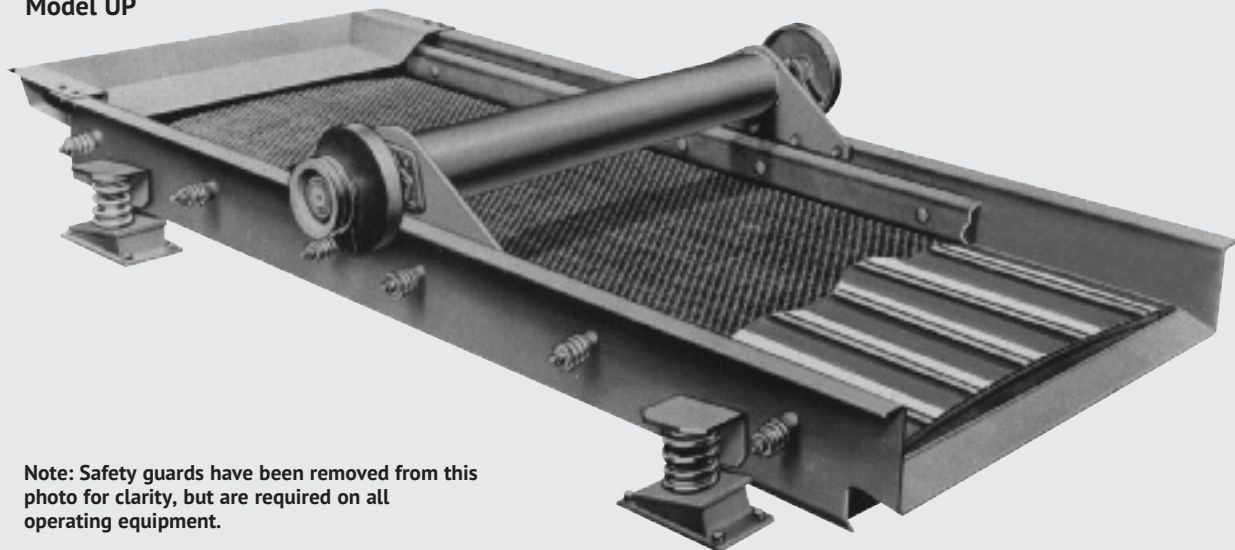

**Note: Safety guards have been removed from this photo for clarity, but are required on all operating equipment.**



# Model UP Sizing and Scalping Screen (continued)

**Model UP  
one deck, enclosed ▲**

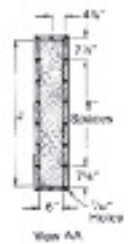
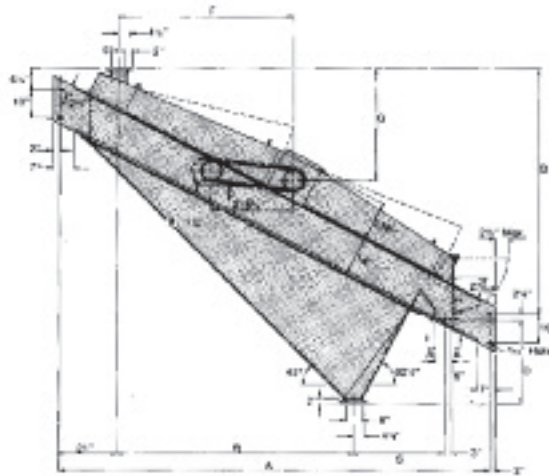
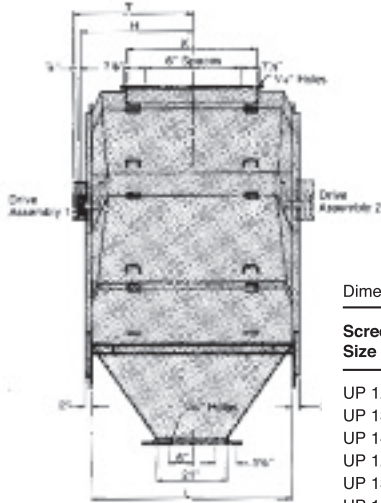

Dimensions in inches

Screen Size	HP	Weight pounds	A	B	D	F	G	H	J	K	L	R	S	T
UP 124E	2	1490	88	52	10	29	22 1/4	25 1/2	30	18	42	29 3/4	21 1/8	27 1/8
UP 134E	2	1730	88	52	10	29	22 1/4	31 1/2	42	30	54	29 3/4	21 1/8	33 1/8
UP 145E	2	2250	98 5/8	57 1/2	13 3/8	34 1/4	25	37 1/2	54	42	66	38 5/8	22 7/8	39 1/8
UP 128E	2	2185	130 5/8	74 1/4	23 1/2	50 1/4	33 1/4	25 1/2	30	18	42	65 1/2	28 1/8	27 1/8
UP 138E	2	2490	130 5/8	74 1/4	23 1/2	50 1/4	33 1/4	31 1/2	42	30	54	65 1/2	28 1/8	33 1/8
UP 148E	2	2835	130 5/8	74 1/4	23 1/2	50 1/4	33 1/4	37 1/2	54	42	66	65 1/2	28 1/8	39 1/8
UP 1410E	3	3510	152	85 1/4	30 1/4	61	38 1/2	37 1/2	54	42	66	83 1/4	31 5/8	39 1/8

▲ Screen may be factory mounted at 25°, 27-1/2°, or 30° within the enclosure.

**Model UP  
two deck, enclosed ▲**

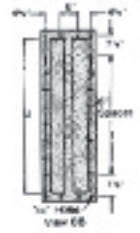
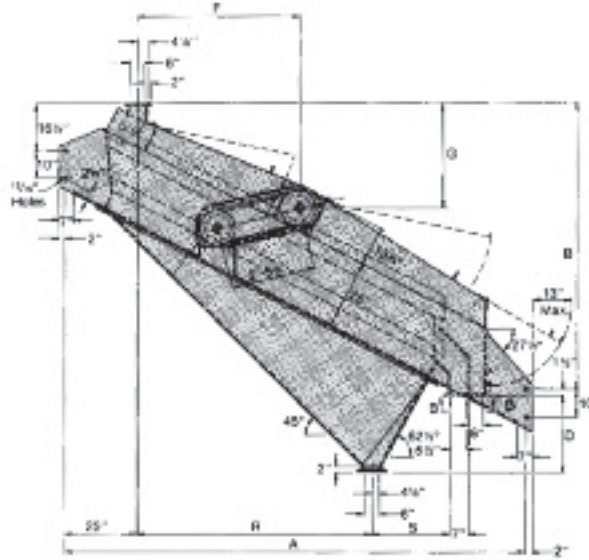
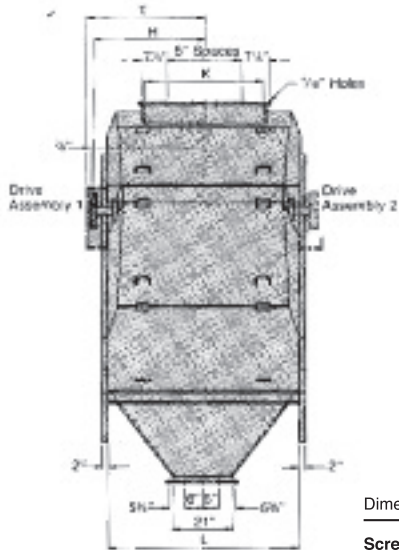

Dimensions in inches

Screen Size	HP	Weight pounds	A	B	D	F	G	H	J	K	L	R	S	T
UP 224E	2	2110	98 5/8	67 7/8	7	25 1/2	20	25 1/2	30	18	42	29 3/8	16 5/8	27 1/8
UP 234E	3	2450	98 5/8	67 7/8	7	25 1/2	20	31 1/2	42	30	54	29 3/8	16 5/8	33 1/8
UP 245E	3	3290	109 1/4	73 3/8	10 3/8	30 3/4	22 3/4	37 1/2	54	42	66	38 1/4	18 3/8	39 1/8
UP 228E	2	3080	141 1/4	90	20 1/2	46 3/4	31 1/8	25 1/2	30	18	42	65	23 3/8	27 1/8
UP 238E	3	3530	141 1/4	90	20 1/2	46 3/4	31 1/8	31 1/2	42	30	54	65	23 3/8	33 1/8
UP 248E	3	4060	141 1/4	90	20 1/2	46 3/4	31 1/8	37 1/2	54	42	66	65	23 3/8	39 1/8
UP 2410E	5	4700	162 1/2	101 1/8	27 1/4	57 3/8	36 5/8	37 1/2	54	42	66	82 3/4	27 1/8	39 1/8

▲ Screen may be factory mounted at 25°, 27-1/2°, or 30° within the enclosure.

# Model VC Dewatering Vibrating Screen

**Corn, beans, peas, sprouts, beets, diced meats and many other food products.**

The **Model VC** vibrating screen is designed for fast, sanitary dewatering of vegetables and other food products. The high-speed, unbalanced vibrator provides a smooth flow of material, forming an even bed for inspection.

Depending on the application, the **Model VC** can be supplied with either a welded panel or perforated plate screening surface. This helps maintain sanitation by eliminating material catching tension plates, tension bolts and nuts.

The vibrator features large, self-aligning bearings fully enclosed by labyrinth seals. These seals keep lubricants in, corrosives out.

Spring mountings give the **Model VC** outstanding stability and isolate vibration from the supporting structure.

**High Speed Vibrator**

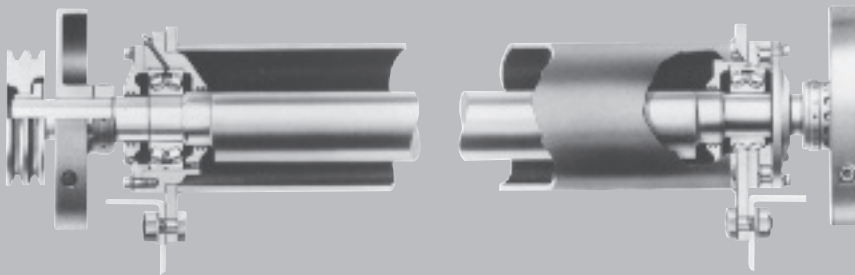

**Model VC**

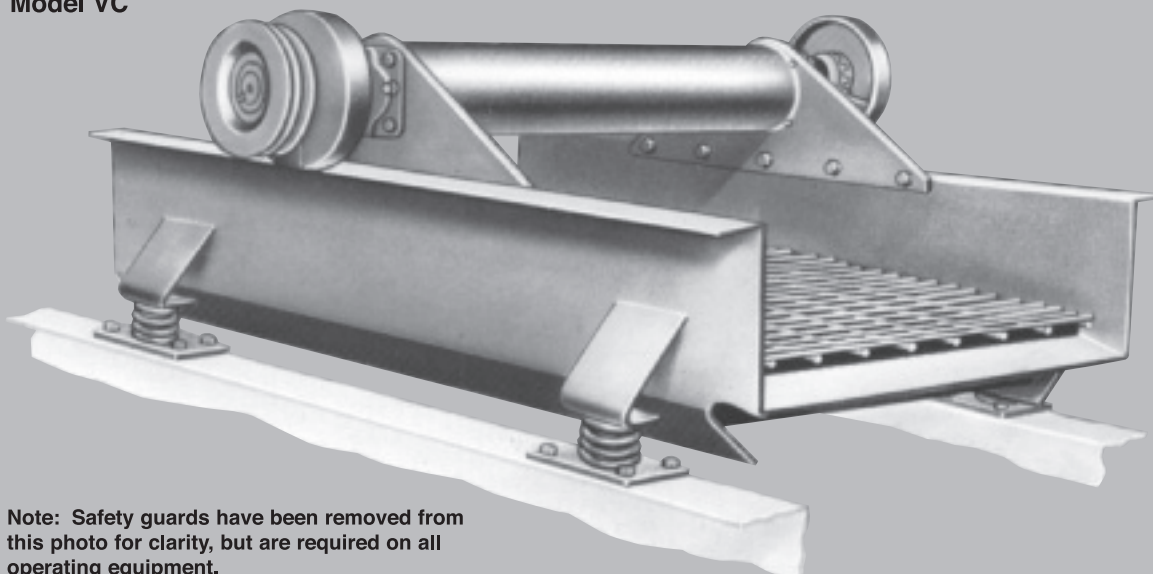

**Note: Safety guards have been removed from this photo for clarity, but are required on all operating equipment.**



# Model NRM Liquid Vibrating Screen

**Canning, meat packing, general food processing, sewage treatment, pulp and paper production, juice and oil extraction, distilling and many other industries.**

**NRM** liquid vibrating screens use fine screen cloths, up to 120 mesh. Maximum liquid passing with minimum blinding is assured. Separation of solids from liquids is highly efficient.

**Model NRM** screens are built for a long, productive life. The screen box and deck are made of welded, low alloy steel, reinforced with heavy-duty pipe. High strength, spring-loaded bolts assure constant tensioning of the screen cloth. A four-point spring suspension effectively isolates vibration from the mounting structure. For maximum cloth life, the fine mesh stainless steel cloth is supported by a cambered deck and cushioned by rubber caps.

Cartridge mounted, self-aligning spherical roller bearings protect the NRM vibrator from dirt, moisture and

corrosives. Each cartridge contains a channel to the center of the bearing for optimum grease lubrication.

Vibrators can be easily adjusted to varying material characteristics by changing the position of the unbalanced weights in relation to the eccentric shaft.

This model is available for horizontal, inclined or declined mounting. It can be supplied with a feed flume, receiving tank and motor supports. Stainless steel screen frames can be furnished for operation in corrosive conditions.

An optional automatic spray cleaner can also be provided to eliminate plugging in processes involving greasy or sticky materials.



Four Link-Belt® Model NRM liquid Vibrating screens dewatering feathers and offal in a chicken processing plant.

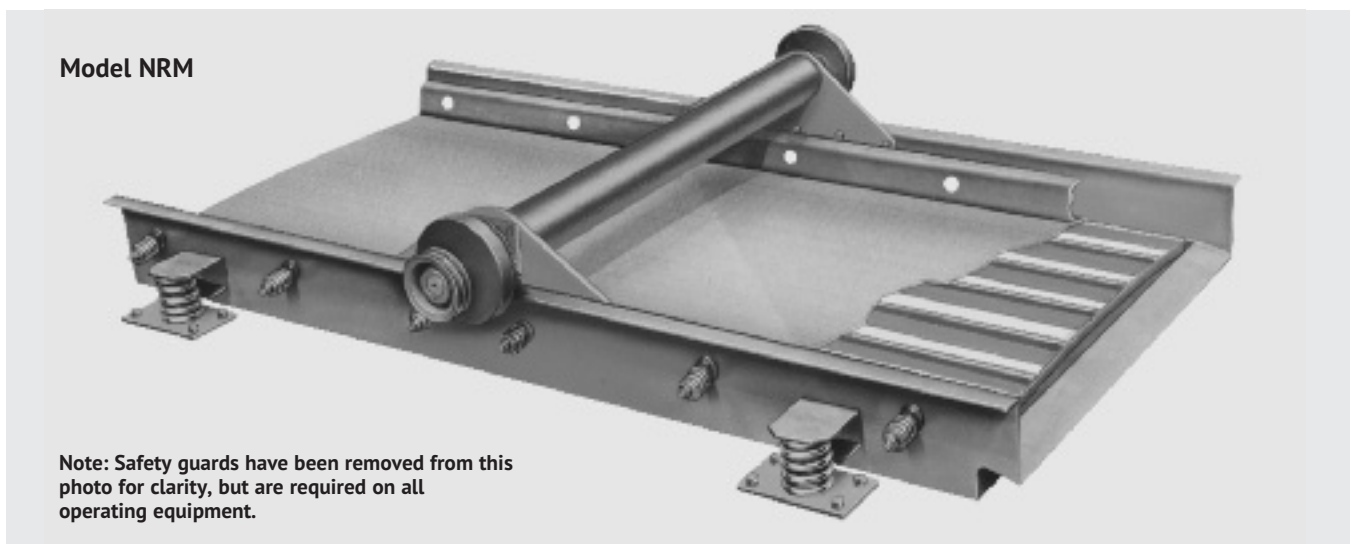
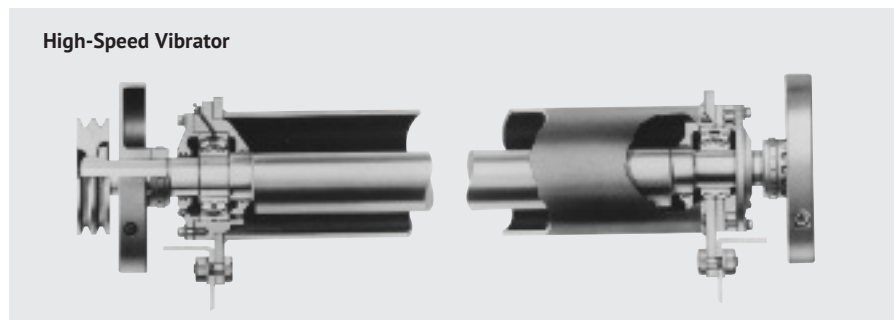

## Model NRM

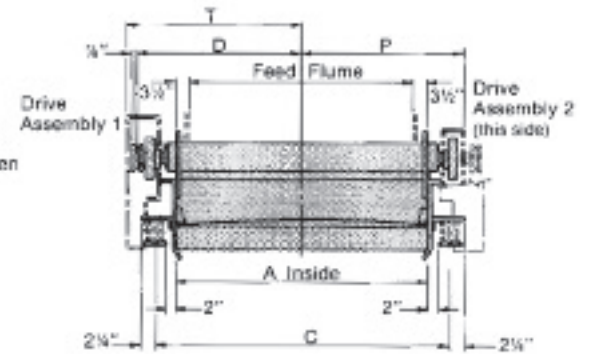
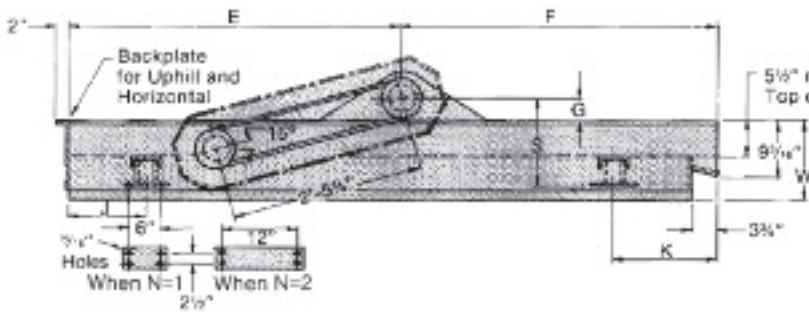

Allow 2" vertical and 1 1/2" horizontal clearance unless otherwise shown.

Dimensions in inches

Screen Size ■	HP	Weight pounds	A	C	D	E	F	G	J	K	N▲	S	W	P	T
NRM 124	2	550	26	34	21 3/8	28	24	3 3/8	9	13	1	13 1/2	12	18 13/16	22 7/8
NRM 134	2	650	38	46	27 3/8	28	24	3 3/8	9	13	1	13 1/2	12	24 13/16	28 7/8
NRM 145	2	890	50	58	33 3/8	34	30	3 3/8	12	13	1	13 1/2	12	30 13/16	34 7/8
NRM 128	2	795	26	34	21 3/8	52	48	3 3/8	12	16	1	13 1/2	12	18 13/16	22 7/8
NRM 138	2	915	38	46	27 3/8	52	48	3 3/8	12	16	1	13 1/2	12	24 13/16	28 7/8
NRM 148	2	1070	50	58	33 3/8	52	48	3 3/8	12	16	1	13 1/2	12	30 13/16	34 7/8
NRM 1410	3	1455	50	58	33 3/8	64	60	3 3/4	12	16	2	14	14	30 13/16	34 7/8

▲ Number of springs per bracket.

■ Stainless steel screen cloth and V-belt drive furnished.

## Model NRM with feed flume, collecting tank and motor support

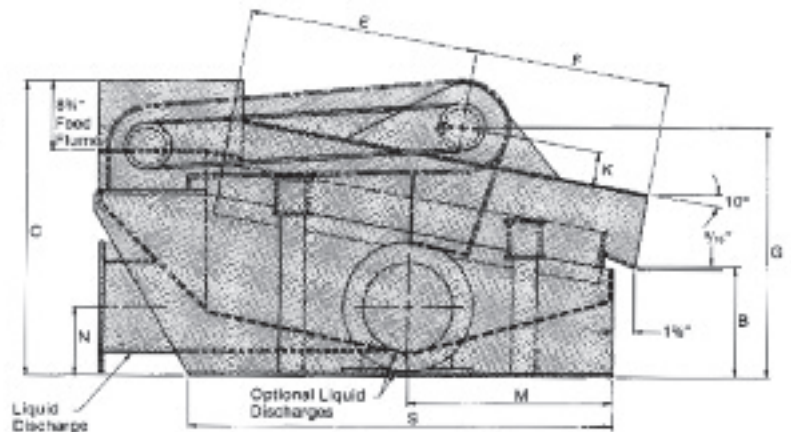
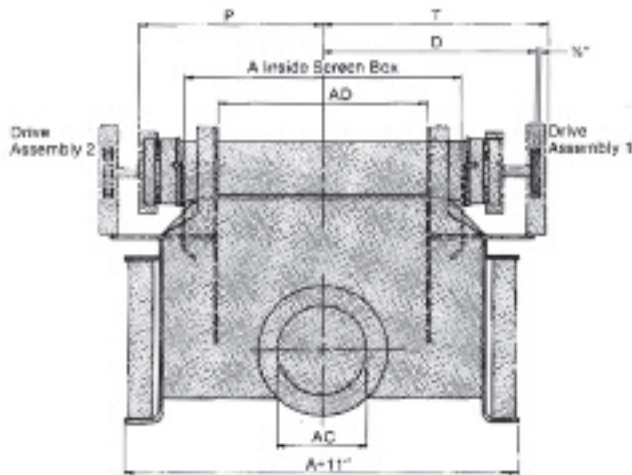

Dimensions in inches

Screen Size ■	HP	Weight pounds	A	B	C	D	E	F	G	K	N	M	S	AC	AD	P	T
NRM 124	2	1200	26	13 3/4	37 1/4	21 3/8	28	24	30 1/2	3 3/8	8 1/4	26	53 1/2	10	15	18 13/16	23 1/4
NRM 134	2	1410	38	13 3/4	37 1/4	27 3/8	28	24	30 1/2	3 3/8	8 1/4	26	53 1/2	10	27	24 13/16	29 1/4
NRM 145	2	2105	50	15 3/4	42	33 3/8	34	30	34	3 3/8	9 3/4	32	65	12	39	30 13/16	35 1/4
NRM 128	2	2230	26	16 1/4	48 1/2	21 3/8	52	48	37	3 3/8	9 3/4	51	99	12	15	18 13/16	23 3/8
NRM 138	2	2525	38	16 1/4	48 1/2	27 3/8	52	48	37	3 3/8	9 3/4	51	99	12	27	24 13/16	29 3/8
NRM 148	2	2855	50	16 1/4	48 1/2	33 3/8	52	48	37	3 3/8	9 3/4	51	99	12	39	30 13/16	35 3/8
NRM 1410	3	3930	50	22 1/2	58 3/4	33 3/8	64	60	45	3 3/4	9 3/4	63	123	12	39	30 13/16	35 3/4

■ Stainless steel screen cloth and V-belt drive furnished.

# Link-Belt® Models CS, CH & BA Syntron® Model RVS Inclined Vibrating Screens

**High tonnage units for sizing and scalping.**

Performance engineered Link-Belt® Models CS, CH and BA and Syntron Model RVS inclined Vibrating Screens assure efficient, dependable operation to solve your most difficult sizing, scalping, dewatering and rinsing applications.

These four ruggedly constructed Vibrating Screen models provide medium and heavy-duty service screening a wide range of materials in the coal, aggregate, asphalt, pulp and paper and chemical handling industries.

- Model RVS Vibrating Screens offer maximum particle segregation of aggregates, chemicals, coal and many other bulk materials.
- Model CS Vibrating screens assure fast, accurate sizing, scalping, dewatering and rinsing of a wide variety of medium size materials.
- Model CH Vibrating Screens provide high tonnage sizing and scalping of medium and large lump size materials.
- Model BA Vibrating Screens are heavy-duty units, designed for fast, economical handling of ore, rock and aggregate.

Years of field testing have proven the high tonnage capabilities of these units. Their rugged vibrators assure a long, trouble-free service life.

Let our Application Specialist guide your choice of Vibrating Screens. Their application experience and the back-up expertise of our in-plant engineers will help you select the most productive cost-effective unit for your needs.



# Model RVS Vibrating Screen

**A rotary vibrator drive unit with maximum screening area for aggregates, chemicals, coal and many other bulk materials.**

**Model RVS** offers you maximum particle segregation. This unit owes its efficiency to an increased screening area and reduced drive and power requirements.

The heart of **Model RVS** is a powerful rotary vibrator drive unit. The rotary vibrator consists of an electric motor with adjustable eccentric weights on each end.

The vibrator's extra-heavy duty bearings are totally enclosed by a dust-tight, water-tight case. Grease lubrication is through easily accessible fittings. Each rotary vibrator is mounted rigidly to the screen frame by six high-strength bolts.

Rotary vibrator drive provides several important advantages compared with eccentric action screens. Rotary vibrators need no separate motor, V-belt, chains, sprockets, or other connections. There can be no slippage with

consequent reduced amplitude and screening capacity. Rotary vibrators can be reversed to increase efficiency in screening low density materials. And rotary vibrators will operate at constant, name-plate-rated speeds for the life of the screen, without adjustment.

Two rotary vibrators are used on RVS units. They range from 9,600 to 20,000 lbs. thrust at frequencies of 900, 1200 and 1800 RPM. Operation can be from either 230, 460 or 550 volts, three phase, 60 cycle a-c, as specified.

**Model RVS**

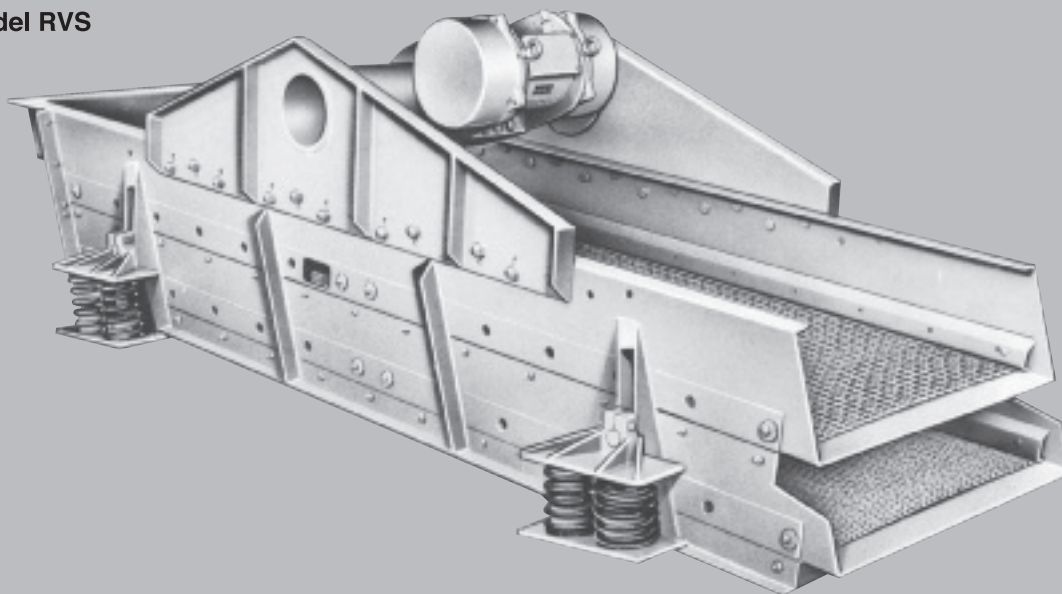

**Rotary  
Vibrator**

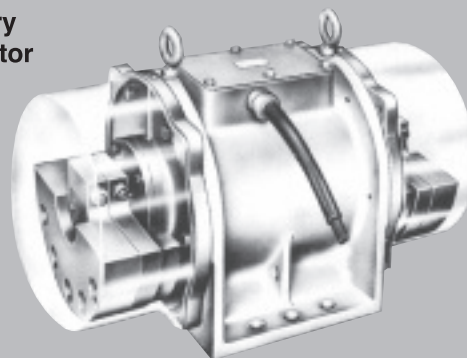

**Model RVS one-deck**

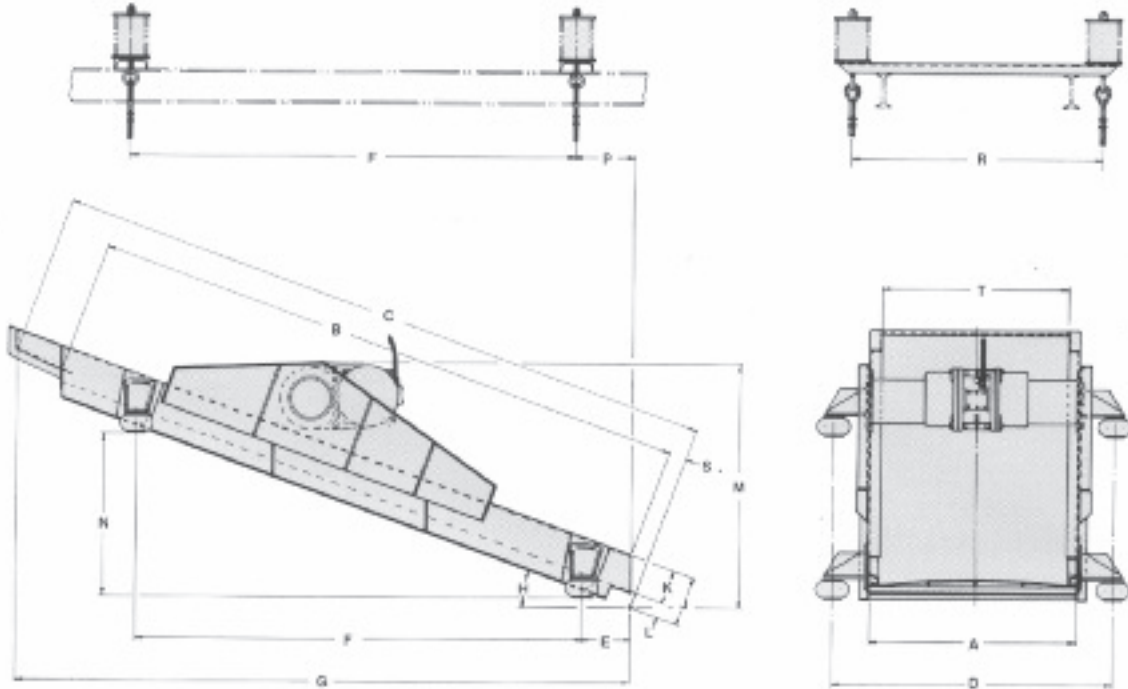

Dimensions in inches

Model	A	B	C	D	E	F	G	H	J	K	L	M	N	P	R	S	T	Net Weight Lbs.
RVS-1410-K	49 1/2	122 1/4	138 5/8	64 1/4	12	95 7/8	127 3/4	20°	12	8 1/4	3 3/4	53 7/8	34 7/8	14 1/4	59 1/2	4 3/8	44 1/2	2500
RVS-1412-K	49 1/2	146 1/4	162 5/8	64 1/4	12	109	150 1/4	20°	12	8 1/4	3 3/4	59	39 3/4	14 1/4	59 1/2	4 3/8	44 1/2	2700
RVS-1510-K	61 1/2	122 1/4	138 5/8	76 1/4	12	95 7/8	127 3/4	20°	12	8 1/4	3 3/4	56	35 1/8	14 1/4	71 1/2	4 3/8	56 1/2	2700
RVS-1512-K	61 1/2	146 1/4	162 5/8	77 1/2	22 3/8	96 1/4	150	20°	12	8 1/4	3 3/4	60 3/4	35	-----	-----	4 3/8	56 1/2	2900
RVS-1612-K	73 1/2	146 1/4	162 5/8	89 1/2	22 3/8	96 1/4	150	20°	12	8 1/4	3 3/4	60 3/4	35	-----	-----	4 3/8	68 1/2	3000
RVS-1614-K & H	73 1/2	170 1/4	186 5/8	89 1/2	21	120	172 1/8	20°	12	8 1/4	3 3/4	64 1/4	43 3/8	-----	-----	4 3/8	68 1/2	4200
RVS-1616-H	73 1/2	193 3/4	210 7/8	89 1/2	34 1/8	120 1/4	198	20°	14	10 1/4	3 3/4	75 1/4	43 3/4	-----	-----	5 1/8	68 1/2	4500



Eight Syntron Model RVS-1512-K vibrating screens equipped with 14-mesh slotted cloth, each producing 25 to 30 TPH of minus 14-mesh fireclay with shale.

# Model RVS Vibrating Screen

Model RVS two-deck

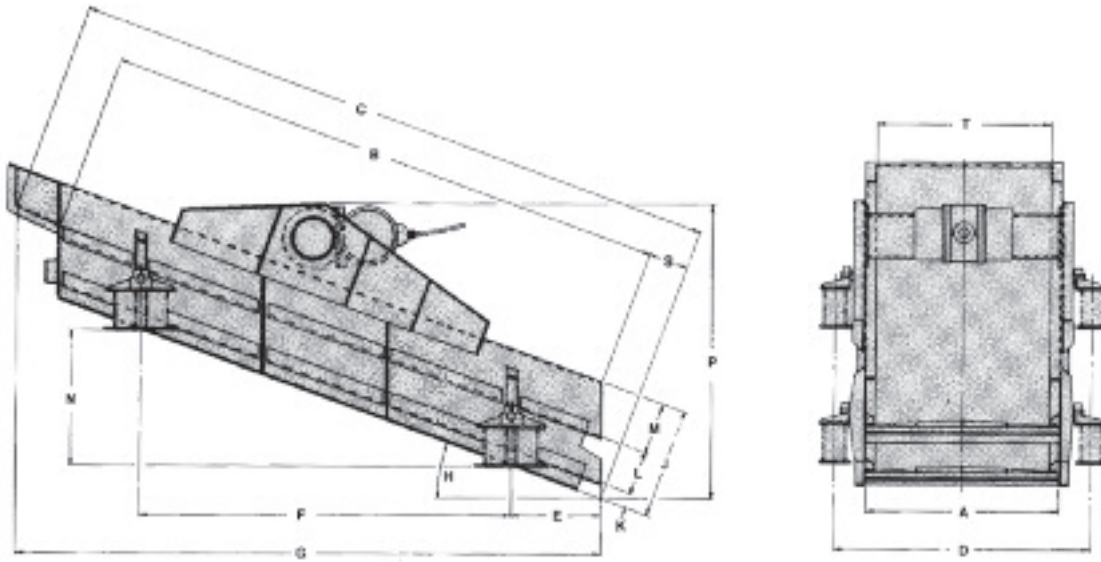

Dimensions in inches

Model	A	B	C	D	E	F	G	H	J	K	L	M	N	P	S	T	Net Weight Lbs.
RVS-248-K	49 1/2	96 5/8	118 7/8	65 1/2	12	70	105 1/8	20°	28	3 3/4	10 7/8	13 3/8	25 1/2	65 1/4	10 1/4	44 1/2	3000
RVS-2310-K	37 1/2	120 5/8	142 7/8	53 1/2	23	72 7/8	127 1/2	20°	28	3 3/4	10 7/8	13 3/8	26 1/2	69 1/4	10 1/4	32 1/2	3200
RVS-2410-K	49 1/2	120 5/8	142 7/8	65 1/2	23	72 7/8	127 1/2	20°	28	3 3/4	10 7/8	13 3/8	26 1/2	71 1/2	10 1/4	44 1/2	3600
RVS-2412-K	49 1/2	144 5/8	166 7/8	65 1/2	23	95	150 1/4	20°	28	3 3/4	10 7/8	13 3/8	34 3/8	74 1/2	10 1/4	44 1/2	3800
RVS-2510-K	61 1/2	120 5/8	142 7/8	77 1/2	23	72 7/8	127 1/2	20°	28	3 3/4	10 7/8	13 3/8	26 1/2	72 1/2	10 1/4	56 1/2	3700
RVS-2512-H	61 1/2	144 5/8	166 7/8	77 1/2	23	95	150 1/4	20°	28	3 3/4	10 7/8	13 3/8	34 3/8	78 1/2	10 1/4	56 1/2	5300
RVS-2612-H	73 1/2	144 5/8	166 7/8	89 1/2	23	95	150 1/4	20°	28	3 3/4	10 7/8	13 3/8	34 3/8	78 1/2	10 1/4	68 1/2	5500
RVS-2614-H	73 1/2	168 5/8	190 7/8	89 1/2	23	108	172 7/8	20°	28	3 3/4	10 7/8	13 3/8	39 3/8	83 7/8	10 1/4	68 1/2	5900

Syntron Model RVS-2510 vibrating screen being operated as a single deck unit screening 150 TPH of gravel through 1 1/2" openings.

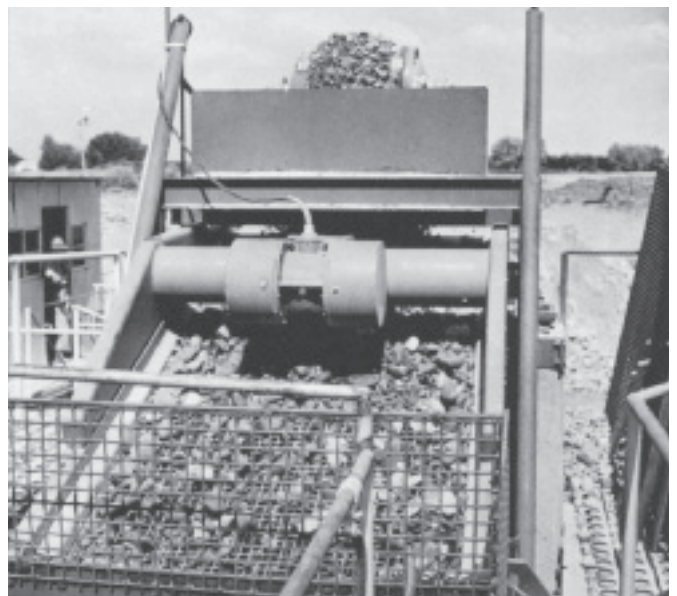

**Model RVS three-deck**

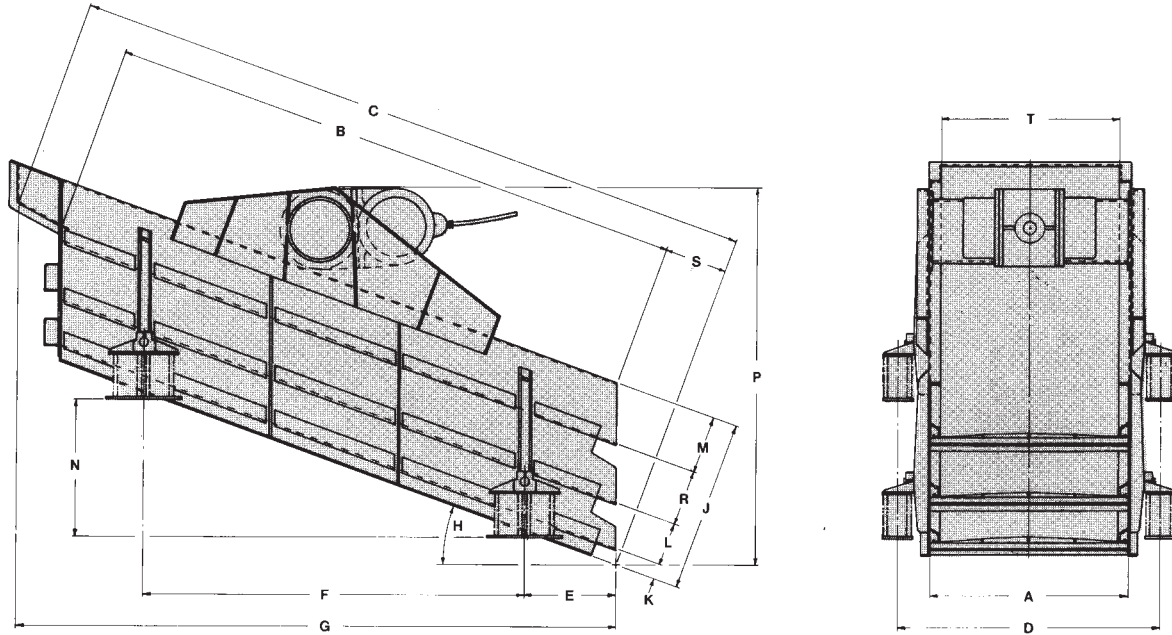

Dimensions in inches

Model	A	B	C	D	E	F	G	H	J	K	L	M	N	P	R	S	T	Net Weight Lbs.
RVS-348-K	49 1/2	95 3/4	123 3/8	65 1/2	23	49 3/8	104 1/2	20°	43	3 3/4	10 3/4	14 1/2	18	82	14	15 5/8	44 1/2	3700
RVS-3410-K	49 1/2	120 1/4	147 7/8	65 1/2	23	72 7/8	127 1/4	20°	43	3 3/4	10 3/4	14 1/2	26 1/2	86	14	15 5/8	44 1/2	4300
RVS-3412-H	49 1/2	144 1/4	171 1/8	65 1/2	23	95 1/4	150	20°	43	3 3/4	10 3/4	14 1/2	34 3/8	94 7/8	14	15 5/8	44 1/2	6000
RVS-3510-H	61 1/2	120 1/4	147 3/8	77 1/2	23	72 7/8	127 1/4	20°	43	3 3/4	10 3/4	14 1/2	26 1/2	90 7/8	14	15 5/8	56 1/2	5900
RVS-3512-H	61 1/2	144 1/2	172 1/8	77 1/2	23	95 1/4	150 1/4	20°	43	3 3/4	10 3/4	14 1/2	34 3/8	94 3/4	14	15 5/8	56 1/2	6500
RVS-3514-H	61 1/2	168 1/4	195 7/8	77 1/2	34 3/4	96 1/2	172 1/2	20°	43	3 3/4	10 3/4	14 1/2	35 1/4	98 3/4	14	15 5/8	56 1/2	6600
RVS-3612-H	73 1/2	144 1/2	172 1/8	89 1/2	23	95 1/4	150 1/4	20°	43	3 3/4	10 3/4	14 1/2	34 3/8	94 3/4	14	15 5/8	68 1/2	6700



Three-deck Syntron Model RVS-3412-H vibrating screen handling 135 TPH of stone and sand, washing with sprays.

# Model CS Vibrating Screen

**For medium to heavy-duty sizing, scalping, dewatering and rinsing. Serving industries that include aggregate, mining, pulp and paper and chemical.**

**Model CS** Vibrating Screens are extremely versatile. Available with a variety of screening surfaces, CS Vibrating Screens assure fast, accurate sizing, scalping, dewatering and rinsing of a wide range of materials such as stone, coal, asphalt, pulp and paper and chemicals. To meet specific processing needs, units can be furnished with one, two or three screening decks.

The model may be mounted in any of several ways; inclined floor mounting, ceiling mounting or combined floor and ceiling mounting. A four-point suspension system efficiently isolates vibration from the supporting structure.

The CS vibrator unit is designed with an oil bath lubrication system to increase bearing service life and reduce costly maintenance. An optional grease lubrication system can be provided if preferred.

The CS vibrator design utilizes two, rugged, self-contained, double roll bearing assemblies. Each double-row, self-aligning spherical roller bearing is cartridge mounted and sealed from abrasive and corrosive materials. Bearings receive direct oil lubrication from housing reservoir.

The improved design of the vibrator off-balance weights permits faster minor stroke adjustment. Vibrator weight guards are furnished as standard equipment. Optional equipment for the Model CS Vibrating Screen includes electrically heated screen cloth, bouncing ball decks and total dust enclosures.



**Model CS vibrator**

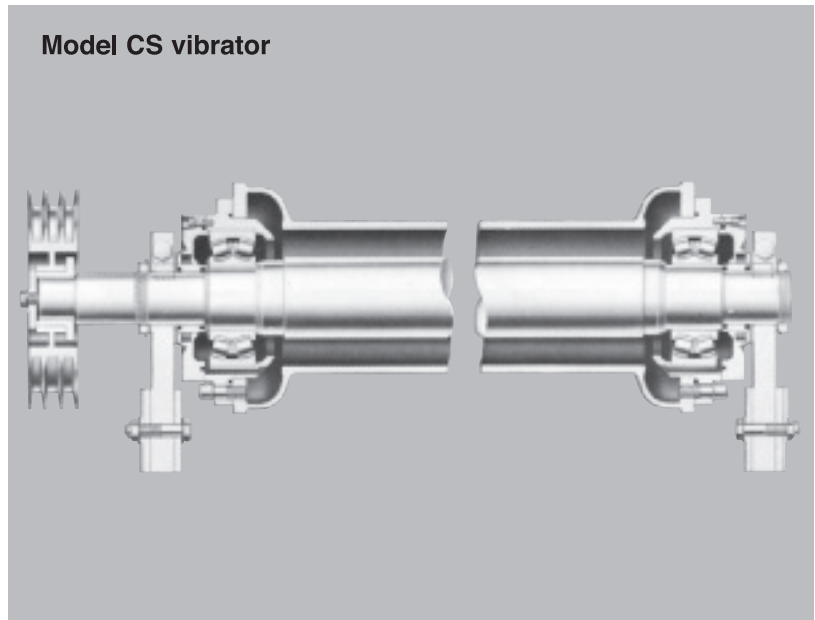



### Model CS one-deck

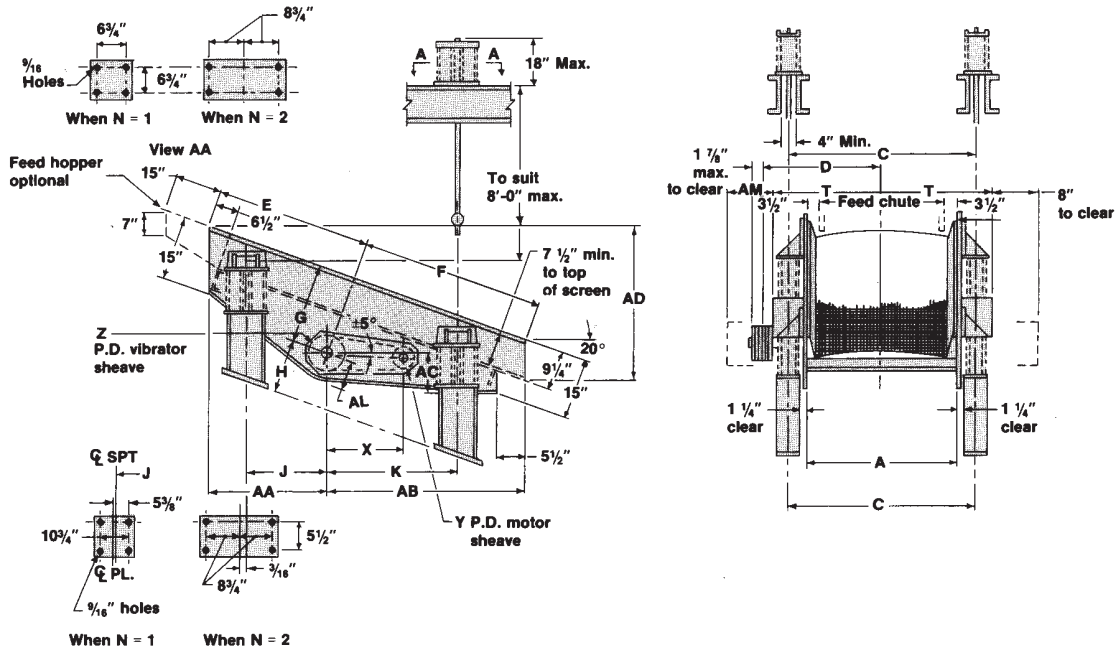

Dimensions in inches

Screen Size	HP	RPM	Vib wt. lbs.	A	C	D	E	F	G	H	J	K	N ▲	T	X	Y	Z	AA	AB	AC	AD	AL	AM
CS148	5	1040	1775	48	58	36 3/16	55 1/2	49 1/4	18 1/4	14	28 7/16	33 9/16	1	31	33 1/4	9.5	16	45 15/16	52 1/2	9 1/2	45 5/8	11	13 1/4
CS1410	5	1040	2000	48	58	36 3/16	67 1/2	61 1/4	18 1/4	13 3/4	39 3/4	44 7/8	1	31	33 1/4	9.5	16	57 3/16	63 3/4	13 3/8	53 7/8	11	13 1/4
CS1412	5	1040	2200	48	58	36 3/16	79 1/2	73 1/8	18 1/4	13 1/2	51	56 1/8	1	31	33 1/4	9.5	16	68 3/8	75 1/16	17 3/4	62 1/16	11	13 1/4
CS1510	5	1040	2250	60	70	42 3/16	67 1/2	61 1/4	18 1/4	13 3/4	39 3/4	44 7/8	1	37	33 1/4	9.5	16	57 3/16	63 3/4	13 3/8	53 7/8	11	13 1/4
CS1512	5	1040	2475	60	70	42 3/16	79 1/2	73 1/8	18 1/4	13 1/2	51	56 1/8	1	37	33 1/4	9.5	16	68 3/8	75 1/16	17 3/4	62 1/16	11	13 1/4
CS1514	5	1040	2800	60	70	42 3/16	91 1/2	85 1/4	18 1/4	17 1/4	62 1/4	67 3/8	2	37	33 1/4	9.5	16	79 3/4	86 3/8	21 7/8	70 1/4	14 1/2	13 1/4
CS1612	5	1040	2825	72	82	48 3/16	79 1/2	73 1/8	18 1/4	14 1/4	51	56 1/8	1	43	33 1/4	9.5	16	68 3/8	75 1/16	17 3/4	62 1/16	11	13 1/4
CS1614	5	1040	3350	72	82	48 3/16	91 1/2	85 1/4	18 1/4	17	62 1/4	67 3/8	2	43	33 1/4	9.5	16	79 3/4	86 3/8	21 7/8	70 1/4	14 1/2	13 1/4
CS1616	5	1040	4150	72	82	48 3/16	103 1/2	97 1/8	18 1/4	18 1/4	73 7/16	78 7/16	2	43	33 1/4	9.5	16	91	97 5/8	26	78 1/2	15 3/4	13 1/4

▲ Number of springs per bracket.

NOTE: All above sizes are available in grease or oil lubrication.

Allow 2" vertical and 1-1/2" horizontal clearance unless otherwise shown.

Have dimensions certified for installation purposes.

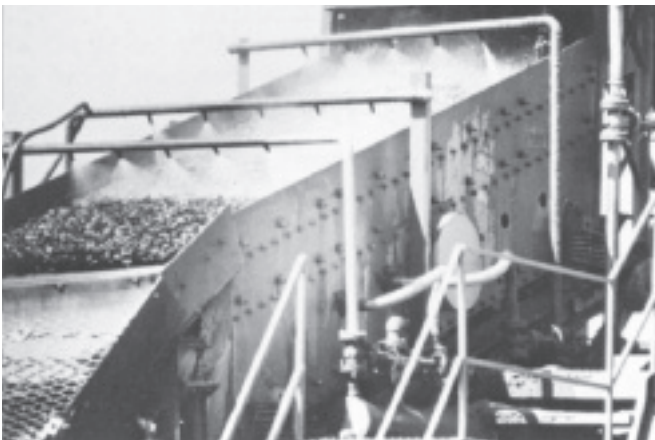

Link-Belt® Model CS-3616 Vibrating Screen handling crushed stone in a quarry.

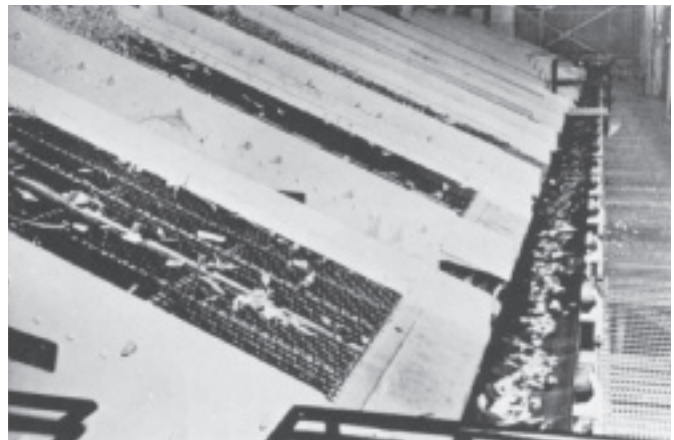

Nine CS Vibrating Screens efficiently handle wood chips.

# Model CS Vibrating Screen

## Model CS two-deck

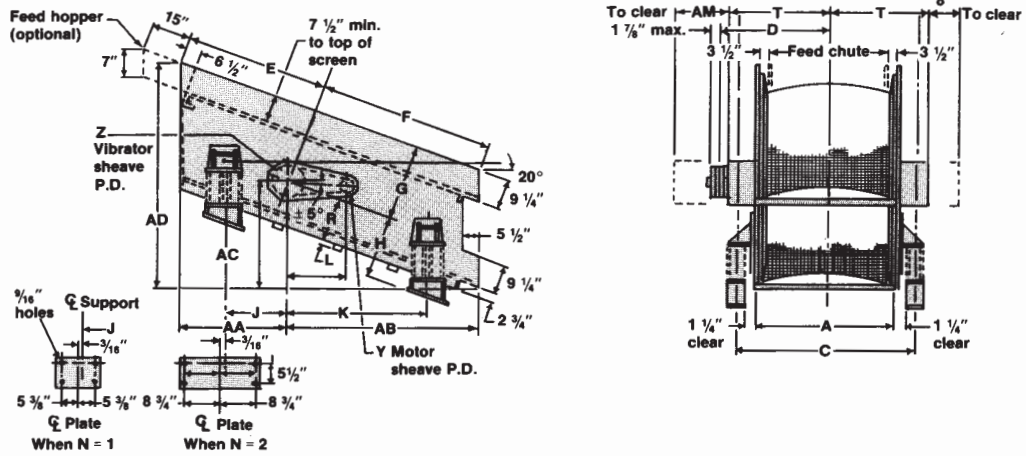

Dimensions in inches

Screen Size	HP	RPM	Vib wt. lbs.	A	C	D	E	F	G	H	J	K	L	N	R	T	X	Y	Z	AA	AB	AC	AD	AM
CS248	5	1040	2625	48	58	36 <sup>3/16</sup>	55 <sup>1/2</sup>	49 <sup>3/4</sup>	18 <sup>1/4</sup>	21	28 <sup>7/16</sup>	33 <sup>3/16</sup>	1 <sup>1/2</sup>	1	16 <sup>1/4</sup>	31	33 <sup>1/4</sup>	9.5	16	45 <sup>7/8</sup>	52 <sup>3/4</sup>	33 <sup>1/2</sup>	69 <sup>5/8</sup>	13 <sup>1/4</sup>
CS2410	5	1040	3000	48	58	36 <sup>3/16</sup>	67 <sup>1/2</sup>	61 <sup>1/4</sup>	18 <sup>1/4</sup>	21 <sup>1/2</sup>	39 <sup>3/4</sup>	44 <sup>7/8</sup>	1 <sup>1/2</sup>	1	16 <sup>1/4</sup>	31	33 <sup>1/4</sup>	9.5	16	57 <sup>7/16</sup>	63 <sup>3/16</sup>	37 <sup>3/8</sup>	77 <sup>13/16</sup>	13 <sup>1/4</sup>
CS2412	5	1040	3500	48	58	36 <sup>3/16</sup>	79 <sup>1/2</sup>	73 <sup>3/8</sup>	18 <sup>1/4</sup>	24	51	56 <sup>1/8</sup>	1 <sup>1/2</sup>	2	17 <sup>3/4</sup>	31	33 <sup>1/4</sup>	9.5	16	68 <sup>7/16</sup>	75 <sup>1/2</sup>	43 <sup>1/4</sup>	87 <sup>9/16</sup>	13 <sup>1/4</sup>
CS2510	5	1040	3375	60	70	42 <sup>3/16</sup>	67 <sup>1/2</sup>	61 <sup>1/4</sup>	18 <sup>1/4</sup>	21 <sup>1/2</sup>	39 <sup>3/4</sup>	44 <sup>7/8</sup>	1 <sup>1/2</sup>	1	16 <sup>1/4</sup>	37	33 <sup>1/4</sup>	9.5	16	57 <sup>3/16</sup>	63 <sup>3/16</sup>	37 <sup>3/8</sup>	77 <sup>13/16</sup>	13 <sup>1/4</sup>
CS2512	5	1040	3950	60	70	42 <sup>3/16</sup>	79 <sup>1/2</sup>	73 <sup>3/8</sup>	18 <sup>1/4</sup>	23 <sup>3/4</sup>	51	56 <sup>1/8</sup>	1 <sup>1/2</sup>	2	17 <sup>3/4</sup>	37	33 <sup>1/4</sup>	9.5	16	68 <sup>7/16</sup>	75 <sup>9/16</sup>	43 <sup>1/4</sup>	87 <sup>9/16</sup>	13 <sup>1/4</sup>
CS2514	7.5	1040	4525	60	70	42 <sup>3/16</sup>	91 <sup>1/2</sup>	85 <sup>3/8</sup>	19 <sup>3/4</sup>	22 <sup>1/4</sup>	61 <sup>3/4</sup>	67 <sup>7/8</sup>	1 <sup>1/2</sup>	2	16 <sup>1/4</sup>	37	33 <sup>1/4</sup>	9.5	16	79 <sup>1/4</sup>	86 <sup>3/4</sup>	45 <sup>3/4</sup>	95 <sup>3/8</sup>	13 <sup>1/4</sup>
CS2612	7.5	1040	4925	72	82	48 <sup>3/16</sup>	79 <sup>1/2</sup>	73 <sup>3/4</sup>	19 <sup>3/4</sup>	22 <sup>1/4</sup>	50 <sup>1/2</sup>	56 <sup>3/8</sup>	2 <sup>1/2</sup>	2	16 <sup>1/4</sup>	43	33 <sup>1/4</sup>	9.5	16	67 <sup>15/16</sup>	75 <sup>1/2</sup>	41 <sup>7/8</sup>	87 <sup>5/8</sup>	13 <sup>1/4</sup>
CS2614	7.5	1040	5325	72	82	48 <sup>3/16</sup>	91 <sup>1/2</sup>	85 <sup>3/8</sup>	19 <sup>3/4</sup>	22 <sup>1/4</sup>	61 <sup>3/4</sup>	67 <sup>7/8</sup>	2 <sup>1/2</sup>	2	16 <sup>1/4</sup>	43	33 <sup>1/4</sup>	9.5	16	79 <sup>1/4</sup>	86 <sup>3/4</sup>	45 <sup>3/4</sup>	95 <sup>3/8</sup>	13 <sup>1/4</sup>
CS2616	7.5	1040	6225	72	83	48 <sup>3/16</sup>	103 <sup>1/2</sup>	97 <sup>3/8</sup>	19 <sup>3/4</sup>	24 <sup>3/4</sup>	73	79 <sup>3/16</sup>	2 <sup>1/2</sup>	2	18 <sup>3/4</sup>	43	33 <sup>1/4</sup>	9.5	16	90 <sup>1/2</sup>	98 <sup>1/2</sup>	52 <sup>3/4</sup>	106 <sup>13/16</sup>	13 <sup>1/4</sup>

## Model CS three-deck

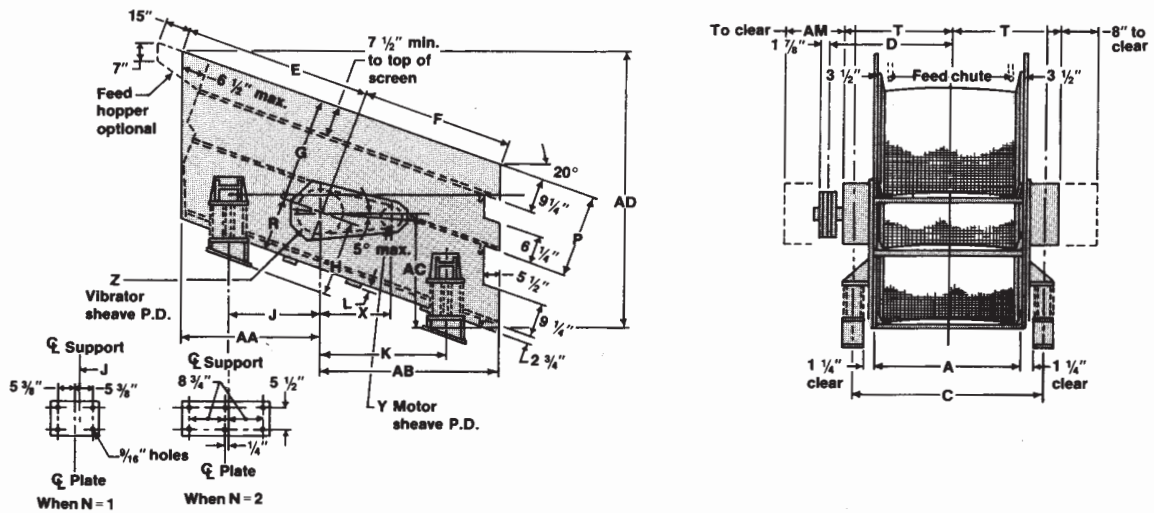

Dimensions in inches

Screen Size	HP	RPM	Vib wt. lbs.	A	C	D	E	F	G	H	J	K	L	N	p	R	T	X	Y	Z	AA	AB	AC	AD	AM
CS348	5	1040	3350	48	58	36 <sup>3/16</sup>	60 <sup>1/4</sup>	45 <sup>1/4</sup>	29 <sup>1/2</sup>	21	28 <sup>7/16</sup>	35 <sup>3/16</sup>	1 <sup>1/2</sup>	1	20 <sup>1/2</sup>	16 <sup>1/4</sup>	31	33 <sup>1/4</sup>	9.5	16	46 <sup>1/2</sup>	52 <sup>3/8</sup>	33 <sup>1/2</sup>	81 <sup>7/8</sup>	13 <sup>1/4</sup>
CS3410	5	1040	3900	48	58	36 <sup>3/16</sup>	72 <sup>1/4</sup>	57 <sup>1/8</sup>	29 <sup>1/2</sup>	21 <sup>1/2</sup>	39 <sup>3/4</sup>	44 <sup>7/8</sup>	1 <sup>1/2</sup>	1	20 <sup>1/2</sup>	16 <sup>1/4</sup>	31	33 <sup>1/4</sup>	9.5	16	57 <sup>3/4</sup>	64 <sup>1/4</sup>	37 <sup>7/16</sup>	90	13 <sup>1/4</sup>
CS3412	7.5	1040	4750	48	58	36 <sup>3/16</sup>	84 <sup>1/2</sup>	68 <sup>3/4</sup>	31 <sup>3/4</sup>	22 <sup>1/4</sup>	50 <sup>1/2</sup>	56 <sup>3/8</sup>	1 <sup>1/2</sup>	2	21 <sup>1/4</sup>	16 <sup>1/4</sup>	31	33 <sup>1/4</sup>	9.5	16	68 <sup>1/2</sup>	75 <sup>1/2</sup>	41 <sup>7/8</sup>	100 <sup>3/8</sup>	13 <sup>1/4</sup>
CS3510	7.5	1040	4425	60	70	42 <sup>3/16</sup>	72 <sup>1/4</sup>	57 <sup>1/8</sup>	29 <sup>1/2</sup>	21 <sup>1/2</sup>	39 <sup>3/4</sup>	44 <sup>7/8</sup>	1 <sup>1/2</sup>	1	20 <sup>1/2</sup>	16 <sup>1/4</sup>	37	33 <sup>1/4</sup>	9.5	16	57 <sup>3/4</sup>	64 <sup>1/4</sup>	37 <sup>7/16</sup>	90	13 <sup>1/4</sup>
CS3512	7.5	1040	5450	60	70	42 <sup>3/16</sup>	84 <sup>1/2</sup>	68 <sup>3/4</sup>	31 <sup>3/4</sup>	22 <sup>1/4</sup>	50 <sup>1/2</sup>	56 <sup>3/8</sup>	1 <sup>1/2</sup>	2	21 <sup>1/4</sup>	16 <sup>1/4</sup>	37	33 <sup>1/4</sup>	9.5	16	68 <sup>1/2</sup>	75 <sup>1/2</sup>	41 <sup>7/8</sup>	100 <sup>3/8</sup>	13 <sup>1/4</sup>
CS3514	7.5	1040	5925	60	70	42 <sup>3/16</sup>	96 <sup>1/2</sup>	80 <sup>3/4</sup>	31 <sup>3/4</sup>	22 <sup>1/4</sup>	61 <sup>3/4</sup>	67 <sup>7/8</sup>	1 <sup>1/2</sup>	2	21 <sup>1/4</sup>	16 <sup>1/4</sup>	37	33 <sup>1/4</sup>	9.5	16	79 <sup>13/16</sup>	86 <sup>3/4</sup>	45 <sup>15/16</sup>	108 <sup>13/16</sup>	13 <sup>1/4</sup>
CS3612	7.5	1040	6400	72	82	48 <sup>3/16</sup>	84 <sup>1/2</sup>	68 <sup>3/4</sup>	31 <sup>3/4</sup>	22 <sup>1/4</sup>	50 <sup>1/2</sup>	56 <sup>3/8</sup>	2 <sup>1/2</sup>	2	21 <sup>1/4</sup>	16 <sup>1/4</sup>	43	33 <sup>1/4</sup>	9.5	16	68 <sup>1/2</sup>	75 <sup>1/2</sup>	41 <sup>7/8</sup>	100 <sup>3/8</sup>	13 <sup>1/4</sup>
CS3614	10	1040	6925	72	82	48 <sup>3/16</sup>	96 <sup>1/2</sup>	80 <sup>3/4</sup>	31 <sup>3/4</sup>	22 <sup>1/4</sup>	61 <sup>3/4</sup>	67 <sup>7/8</sup>	2 <sup>1/2</sup>	2	21 <sup>1/4</sup>	16 <sup>1/4</sup>	43	33 <sup>1/4</sup>	9.5	16	79 <sup>13/16</sup>	86 <sup>3/4</sup>	45 <sup>15/16</sup>	108 <sup>13/16</sup>	13 <sup>1/4</sup>
CS3616	15	920	8800	72	82	54 <sup>3/4</sup>	108 <sup>1/2</sup>	92 <sup>3/4</sup>	33	23 <sup>1/2</sup>	72 <sup>3/4</sup>	79 <sup>3/8</sup>	2 <sup>1/2</sup>	2	21 <sup>1/4</sup>	17 <sup>1/2</sup>	46 <sup>3/16</sup>	33 <sup>1/4</sup>	10.5	20	90 <sup>11/16</sup>	98 <sup>1/2</sup>	51 <sup>7/16</sup>	119 <sup>3/8</sup>	21

▲ Number of springs per bracket.

NOTE: All above sizes are available in grease or oil lubrication.

Allow 2" vertical and 1-1/2" horizontal clearance unless otherwise shown. Have dimensions certified for installation purposes.

# Model CH Vibrating Screen

**Extra-heavy duty construction for high tonnage sizing and scalping of large lump size materials in aggregate, mining and coke industries.**

The **Model CH** Vibrating Screen efficiently sizes and scalps medium-to-large size materials. Its extra-heavy duty construction and high capacity have led to broad acceptance in a variety of aggregate, mining and coal industries.

The CH Vibrating Screen may be floor mounted or suspension mounted; however, floor-mounted models are advised when handling large lumps or heavy materials. A spring-loaded snubbing device is furnished as standard equipment with floor-mounted units to prevent excessive resonant motion during starting and stopping.

The improved CH vibrator design utilizes two rugged, self-contained double roll bearing assemblies. Each double row, self-aligning spherical roller bearing is cartridge mounted and sealed from abrasive and corrosive materials. Bearings receive direct oil bath lubrication from housing reservoir. An optional grease lubrication system can be provided if preferred. The improved design of the vibrator unbalanced weights permits faster minor stroke adjustment. Vibrator weight guards are furnished as standard equipment.

The CH Vibrating Screen is available in one, two or three-deck models with a variety of screening surfaces including perforated plate decks, screen cloth and grizzly bar decks. Accessory equipment includes washing troughs or repulping decks, bouncing ball decks, electrically heated screen cloths and total dust enclosures.



**Model CH**

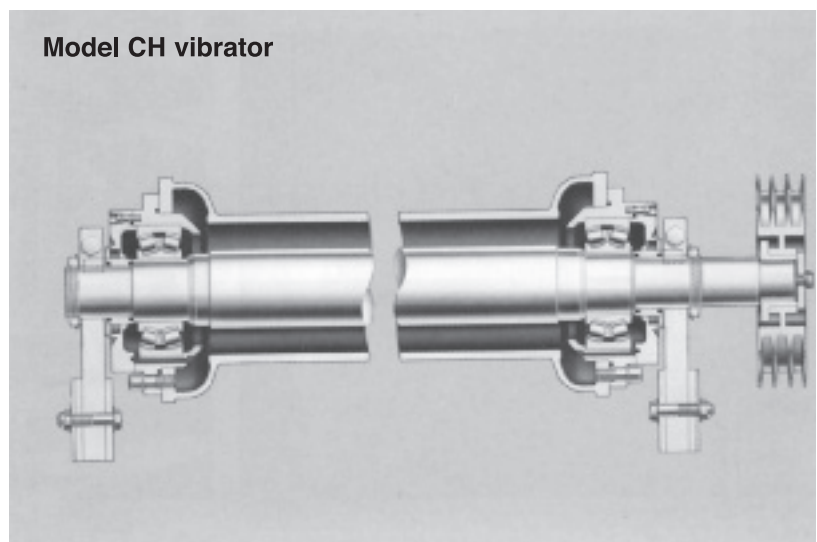

**Model CH vibrator**

# Model CH Vibrating Screen

## Model CH one-deck

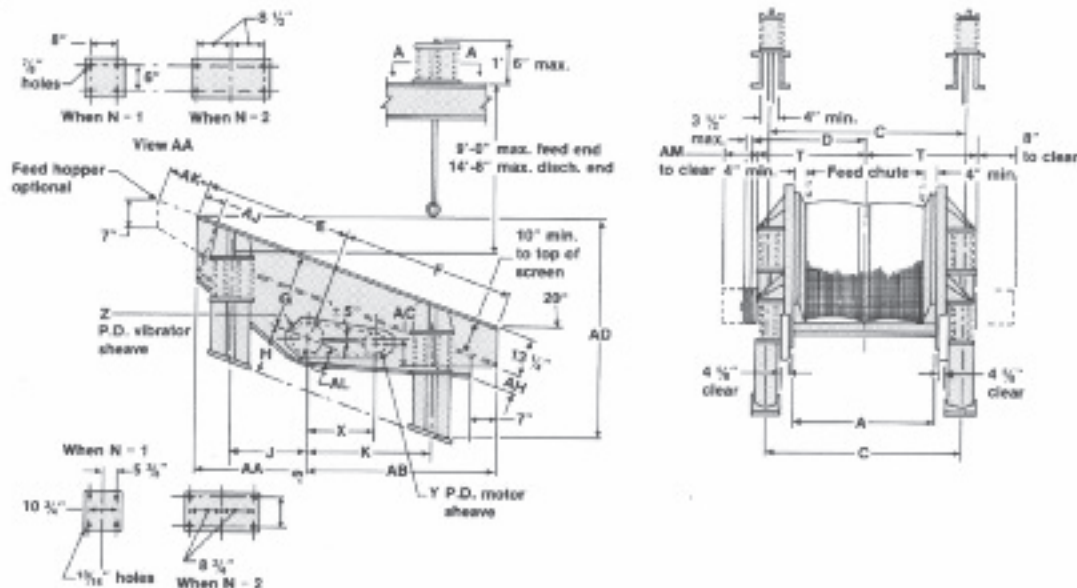

Dimensions in inches

Screen Size	HP	RPM	Vib wt. lbs.	A	C	D	E	F	G	H	J	K	N ▲	T	X	Y	Z	AA	AB	AC	AD	AH	AJ	AK	AL	AM
CH1412	5	1040	3650	48	66	36 1/4	81	75	28 1/2	15	51 1/4	61 1/2	1	31 1/16	33 1/4	9.5	16	66 3/8	80 1/8	13 3/16	92 7/8	7 3/4	9	15	14	13 1/4
CH1414	5	1040	4125	48	66	36 1/4	89	91	28 1/2	16 1/2	58 3/4	76 3/4	2	31 1/16	33 3/4	9.5	16	73 1/8	95 1/8	18 11/16	102 1/2	7 3/4	9	15	15 1/2	13 1/4
CH1510	5	1040	3700	60	78	42 1/4	65	67	28 1/2	15	36 1/4	54	1	37 7/16	33 3/4	9.5	16	51 1/4	72 3/4	10 1/4	84 1/4	7 3/4	9	15	14	13 1/4
CH1512	7.5	1040	4275	60	78	42 1/4	81	75	28 1/2	16 1/2	51 1/4	61 1/2	2	37 7/16	33 3/4	9.5	16	66 3/8	80 1/8	13 3/16	94 1/4	7 3/4	9	15	15 1/2	13 1/4
CH1514	7.5	1040	4625	60	78	42 1/4	89	91	28 1/2	16 1/2	58 3/4	76 3/4	2	37 7/16	33 3/4	9.5	16	73 1/8	95 1/8	18 11/16	102 1/2	7 3/4	9	15	15 1/2	13 1/4
CH1516	7.5	1040	5250	60	78	42 1/4	105	99	28 1/2	16 1/2	73 3/4	84 1/4	2	37 7/16	33 3/4	9.5	16	88 3/8	102 3/8	21 7/16	110 3/4	7 3/4	9	15	15 1/2	13 1/4
CH1612	7.5	1040	4550	72	90	48 1/4	81	75	28 1/2	16 1/2	51 1/4	61 1/2	2	43 7/16	33 3/4	9.5	16	66 3/8	80 1/8	13 3/16	94 1/4	7 3/4	9	15	15 1/2	13 1/4
CH1614	7.5	1040	4950	72	90	48 1/4	89	91	28 1/2	16 1/2	58 3/4	76 3/4	2	43 7/16	33 3/4	9.5	16	73 1/8	95 1/8	18 11/16	102 1/2	7 3/4	9	15	15 1/2	13 1/4
CH1616	7.5	1040	5600	72	90	48 1/4	105	99	28 1/2	16 1/2	73 3/4	84 1/4	2	43 7/16	33 3/4	9.5	16	88 3/8	102 3/8	21 7/16	110 3/4	7 3/4	9	15	15 1/2	13 1/4
CH1618	10	920	6400	72	90	51 11/16	113	115	29 1/2	17 1/2	81 1/4	99 3/4	2	44 13/16	33 3/4	10.5	20	95 1/8	118 1/8	25 1/16	121 1/4	7 3/4	9	15	16 1/2	16
CH1620	15	920	6875	72	90	51 11/16	129	123	29 1/2	17 1/2	96 3/4	106 7/8	2	44 13/16	33 3/4	10.5	20	111 1/8	125 3/8	28 7/16	129 1/2	7 3/4	9	15	16 1/2	16
CH1716	15	920	9000	84	102	57 11/16	107	99	31 1/2	21 1/2	73 3/4	84 3/4	2	50 11/16	33 3/4	10.5	20	89 3/8	103 3/8	18 11/16	120	10 1/4	11	16	20 1/2	16
CH1718	15	920	9400	84	102	57 11/16	115	115	31 1/2	17 1/2	81 1/4	99 3/4	2	50 11/16	33 3/4	10.5	20	97 3/8	118 3/8	23 13/16	123 3/4	10 1/4	11	16	16 1/2	16
CH1720	20	825	10900	84	102	60 3/4	131	123	32 1/2	22 1/2	95 3/4	107 3/4	2	51 7/16	33 3/4	9.5	20	111 1/8	126 3/8	25 11/16	138 1/2	14 1/4	11	16	21 1/2	21
CH1816	15	920	9550	96	114	63 11/16	107	99	31 1/2	21 1/2	73 3/4	84 3/4	2	56 11/16	33 3/4	10.5	20	89 3/8	103 3/8	18 11/16	120	10 1/4	11	16	20 1/2	16
CH1818	20	825	10475	96	114	66 3/4	115	115	32 1/2	18 1/2	80 3/4	99 3/4	2	57 7/16	33 3/4	9.5	20	96 3/8	119 3/8	22 3/16	126	10 1/4	11	16	17 1/2	21
CH1820	25	825	11500	96	114	66 3/4	131	123	32 1/2	22 1/2	95 3/4	107 3/4	2	57 7/16	33 3/4	9.5	20	111 1/8	126 3/8	25 11/16	138 1/2	14 1/4	11	16	21 1/2	21

▲ Number of springs per bracket.

NOTE: All above sizes are available in grease or oil lubrication.

Allow 2" vertical and 1-1/2" horizontal clearance unless otherwise shown.

Have dimensions certified for installation purposes.



Link-Belt® Model CH two-deck vibrating , 6" wide x 20' long handling rock at 200 TPH.

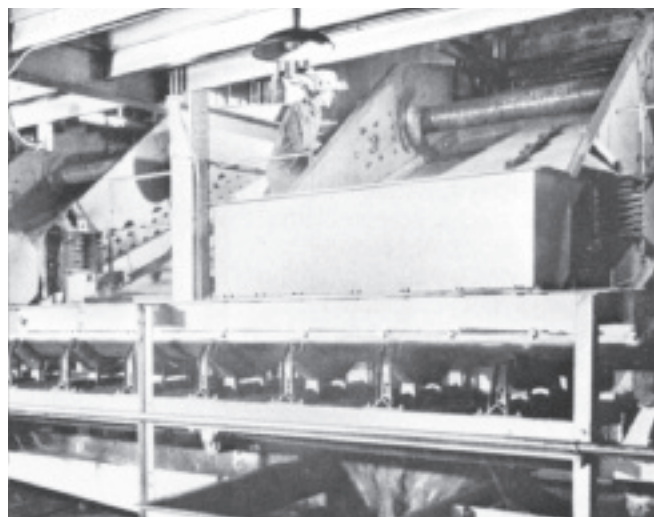

Four Link-Belt® Model Ch one-deck vibrating screens size raw coal at plus or minus 3/8". Undersize is chuted to classifiers and oversize to a belt conveyor.

### Model CH two-deck

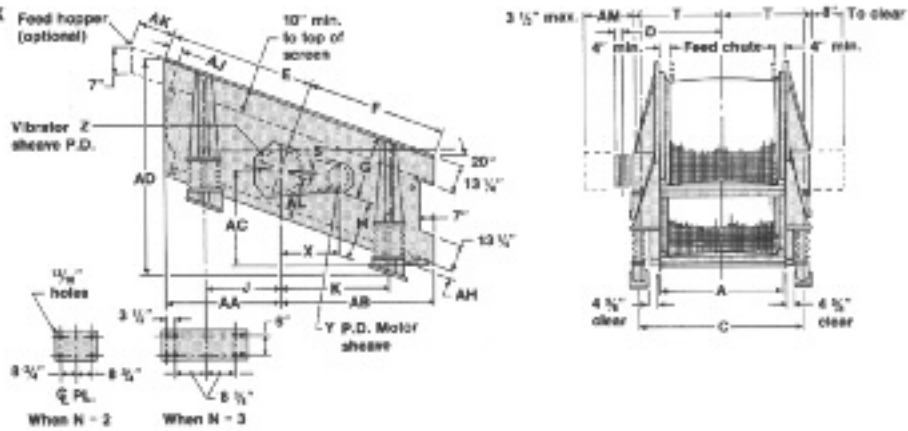

Dime

Screen Size	HP	RPM	Vib wt. lbs.	A	C	D	E	F	G	H	J	K	N	T	X	Y	Z	AA	AB	AC	AD	AH	AJ	AK	AL	AM
CH2410	7.5	1040	5325	48	66	36 1/4	65	67	28 1/2	26	36 1/4	54 1/8	2	31 7/16	33 1/4	9.5	16	51 3/8	72 3/8	45 13/16	96 1/4	6 3/4	9	15	25	13 1/4
CH2412	7.5	1040	5950	48	66	36 1/4	81	75	28 1/2	26	51 1/8	61 3/8	2	31 7/16	33 1/4	9.5	16	66 3/8	80 1/4	48 1/16	104 1/2	6 3/4	9	15	25	13 1/4
CH2414	15	920	7250	48	66	39 1/16	89	91	29 1/2	26	58 5/8	76 1/8	2	32 13/16	33 3/4	10.5	20	73 3/8	95 3/8	54 1/16	112 1/2	6 3/4	9	15	25	16
CH2510	7.5	1040	6125	60	78	42 1/4	65	67	28 1/2	26	36 1/8	54 1/8	2	37 1/16	33 1/4	9.5	16	51 3/8	72 3/8	45 1/16	96 1/4	6 3/4	9	15	25	13 1/4
CH2512	15	920	7350	60	78	45 1/16	81	75	29 1/2	25	50 3/4	62	2	38 13/16	33 3/4	10.5	20	66	80 3/8	47 1/4	104 1/2	6 3/4	9	15	24	16
CH2514	15	920	8200	60	78	45 1/16	89	91	29 1/2	26	58 5/8	76 3/8	2	38 13/16	33 3/4	10.5	20	73 3/8	95 3/8	54 3/16	112 1/2	6 3/4	9	15	25	16
CH2516	15	920	9050	60	78	45 1/16	105	99	29 1/2	26	73 3/8	84 3/8	2	38 13/16	33 3/4	10.5	20	88 3/8	103 1/8	56 1/16	121 3/4	6 3/4	9	15	25	16
CH2612	15	920	7700	72	90	51 1/16	81	75	29 1/2	26	50 5/8	61 1/8	2	44 13/16	33 3/4	10.5	20	65 1/8	80 3/8	48 3/16	105 1/2	6 3/4	9	15	25	16
CH2614	15	920	8775	72	90	51 1/16	89	91	29 1/2	26	58 5/8	76 3/8	2	44 13/16	33 3/4	10.5	20	73 3/8	95 3/8	54 3/16	112 1/2	6 3/4	9	15	25	16
CH2616	20	825	10325	72	90	54 3/4	105	99	30 1/2	25	73	84 3/4	2	45 7/16	33 3/4	9.5	20	88	103 1/2	56	121 3/4	6 3/4	9	15	24	21
CH2618	25	825	11050	72	90	54 3/16	113	115	30 1/2	26 1/2	80 3/8	99 7/8	3	47 13/16	33 3/4	9.5	20	95 3/8	118 3/8	63 3/16	132	6 3/4	9	15	25 1/2	21
CH2620	25	825	11925	72	90	54 3/16	129	123	30 1/2	26 1/2	95 3/8	107 3/8	3	47 13/16	33 3/4	9.5	20	110 3/8	125 3/8	66 3/16	139 1/4	6 3/4	9	15	25 1/2	21
CH2716	25	825	13850	84	102	60 3/4	107	99	32 1/2	28 1/2	72 3/8	84 7/8	2	51 7/16	33 3/4	9.5	20	89 3/8	104 1/8	57 3/16	128 1/2	8 3/4	11	16	27 1/2	21
□CH2718	40	725	15400	84	102	60 1/16	115	115	33 1/2	27 1/2	80 1/4	100 1/4	3	54 13/16	33 3/4	10.0	24	96 1/2	119 1/2	62 7/16	136 3/4	8 3/4	11	16	26 1/2	21
□CH2720	40	725	16925	84	102	60 1/16	131	123	33 1/2	31 1/2	94 7/8	108 1/8	3	54 13/16	33 3/4	10.0	24	111 3/4	127	69 3/16	149	8 3/4	11	16	30 1/2	21
□CH2816	40	725	15425	96	114	66 1/16	107	99	33 1/2	27 1/2	72 1/2	85 1/4	3	60 1/16	33 3/4	10.0	24	89	104 1/2	57	128 1/2	8 3/4	11	16	26 1/2	21
□CH2818	40	725	16500	96	114	66 1/16	115	115	33 1/2	31 1/4	79 1/8	100 3/8	3	60 1/16	33 3/4	10.0	24	96 3/8	119 3/8	66 3/16	140 3/4	8 3/4	11	16	30 1/4	21
□CH2820	50	650	18825	96	114	67 3/8	131	123	34 1/2	30 1/4	94 1/2	108 1/2	3	60 7/16	34 1/2	9.0	24	111 3/8	127 3/8	68 1/4	149	8 3/4	11	16	29 1/4	22

### Model CH three-deck

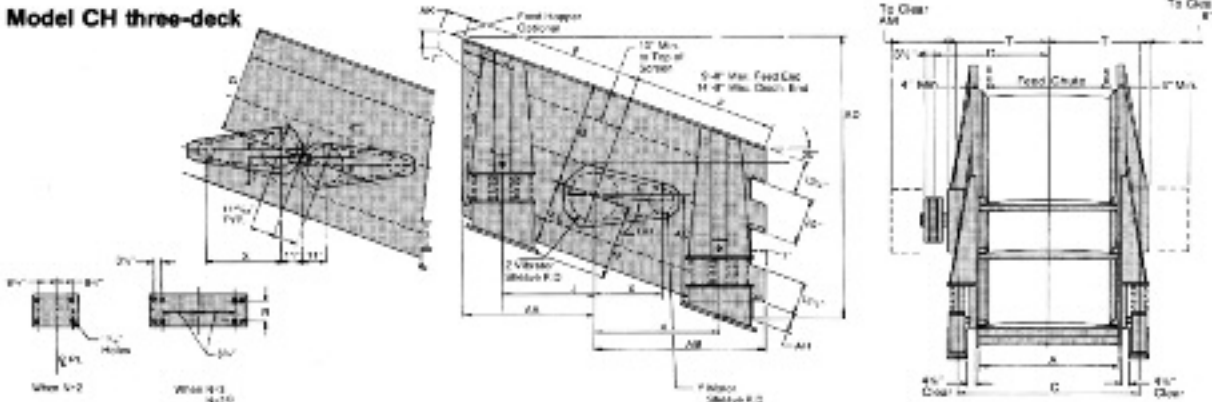

Dimensions in inches

Screen Size	HP	RPM	Vib wt. lbs.	A	C	D	E	F	G	H	J	K	N	R	T	X	Y	Z	AA	AB	AC	AD	AH	AJ	AK	AL	AM
CH3410	15	920	7600	48	66	39 1/16	72 1/4	59 3/4	49 1/2	25	36	61 1/8	2	6	32 13/16	33 1/4	10.5	20	51	73	45	117 1/2	6 3/4	9	15	24	16
CH3412	15	920	8600	48	66	39 1/16	88 1/4	67 3/4	49 1/2	26	50 7/8	61 1/8	2	6	32 13/16	33 1/4	10.5	20	66 1/8	80 3/8	48 13/16	127	6 3/4	9	15	25	16
CH3414	20	825	10400	48	66	42 3/4	96 1/4	83 3/4	50 1/2	26 1/2	58 1/8	77 1/8	2	6	33 7/16	33 1/4	9.9	20	72 7/8	95 7/8	54 15/16	136 1/2	6 3/4	9	15	25 1/2	21
CH3510	15	920	8800	60	78	45 1/16	72 1/4	59 3/4	49 1/2	25	36	54 1/4	2	6	38 13/16	33 3/4	10.5	20	51	73	45	117 1/2	6 3/4	9	15	24	16
CH3512	20	825	10550	60	78	48 3/4	88 1/4	67 3/4	50 1/2	25	50 1/2	62 1/4	2	6	39 7/16	33 3/4	9.5	20	65 3/4	80 3/4	48	127	6 3/4	9	15	24	21
CH3514	25	825	11825	60	78	48 3/4	96 1/4	83 3/4	50 1/2	26 1/2	58 1/2	77 1/8	2	6	39 7/16	33 3/4	9.5	20	72 7/8	95 7/8	54 15/16	136 1/2	6 3/4	9	15	25 1/2	21
□CH3516	30	725	13325	60	78	48 1/16	112 1/4	91 3/4	51 1/2	25 1/2	72 3/4	85	3	6	42 13/16	33 3/4	10.0	24	87 3/4	103 3/4	56 3/4	145	6 3/4	9	15	24 1/2	21
CH3612	25	825	11275	72	90	54 3/4	88 1/4	67 3/4	50 1/2	25	50 1/2	62 1/4	2	6	45 7/16	33 3/4	9.5	20	65 3/4	80 3/4	48	127	6 3/4	9	15	24	21
□CH3614	30	725	13400	72	90	54 1/16	96 1/4	83 3/4	51 1/2	25 1/2	57 3/4	77 1/2	3	6	48 13/16	33 3/4	10.0	24	72 1/2	96 1/4	54	136 1/2	6 3/4	9	15	24 1/2	21
□CH3616	30	725	14225	72	90	54 1/16	112 1/4	91 3/4	51 1/2	25 1/2	72 3/4	85	3	6	48 13/16	33 3/4	10.0	24	87 3/4	103 3/4	56 3/4	145	6 3/4	9	15	24 1/2	21
□CH3618	40	725	15850	72	90	54 1/16	120 1/4	107 3/4	51 1/2	29 1/4	80 3/8	100 3/8	3	6	48 13/16	33 3/4	10.0	24	95 3/16	118 3/16	68 3/16	157 1/4	6 3/4	9	15	28 1/4	21
□CH3620	40	725	17225	72	90	54 1/16	136 1/4	115 3/4	51 1/2	29 1/4	95 3/8	107 3/16	2	8	48 13/16	33 3/4	10.0	24	110 3/16	125 3/16	68 3/16	165 3/8	6 3/4	9	15	28 1/4	22
□CH3716	50	650	20750	84	104	61 3/8	114 1/4	91 3/4	54 1/2	30 1/4	71 3/4	85 7/8	2	8	55 7/16	34 1/2	9.0	24	88 3/4	104 3/4	60	157 3/8	8 3/4	11	16	29 1/4	22
□CH3718	50	650	22100	84	104	61 3/8	122 1/4	107 3/4	54 1/2	30 1/4	79 1/2	101	2	8	55 7/16	34 1/2	9.0	24	96 1/8	119 3/8	65 1/2	162	8 3/4	11	16	29 1/4	22
★CH3720	25	825	25400	84	104	60 3/4	138 1/4	115 3/4	54 1/2	30 1/4	94 1/2	108 1/2	2	8	55 7/16	33 3/4	9.5	20	111 3/8	127 3/8	68 3/16	170 3/16	8 3/4	11	16	29 1/4	21
□CH3816	50	650	22000	96	116	67 3/4	114 1/4	91 3/4	54 1/2	30 1/4	71 3/4	85 7/8	2	8	60 1/4	34 1/2	9.0	24	88 3/4	104 3/4	60	153 3/8	8 3/4	11	16	29 1/4	22
★CH3818	25	825	24825	96	116	66 3/4	122 1/4	107 3/4	54 1/2	30 1/4	79 1/2	101	2	8	61 1/16	33 3/4	9.5	20	96 1/8	119 3/8	65 1/2	162	8 3/4	11	16	29 1/4	21
★CH3820	25	825	26900	96	116	66 3/4	138 1/4	115 3/4	54 1/2	30 1/4	94 1/2	108 1/2	2	8	61 1/16	33 3/4	9.5	20	111 3/8	127 3/8	68 3/16	170 3/16	8 3/4	11	16	29 1/4	21

- ▲ Number of springs per bracket.
- These models available for grease lubrication only. All other models are available for grease or oil lubrication.
- ★ DUAL VIBRATORS [Use (2) 25 HP or 50 HP]

- Heavy-duty Springs
- Allow 2" vertical and 1-1/2" horizontal clearance unless otherwise shown. Have dimensions certified for installation purposes.

# Models CS and CH Dust-Tight Enclosures

All CS and CH Vibrating Screen models can be supplied with dust-tight enclosures. Each enclosure is completely isolated from vibration to maintain its structural integrity and avoid the need for flexible connections at feed and discharge points. Feed chutes and discharge chutes are furnished with flange connections for easy attachment to other chutes and conveyors. Enclosures contain easily removed, light weight sectionalized panels for servicing the screens. The enclosure is designed to give total access to tension bolts and support springs while still retaining a complete enclosure around the screen. Dust-tight enclosures are available for all CS and CH models and are available in either the trelleborg rubber or the all metal designs.

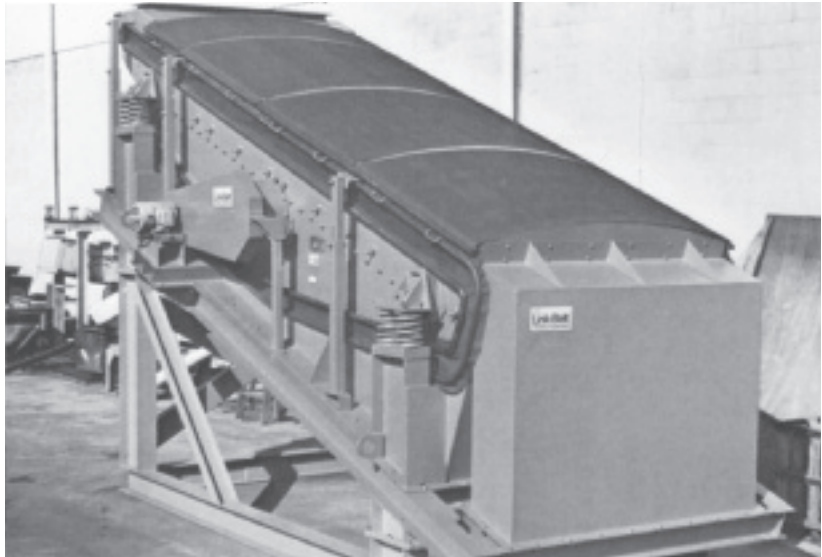

Model CS 1616 with trelleborg rubber enclosure.

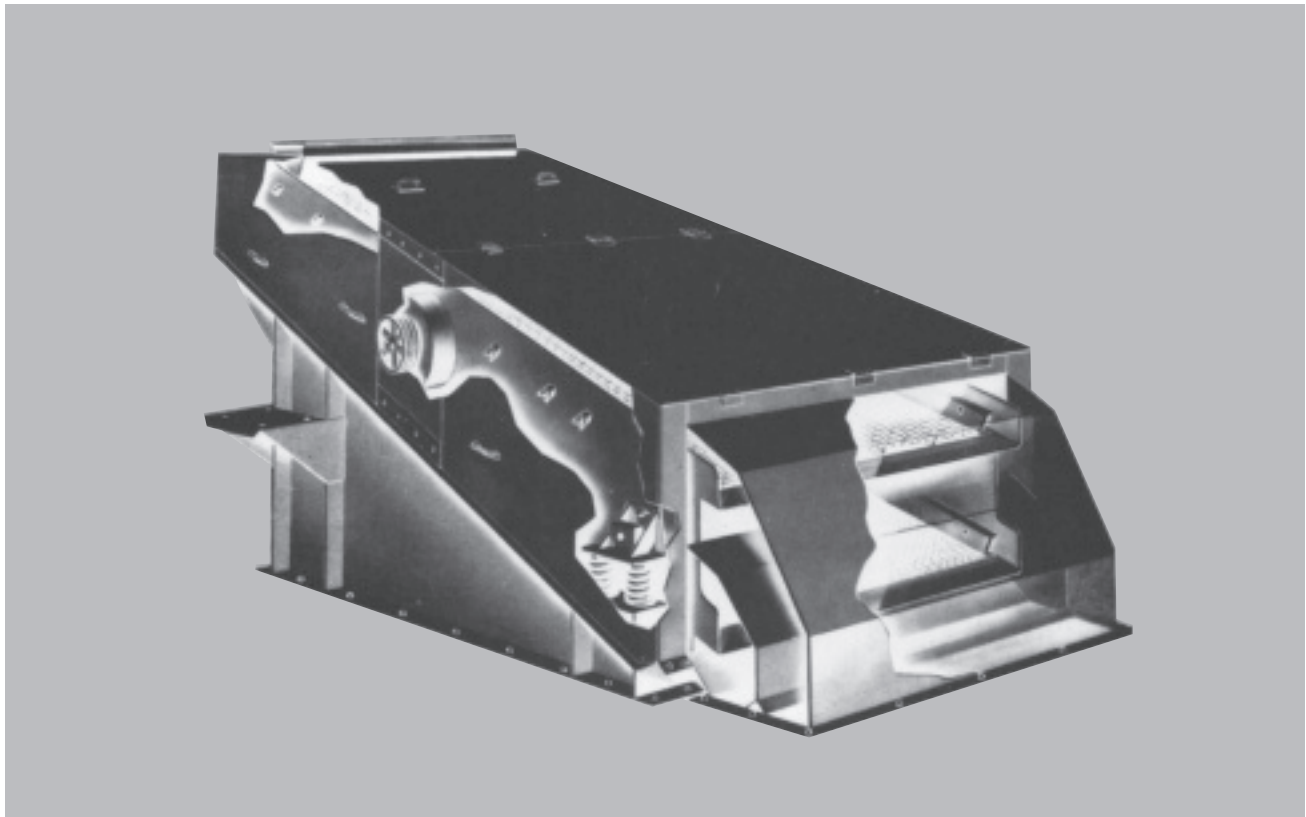

Model CS 2616 with all metal enclosure.

# Model BA Vibrating Screen

**Heavy-duty scalping unit with the rugged construction required for handling ore, rock and aggregate.**

Heavy-duty **Model BA** sizing and scalping screens are built with rugged deck construction and a powerful vibrator to provide unexcelled high-tonnage handling of ore, rocks and similar lumpy, mined materials.

Each model BA component is designed for years of dependable, low-maintenance service. Handling constant high-impact loads of dusty, corrosive or abrasive materials. Decks are built of deep section ship channels welded to H-beams. For maximum strength and freedom from distortion, the welded steel decks are stress-relieved and held in place by high-strength bolts. Large, square-end helical springs isolate vibration from the supporting foundation, yet maintain vibration of the live frame.

The BA improved vibrator design utilizes two, rugged, self-contained double roll assemblies. Each double row, self-aligning spherical roller bearing is cartridge mounted and sealed from abrasion and corrosive materials. Bearing receive direct oil bath lubrication from housing reservoir. An optional grease lubrication system can be provided if preferred. The improved design of the vibrator unbalanced weights permits faster minor stroke adjustment. Vibrator weight guards are furnished as standard equipment.

Model BA Vibrating Screens are available in one-deck and two-deck units.

**Model BA**

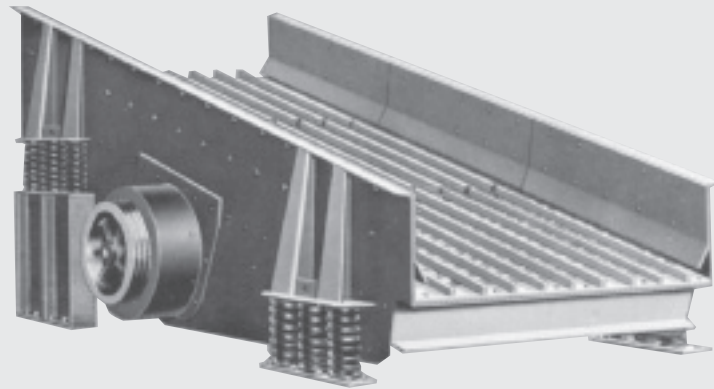

**Note: Safety guards have been removed from this photo for clarity, but are required on all operating equipment.**

**Model BA vibrator**

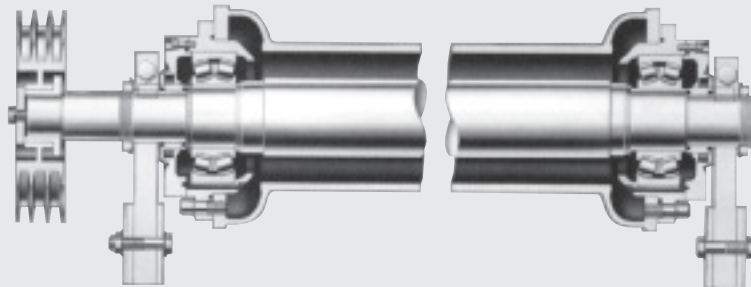

### Model BA one-deck

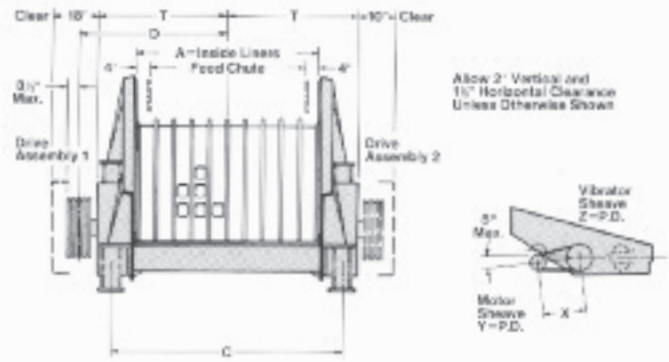
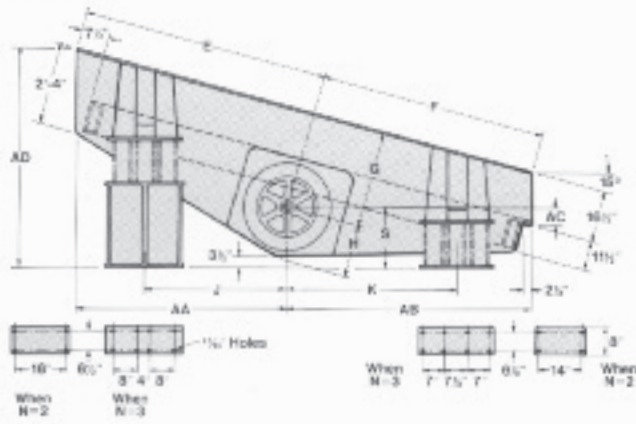

Dimensions in inches

Screen Size	Vibrating weight pounds	HP	Vibrator RPM	A	C	D	E	F	G	H	J	K	N ▲	T	S	X	Y	Z	AA	AB	AC	AD
BA1510	7000	10	875	59 1/4	78	47 1/2	65 3/4	61 1/2	34 1/2	13	34 3/8	50	2	40 1/2	21 1/2	38 1/2	8	16	54 1/2	68 1/2	0	71 3/4
BA1512	9000	15	790	59 1/4	78	48	81 3/4	69 1/2	35 1/2	15	38 3/8	54 1/4	2	42	22	38 3/8	9	20	69 3/4	76 3/8	1	77 1/2
BA1612	9900	20	790	71 1/4	90	54	81 3/4	69 1/2	35 1/2	15	38 3/8	54 1/4	3	48	22	38 3/8	9	20	69 3/4	76 3/8	1	77 1/2
BA1614	10700	20	790	71 1/2	90	54	89 3/4	85 1/2	35 1/2	15	53 7/8	62	3	48	23	38 3/8	9	20	77 3/8	91 3/4	5 1/4	80 3/4
BA1616	12800	25	730	71 1/2	90	54	105 3/4	93 1/2	36 1/2	15	69	77 3/8	3	48 1/2	23	38 3/8	10	24	92 1/2	99 3/4	6 1/4	85 7/8

▲ Number of springs per bracket

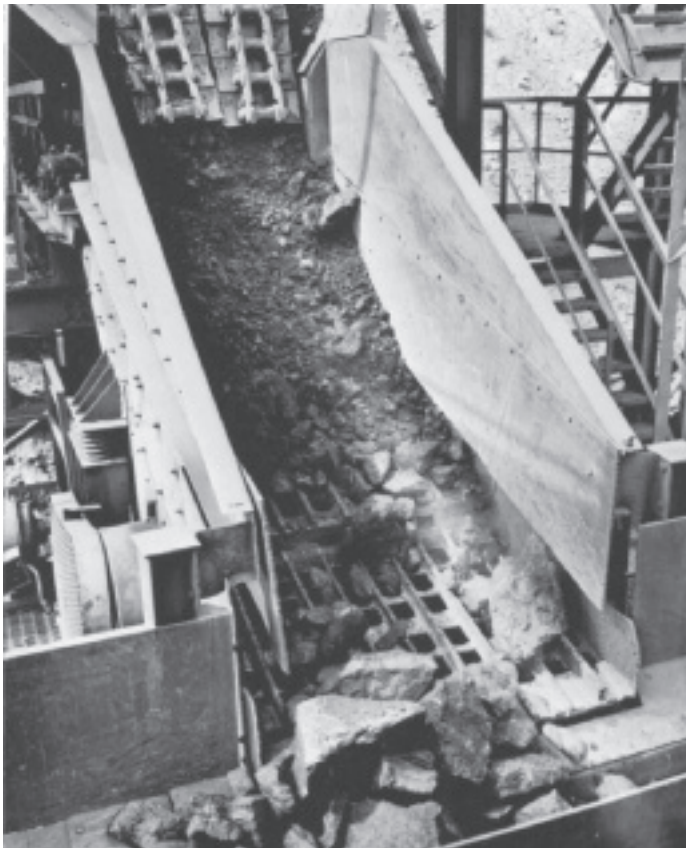

Link-Belt® Model BA heavy duty vibrating screen scalping iron ore. 4" and under passes through screen to a feeder while oversize travels over screen to crusher.



# Link-Belt® Models SS and SG Vibrating Screens

**Built to work hard, last long and keep a low profile.**

Link-Belt® Models SS and SG Vibrating Screens are available to handle your most difficult screening applications.

A broad range of Vibrating Screen types and models permits you to select the units that best meet your specific material processing needs, operating conditions and capacity requirements.

The horizontal screens described here are designed for installations with limited headroom. All models use vigorous, straightline motion to both screen and convey a wide range of materials. These units include:

- Model SS Vibrating Screens, a heavy-duty screen featuring the Synchronomatic vibrator.
- Model SG, equipped with a heavy-duty, geared vibrator, for years of trouble-free performance in washing, dewatering and sizing.

Each of these screens is furnished with a motor plugging device to reduce resonant vibration and side-sway when stopping, and will operate from 230, 460 or 550 volt, 3 phase 60 cycle a.c., as specified. All models can be supplied for floor or suspension mounting, or combined floor and suspension mounting. Model SS and SG Vibrating Screens are available as one, two or three-deck units.

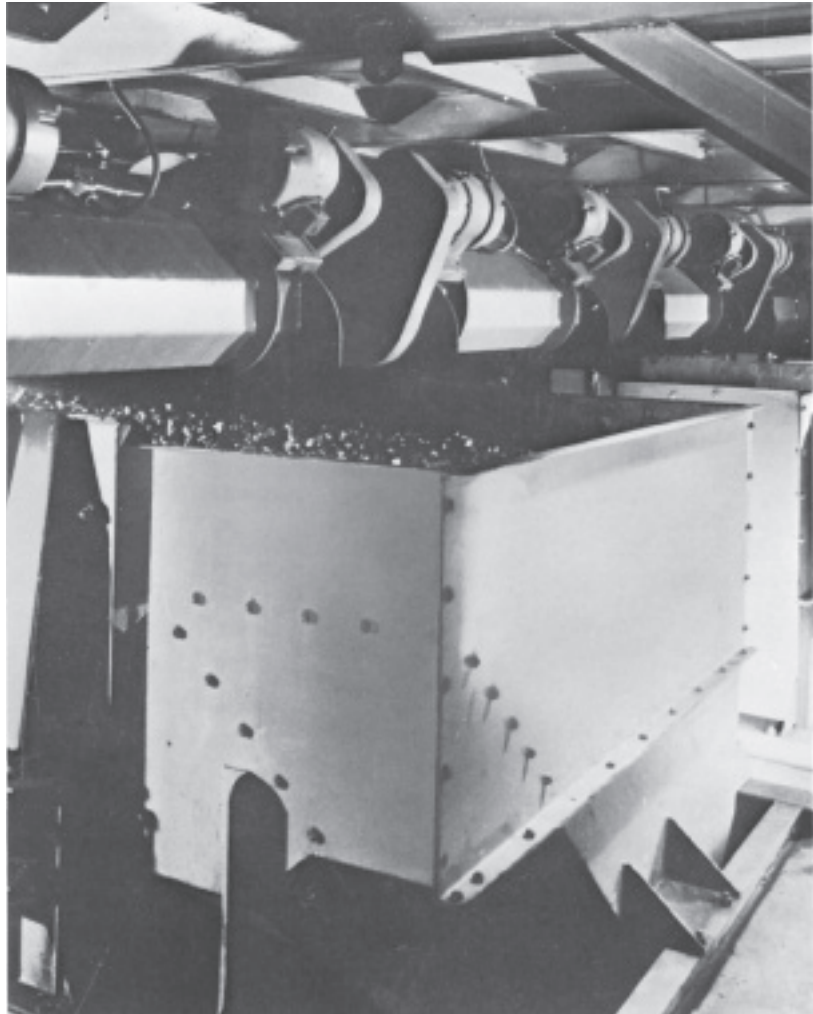

# Model SS

Model SS horizontal screens are designed for washing, dewatering and sizing coal, gravel and similar materials in facilities with limited headroom. Specifying these units for a new installation may permit a reduction in the overall building height. High-intensity straightline vibrations, produced by the unique Synchronomatic vibrator, make this unit ideal for dewatering materials where packing or squeezing are essential. This exclusive FMC vibrator design features two automatically synchronized unbalanced shafts rotating in opposite directions to produce a straightline vibrating motion. The vibration intensity can be altered by changing the amount of shaft unbalance.

Separate foot mounted motors drive each of the two unbalanced shafts. Locating these motors above the vibrator housing, they are not subjected to liquid or dust contamination. A shorter V-belt reduces whip, stretch, slip, and wear, lessens starting torque requirements, and makes full use of motor horsepower. Over-size, self-aligning, spherical roller bearings provide the additional capacity necessary to withstand the high centrifugal forces produced by the unbalanced shafts. Labyrinth bearing seals provide positive retention of lubricant and protect the bearings from abrasive dust and corrosive atmospheres. Only the bearings require lubrication since the Synchronomatic vibrator contains no gears.

Rugged describes the construction and assembly of the Model SS vibrating screen. Heavy sideplates, flanged and reinforced with angles, provide years of service. High-strength bolts are used to secure screen decks to the sideplates. Efficient distribution of vibrator loads into the sideplates is the result of a long row of high-strength bolts, properly spaced and torqued to assure endless hours of continuous service.

Screening surfaces for the Model SS screen can be furnished with many types of commercial screening media such as woven wire cloth, perforated plate, or profile wire type panels. Optional equipment for this unit includes electrically heated screen cloth, bouncing ball decks, washing troughs and dust-tight enclosures.

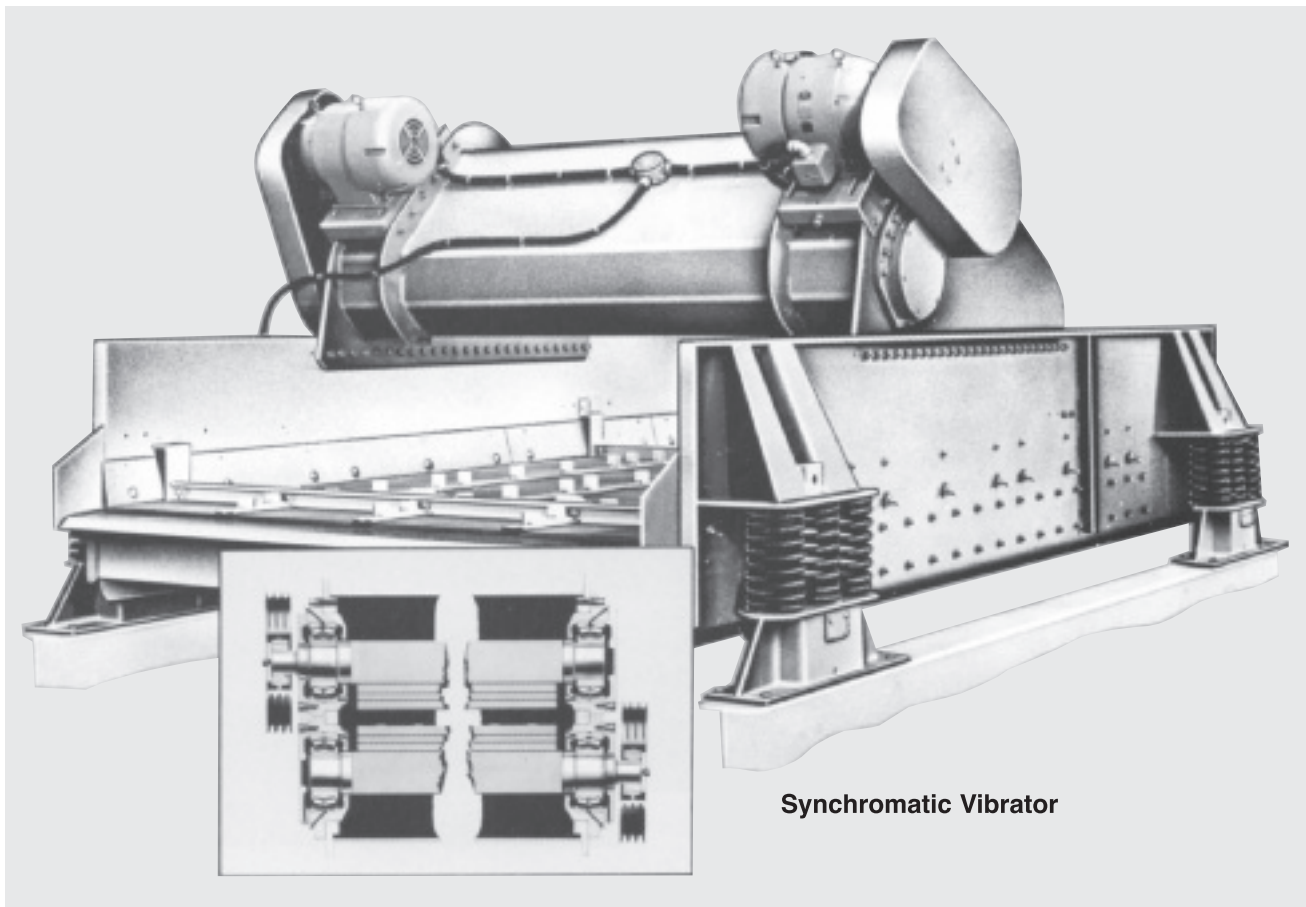

Model SG horizontal vibrating screens are used in low-headroom installations to efficiently wash, dewater and size coal, ore, rock, gravel and other materials. The unit's vibrator produces a powerful straightline motion which both screens and conveys materials. Four heavy-duty, double row, individually cartridge-mounted, self-aligning spherical roller bearings support the two eccentric shafts, which are driven through helical gears. Large, alloy steel, precision helical gears mounted on tapered

bushings, drive the vibrator's two eccentric shafts. Bearing lubrication is performed through grease channels to the center of the cartridges. Gears are self-lubricated by a deep oil reservoir. The Model SG vibrating screen features the same rugged construction described with the Model SS vibrating screen, and is available in one, two or three-deck units.

The sideplates are reinforced with heavy angles. High-strength bolts secure the screen decks to the sideplates, and proper distribution

of the vibrator loads into the sideplates assures uniform straightline motion for sizing, dewatering and washing applications. Screening surfaces available for the Model SG screen include woven wire cloth, perforated plate, wedge wire type panels, and other commercially available screening media. Optional equipment includes electrically heated screen cloth, bouncing ball decks, washing troughs and dust-tight enclosures.

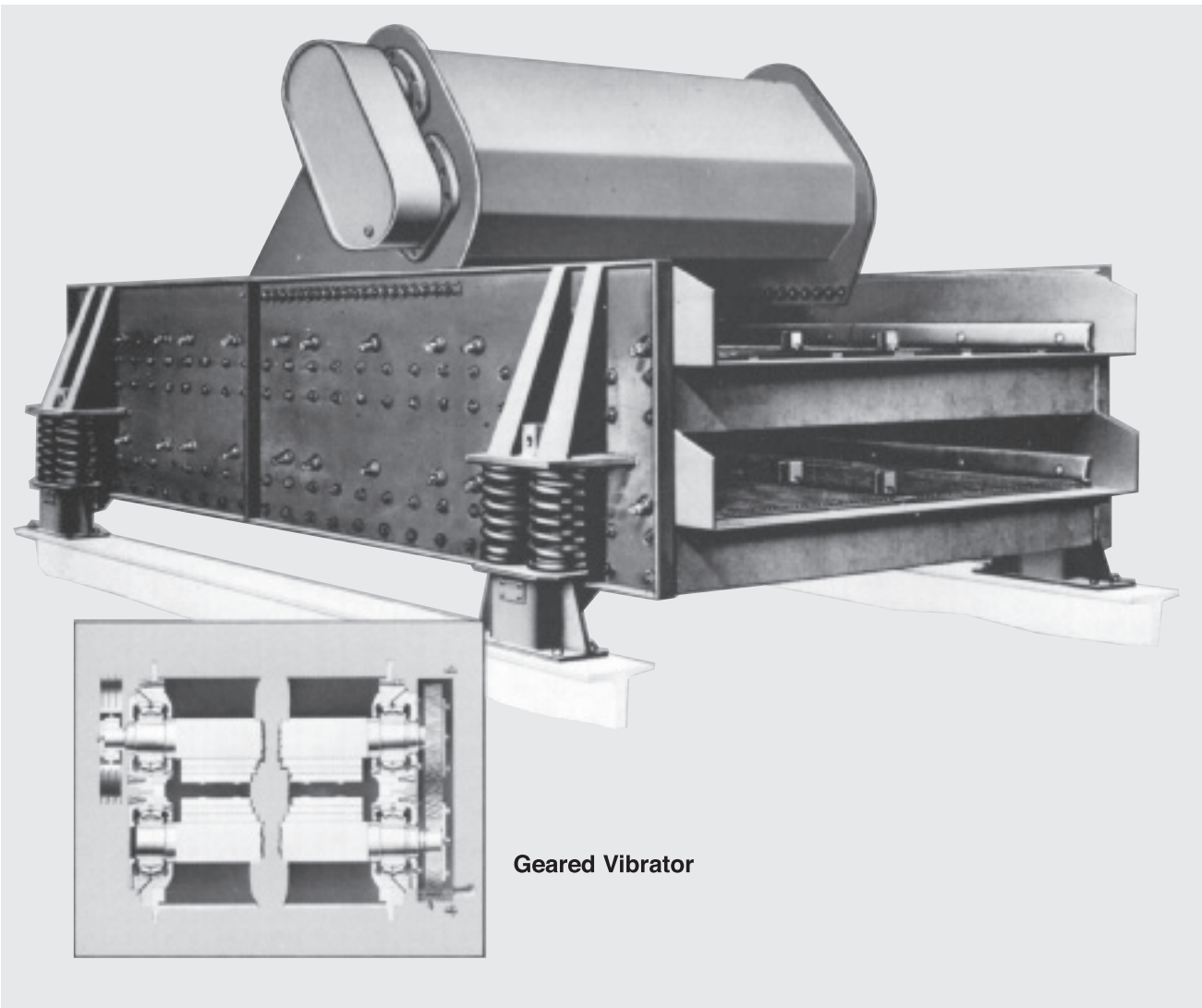

# Models SS and SG one-deck vibrating screen

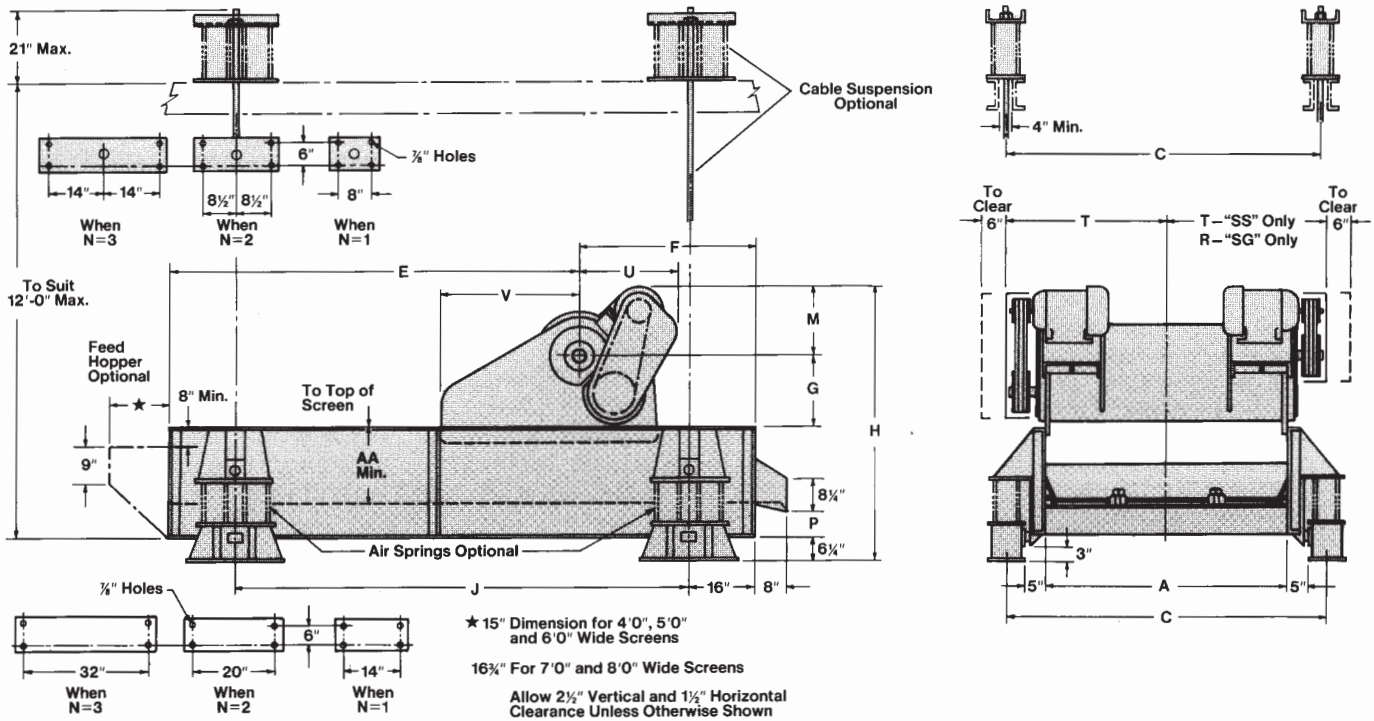

Dimensions in inches

Screen Size	Vibrating weight pounds	Type SS				Type SG				A	C	E	F	G	H	J	M	N	P	R	T	U	V	AA
		Speed RPM	Motor HP	Motor No.	Speed RPM	Motor HP	Motor No.																	
148	4100	920	3	2	920	5	1	48	66	67	29 1/2	14 1/4	63 7/8	64	15 3/8	1	6 3/4	32	31 3/8	23 5/8	28 1/2	17 1/2		
1410	4500	920	5	2	920	7 1/2	1	48	66	79	41 1/2	14 1/4	63 7/8	88	15 3/8	1	6 3/4	32	31 3/8	23 5/8	28 1/2	17 1/2		
1412	5700	920	5	2	920	7 1/2	1	48	66	92 1/2	52	16 5/8	66 7/8	112	16	1	6 3/4	32 1/4	31 7/8	25 1/2	32 7/8	17 1/2		
1414	6900	920	5	2	920	10	1	48	66	107	61 1/2	16 5/8	63 7/8	136	16	1	6 3/4	32 1/4	32 1/8	27 1/4	32 7/8	17 1/2		
1416	7450	920	7 1/2	2	920	10	1	48	66	119	73 1/2	16 5/8	68 7/8	160	18	2	6 3/4	32 1/4	32 1/8	27 1/4	32 7/8	17 1/2		
158	4500	920	5	2	920	7 1/2	1	60	78	67	29 1/2	14 1/4	63 7/8	64	15 3/8	1	6 3/4	38	37 3/8	23 5/8	28 1/2	17 1/2		
1510	5950	920	5	2	920	10	1	60	78	80 1/2	40	16 5/8	66 7/8	88	16	1	6 3/4	38 1/4	37 7/8	25 1/2	32 7/8	17 1/2		
1512	6700	920	7 1/2	2	920	10	1	60	78	92 1/2	52	16 5/8	68 7/8	112	18	1	6 3/4	38 1/4	38 1/8	27 1/4	32 7/8	17 1/2		
1514	7750	920	7 1/2	2	920	10	1	60	78	107	61 1/2	16 5/8	68 7/8	136	18	2	6 3/4	38 1/4	38 1/8	27 1/4	32 7/8	17 1/2		
1516	8550	920	7 1/2	2	920	10	1	60	78	119	73 1/2	16 5/8	68 7/8	160	18	2	6 3/4	38 1/4	38 1/8	27 1/4	32 7/8	17 1/2		
1518	10450	920	10	2	920	15	1	60	78	133 1/2	83	19 1/8	73 1/4	184	17 7/8	2	6 3/4	39 3/4	39 1/4	28 1/2	43	19 1/2		
1520	11600	920	10	2	920	15	1	60	78	147	93 1/2	19 1/8	75 1/4	208	17 7/8	2	6 3/4	39 3/4	39 1/4	28 1/2	43	21 1/2		
168	6050	920	5	2	920	7 1/2	1	72	90	68 1/2	29	16 5/8	66 7/8	64	16	1	6 3/4	44 1/4	43 7/8	25 1/2	32 7/8	18 1/2		
1610	6450	920	5	2	920	10	1	72	90	80 1/2	40	16 5/8	66 7/8	88	16	1	6 3/4	44 1/4	43 7/8	25 1/2	32 7/8	18 1/2		
1612	7200	920	5	2	920	10	1	72	90	92 1/2	52	16 5/8	66 7/8	112	16	1	6 3/4	44 1/4	43 7/8	25 1/2	32 7/8	18 1/2		
1614	8300	920	7 1/2	2	920	10	1	72	90	107	61 1/2	16 5/8	68 7/8	136	18	2	6 3/4	44 1/4	44 1/8	27 1/4	32 7/8	18 1/2		
1616	10200	920	10	2	920	15	1	72	90	120	72 1/2	19 1/8	71 1/4	160	17 7/8	2	6 3/4	45 3/4	45 1/4	28 1/2	43	18 1/2		
1618	11050	920	10	2	920	15	1	72	90	133 1/2	83	19 1/8	73 1/4	184	17 7/8	2	6 3/4	45 3/4	45 1/4	28 1/2	43	20 1/2		
1620	12300	870	10	2	920	15	1	72	90	147	93 1/2	19 1/8	75 1/4	208	17 7/8	3	6 3/4	45 3/4	45 1/4	28 1/2	43	22 1/2		
1716	14100	815	15	2	870	20	1	84	102	124	68 1/2	21 1/4	82 1/4	160	20 3/4	3	8 3/4	52 1/4	51 3/8	32 3/8	50	21 1/2		
1718	14700	815	15	2	815	20	1	84	102	135 1/2	81	21 1/4	82 1/4	184	20 3/4	3	8 3/4	52 1/4	51 3/8	32 3/8	50	21 1/2		
1720	15900	815	15	2	815	20	1	84	102	147	93 1/2	21 1/4	82 1/4	208	20 3/4	3	8 3/4	52 1/4	51 3/8	32 3/8	50	21 1/2		
1816	14900	815	15	2	815	20	1	96	114	124	68 1/2	21 1/4	82 1/4	160	20 3/4	3	8 3/4	58 1/4	57 3/8	32 3/8	50	21 1/2		
1818	15500	815	15	2	815	20	1	96	114	135 1/2	81	21 1/4	82 1/4	184	20 3/4	3	8 3/4	58 1/4	57 3/8	32 3/8	50	21 1/2		

▲ Number of springs per corner.

■ M dimension varies on Type SG - consult Syntron Material Handling.

# Models SS and SG two-deck vibrating screen

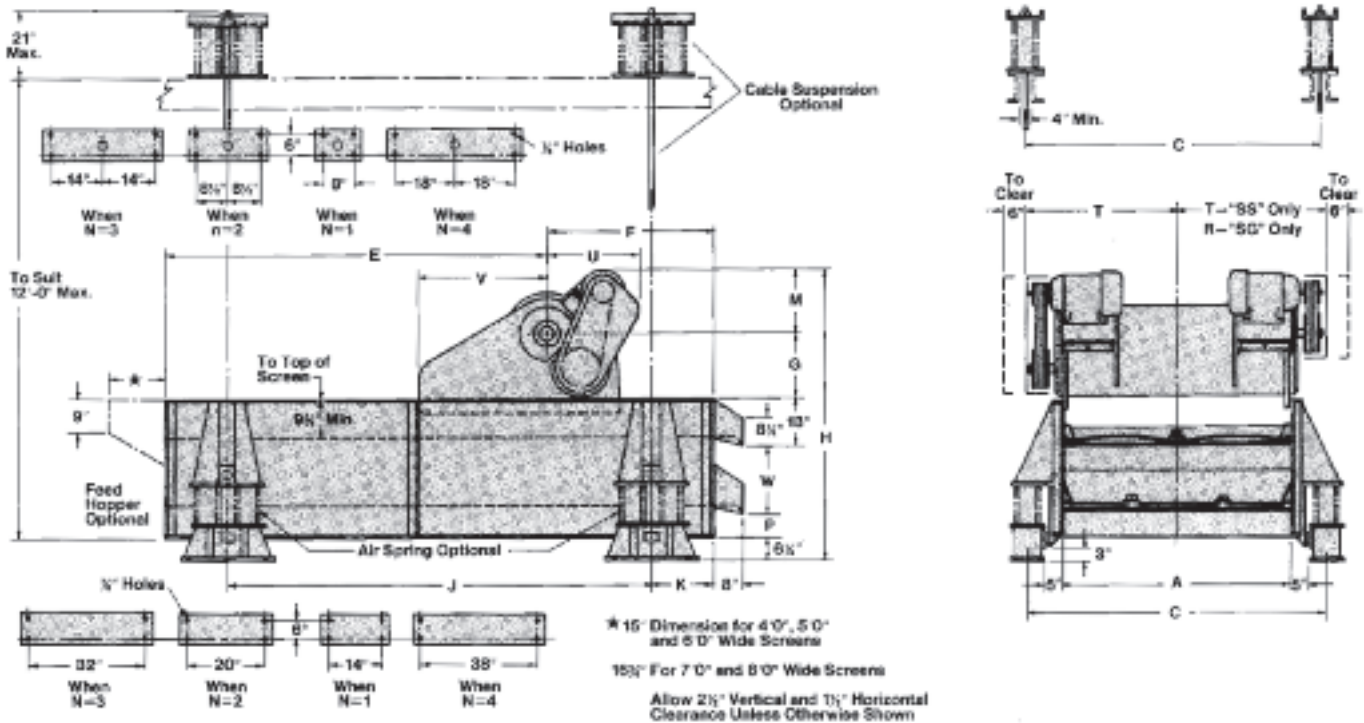

Dimensions in inches

Screen Size	Vibrating weight pounds	Type SS				Type SG♦				A	C	E	F	G	H	J	K	M■	N▲	P	R	T	U	V	AA
		Speed RPM	Motor HP	Motor No.	Speed RPM	Motor HP	Motor No.																		
248	6850	920	5	2	920	10	1	48	66	75 1/2	21	16 5/8	82 5/8	64	16	16	1	6 3/4	32 1/4	31 7/8	25 1/2	32 7/8	24		
2410	7650	920	7 1/2	2	920	10	1	48	66	89	31 1/2	16 5/8	84 5/8	88	16	18	2	6 3/4	32 1/4	32 1/8	27 1/4	32 7/8	24		
2412	8500	920	7 1/2	2	920	10	1	48	66	101	43 1/2	16 5/8	84 5/8	112	16	18	2	6 3/4	32 1/4	32 1/8	27 1/4	32 7/8	24		
2414	10900	920	10	2	920	20	1	48	66	114	54 1/2	19 1/8	87	136	16	17 7/8	2	6 3/4	33 3/4	33 1/4	28 1/2	43	24		
2416	11750	920	10	2	920	20	1	48	66	126	66 1/2	19 1/8	87	160	16	17 7/8	2	6 3/4	33 3/4	33 1/4	28 1/2	43	24		
258	7750	920	7 1/2	2	920	10	1	60	78	75 1/2	21	16 5/8	84 5/8	64	16	18	2	6 3/4	38 1/4	38 1/8	27 1/4	32 7/8	24		
2510	8550	920	7 1/2	2	920	15	1	60	78	89	31 1/2	16 5/8	84 5/8	88	16	18	2	6 3/4	38 1/4	38 1/8	27 1/4	32 7/8	24		
2512	10500	920	10	2	920	15	1	60	78	102	42 1/2	19 1/8	87	112	16	17 7/8	2	6 3/4	39 3/4	39 1/4	28 1/2	43	24		
2514	11950	920	10	2	920	20	1	60	78	114	54 1/2	19 1/8	87	136	16	17 7/8	2	6 3/4	39 3/4	39 1/4	28 1/2	43	24		
2516	12950	815	10	2	815	25	1	60	78	126	66 1/2	19 1/8	87	160	16	17 7/8	2	6 3/4	39 3/4	39 1/4	28 1/2	43	24		
2518	15800	815	15	2	815	25	1	60	78	139 1/2	77	21 1/4	92	184	16	20 3/4	3	6 3/4	40 1/4	39 3/8	32 5/8	50	24		
2520	16750	815	15	2	815	30	1	60	78	151	89 1/2	19 1/8	92	208	16	20 3/4	3	6 3/4	40 1/4	39 3/8	32 5/8	50	24		
268	8250	920	7 1/2	2	920	15	1	72	90	75 1/2	21	16 5/8	84 5/8	64	16	18	2	6 3/4	44 1/4	44 1/8	27 1/4	32 7/8	24		
2610	10300	920	10	2	920	15	1	72	90	90	30 1/2	16 5/8	87	88	16	17 7/8	2	6 3/4	45 3/4	45 1/4	28 1/2	43	24		
2612	11200	920	10	2	920	20	1	72	90	102	42 1/2	19 1/8	87	112	16	17 7/8	2	6 3/4	45 3/4	45 1/4	28 1/2	43	24		
2614	12750	870	10	2	870	20	1	72	90	114	54 1/2	19 1/8	87	136	16	17 7/8	2	6 3/4	45 3/4	45 1/4	28 1/2	43	24		
2616	14150	815	15	2	815	25	1	72	90	126	66 1/2	19 1/8	89 7/8	160	16	20 3/4	2	6 3/4	45 3/4	45 3/8	31 3/8	43	24		
2618	16900	770	20	2	770	30	1	72	90	139 1/2	77	21 1/4	92	184	16	20 3/4	3	6 3/4	56 1/4	45 3/8	32 3/8	50	24		
2620	18750	740	25	2	740	40	1	72	90	152	88 1/2	22 1/8	99 5/8	208	16	23 1/2	3	6 3/4	56 1/4	46 5/8	34 1/8	57	24		
2716	20200	740	25	2	740	40	1	84	102	131	61 1/2	22 1/8	99 5/8	160	16	23 1/2	3	8 3/4	62 1/4	52 5/8	34 1/8	57	26		
2718	21150	740	25	2	740	40	1	84	102	143	73 1/2	22 1/8	99 5/8	184	16	23 1/2	3	8 3/4	62 1/4	52 5/8	34 1/8	57	26		
2720	23050	740	25	2	740	40	1	84	102	154 1/2	86	22 1/8	99 5/8	192	24	23 1/2	4	8 3/4	62 1/4	52 5/8	35 1/8	57	26		
2816	21700	740	25	2	740	40	1	96	114	131	61 1/2	22 1/8	99 5/8	160	16	23 1/2	3	8 3/4	68 1/4	58 5/8	35 1/8	57	26		
2818	22850	740	25	2	740	40	1	96	114	143	73 1/2	22 1/8	99 5/8	168	24	23 1/2	4	8 3/4	68 1/4	58 5/8	35 1/8	57	26		
2820	24400	740	25	2	740	40	1	96	114	154 1/2	86	22 1/8	99 5/8	192	24	23 1/2	4	8 3/4	68 1/4	58 5/8	35 1/8	57	26		

▲ Number of springs per corner.

■ M dimension varies on Type SG - consult Syntron Material Handling.

♦ On SG Type 30 HP and 40 HP are mounted independent of vibrating screen.

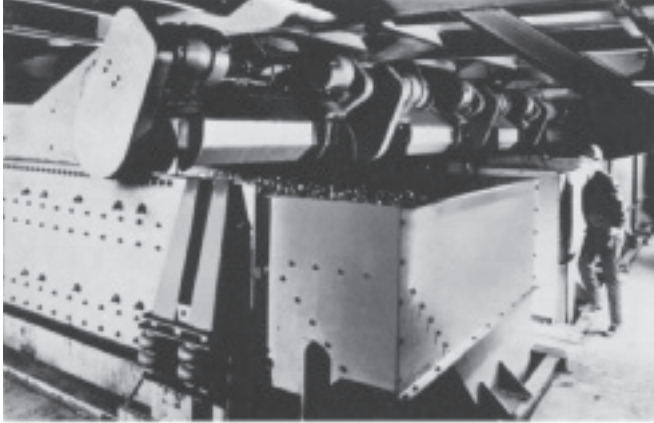

Two-deck Link-Belt® Model SS2816 dewatering screen in coal preparation plant.

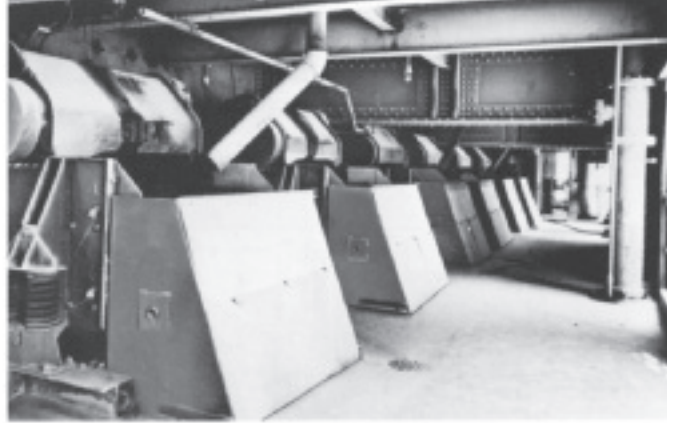

Twelve Link-Belt® Model SG2512 vibrating screens size limestone at a rate of 4,200 tons per hour.

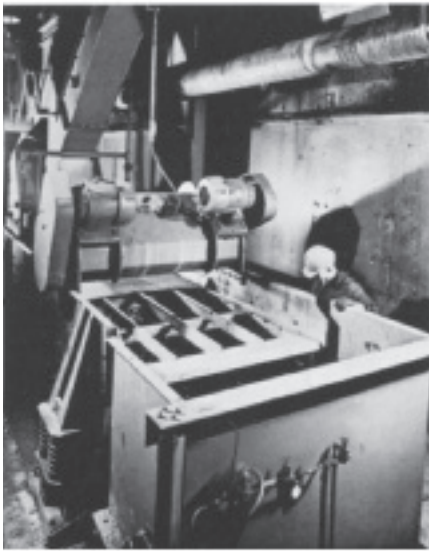

Link-Belt® Model SS2416 two-deck vibrating screen dewatering coal refuse.



Two Link-Belt® Model SG2616 straightline vibrating screens washing and sizing coal.

# Vibrating Screen optional features

Air springs provide maximum isolation of vibration for structures supporting vibrating screens. Their action is like that of a bellows, silently expanding or contracting with variations of load. These air springs are made of the same rugged nylon cord and high-strength rubber used in tubeless automotive tires. Any convenient air supply can be used for inflation.

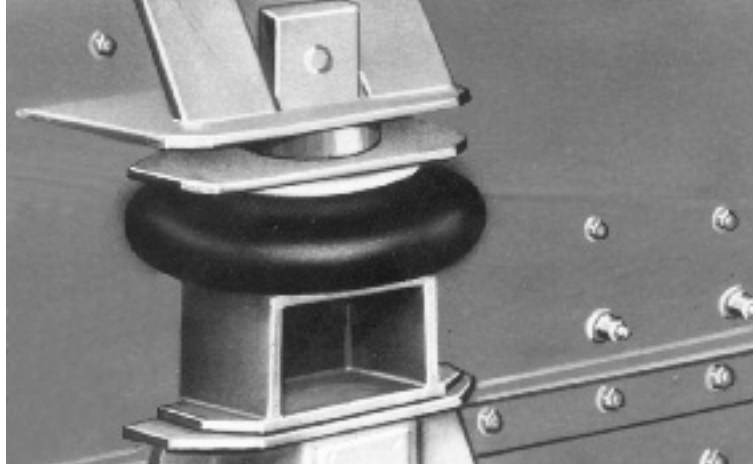

Bouncing ball decks dislodge on-size or near-size particles which have become wedged in the screen cloth. They are used primarily when processing moist or wet materials. A retaining deck is mounted below the sizing deck and is divided into small compartments which hold rubber balls. The screen's motion causes the balls to bounce against the wedged particles, driving them back to the screening surface.

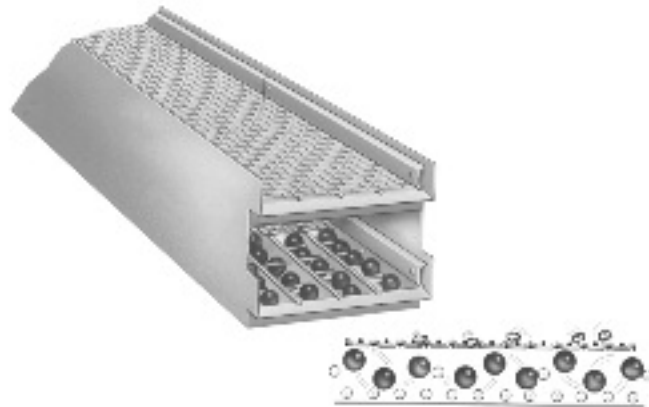

Electrically heated screen cloth can be used on Syntron Material Handling vibrating screens to prevent screen cloth blinding due to fine particles accumulating on the wires when handling sticky or hygroscopic materials. Screen cloth tensioning devices facilitate the flow of electricity from transformer to screen cloth, providing uniform heating with very low current consumption.

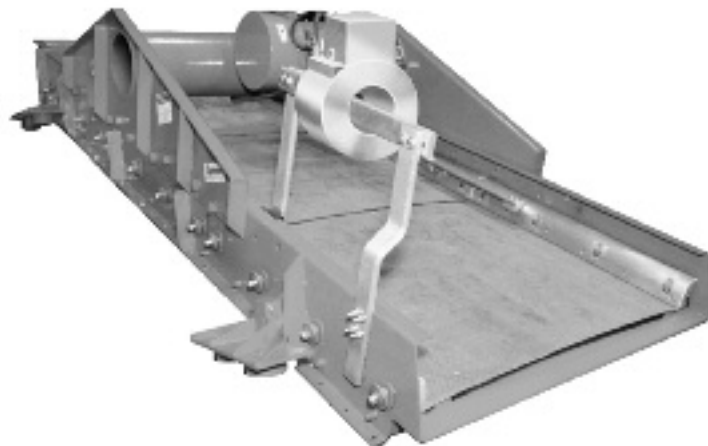

# Link-Belt® Foundry Shakeouts

## For fast, economical shakeout operations.

Link-Belt® Foundry Shakeouts range from standard light capacity to extra-heavy duty models to meet any shakeout application from floor molding to high production continuous operations.

Standard or custom designs coupled with proven experience insures effective separation of flask, castings and sand without damage to product or molding equipment.

Several optional features may be selected to tailor a Link-Belt® Foundry Shakeout to your specific needs. Choose from a variety of deck types. Single table units extend to 10' x 12'; but larger sizes can be furnished using dual or quad table assemblies.

## Model LS

Light duty Model LS Foundry Shakeouts are designed to handle loads up to 1,000 pounds in ferrous and nonferrous foundries. The high-speed elliptical motion efficiently separates the sand for the castings. The sand passes through the perforated deck plate while the castings are conveyed off the end of the deck for further processing.

Vibration is produced by unbalanced weight wheels located externally on an eccentric shaft. Shakeout deck vibration is easily field-adjusted by changing the angle of the weight wheels with respect to the eccentric shaft. The shakeout vibrator is completely enclosed, and the bearings are cartridge mounted and grease lubricated.

## Model MS and HS

Medium duty Model MS and heavy duty Model HS Foundry Shakeouts can be supplied horizontal for single shakeout operations or declined for continuous separation of sand and castings. Units can also be used for the simplified reclamation or reinforcing rods, gagers, sand and sprues.

Heat resistant, high alloy, square-end helical springs absorb impact forces and isolate dynamic forces from the supporting structures. Built-in sand hoppers on each model require a minimum of pit space to feed conveying equipment and protect the springs from hot sand. Vibrator mechanisms are completely enclosed, full floating, two bearing type. For ease in maintenance, the cartridge mounted, self-aligning spherical roller bearings are lubricated through channels into each cartridge.

Removable, perforated steel deck plates or bar decks can be furnished to suit specific applications. Perforated deck plates can be provided with or without skid bars. Both MS and HS units can be furnished in self-discharging versions for high production foundries. Both designs can be supplied for either grease or oil lubrication.

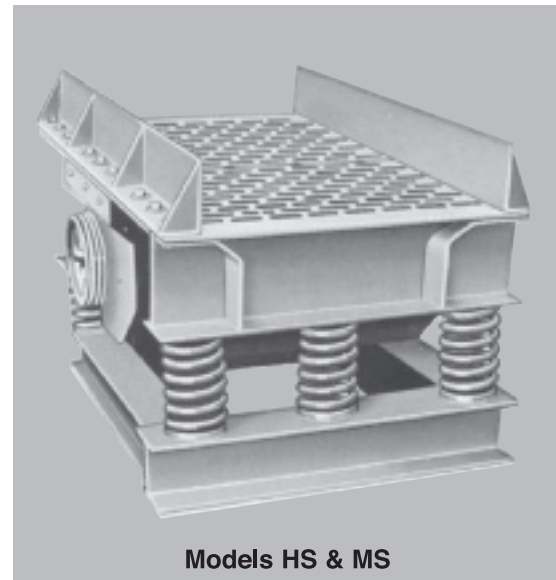
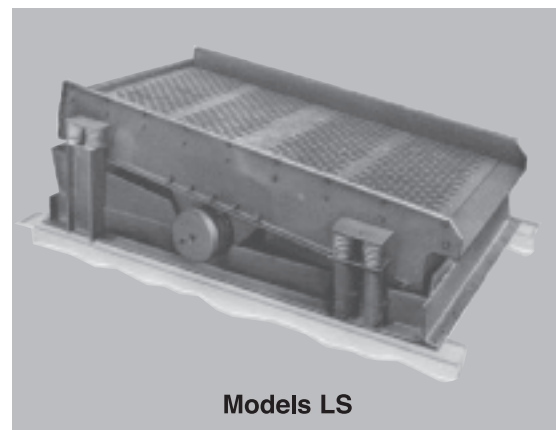



# Model AS

The Model AS Foundry Shakeout is a spring-mounted unit, designed to handle concentrated loads in heavy and extra-heavy duty applications.

A variety of sizes can be furnished to meet a wide range of capacity and deck area requirements. Multiple unit assemblies can be provided using two or four single units joined together. Selection of the size and number of units depends on the flask or casting size and the total weight to be applied to the deck. Capacities extend from 30,000 pounds up.

Model AS Shakeouts feature extra-heavy duty construction and materials to give maximum durability and freedom from distortion under massive loads. Each unit consists of a heavy welded subframe with built-in sand collection hopper beneath the grid deck, simplifying hopper supports and shakeout pit design. The one-piece cast grid deck is attached to the subframe with high strength bolts. Specially designed decks can be furnished with attachments for positioning flasks requiring extraordinary handling.

Optional equipment includes automatic grease and oil lubrication systems.



# Model FS

Model FS Foundry Shakeouts are designed for high production continuous shakeout operations. These units are ruggedly built for high impact loading, typical of punch-out and roll-over demolding stations. Straightline vibrating motion is not affected regardless of shakeout load, and provides positive conveying action and high efficiency separation of sand from castings.

Model FS Shakeouts are generally installed horizontal to 5-degree inclines. Stroke angle is easily adjusted to provide the flexibility to handle a wide variety of casting shapes, maintaining high travel speeds.

A low maintenance vibrator design offers reduced downtime and long service life. The vibrator consists of twin unbalanced shafts, supported by heavy-duty, self-aligning spherical roller bearings. The bearings are grease lubricated and cartridge mounted. Shafts are driven by large, alloy steel, precision helical gears. The lower gear operates in a large lubricant reservoir carrying oil to the upper gear. Jackscrews permit the easy removal of gears and bearing cartridges from the shaft, as well as the removal of bearings from the cartridge. A spring-loaded, automatic motor base maintains constant V-belt tension, and reduces belt wear. Optional features for the Model FS include perforated deck plates, louvered decks, grizzly decks and cast steel alloy grids. A modified version of this model, with a special sand conveying sub-deck, is also available.

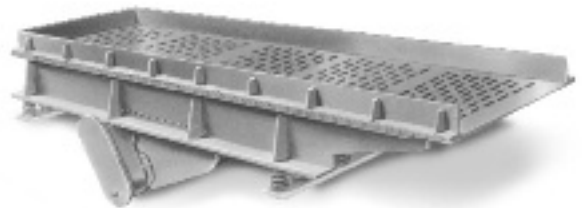

**CAUTION:** Syntron Material Handling Foundry Shakeouts must be installed, operated and maintained in accordance with our Service manual which is available at [www.syntronmh.com](http://www.syntronmh.com). Failure to follow these instructions can result in serious injury, property damage or both.

# Vibrating Grizzly Bar Screens

Syntron vibrating **Grizzly Bar Screens** are used in the basic industries to bypass fine particles that would otherwise clog or slow down crushing or reducing operations. These units are also used for laying a cushion of fines on a belt conveyor to protect the belt from damage by the fall of large, abrasive pieces; for removing large foreign objects from volume flow; or for any rough scalping or separating.

Each unit consists of a heavy-duty electromagnetic drive attached to a specially constructed grizzly bar trough. The troughs are built with a solid-steel plate area in the rear to absorb the impact and shock of loading large, heavy chunks of materials.

Suspension mounting is recommended for most grizzly bar screen applications. Units with below-deck drives can be floor mounted, but

the grizzly section should be suspension mounted. Grizzly bar screens with above-deck drive units are available upon request, and can only be suspension mounted.

Operation is from either 230.460 or 550 volt, 60 cycle, single phase a-c.

In addition to the electromagnetic designs outlined in this catalog, Syntron Material Handling also manufactures Vibrating Grizzly Bar Screens with electromechanical drive units. For complete details, contact a Syntron Material Handling applications specialist today at 800-356-4899.

## Specifications

Model	Power Consumption (watts*)	Current Input (Amps*)	Bar Spacing (inches)	Approx Net Wt. (Pounds)	Approx Shipping Wt. (Pounds)
<b>F-280</b>	550	11.2	1/2 to 1	475	600
<b>F-330</b>	950	23	1/2 to 1 1/4	1,075	1,500
<b>F-380</b>	1250	36	1/2 to 1 1/4	1,340	1,800
<b>F-440</b>	2200	40	1 1/2 to 3	2,275	2,700
<b>F-450</b>	2350	48	1 1/2 to 3	3,350	3,700
<b>F-480</b>	3300 †	35	1 1/2 to 3	4,350	4,700
<b>F-560</b>	2900 †	40	1 to 1 1/2	7,300	7,800
<b>F-660</b>	3300 †	35	1 1/2 to 4	8,500	9,000
<b>F-88</b>	4600 †	60 †	1 1/2 and up	11,500	12,000

\*230 volt, 60 cycle. † 460 volt, 60 cycle

Dimensions in Inches

Model	Trough Size	A	B	C	D	E	F	G	H	J
<b>F-280</b>	10 x 30	10	29 1/2	16 1/4	6	24 1/4	23	30	9 3/4	15
<b>F-330</b>	18 x 36	18	35 1/2	21 1/4	6	26 1/2	28	36	11	15
<b>F-380</b>	24 x 36	24	35 1/2	21 1/4	6	29 1/2	29 1/2	36	14	15
<b>F-440</b>	24 x 42	24	41 1/4	31 1/4	8	34	41	38 1/2	15 3/4	15
<b>F-450</b>	30 x 60	30	59	28 1/2	9	40 1/2	41 3/4	54	19 1/4	15
<b>F-450</b>	24 x 60	25	58 3/4	28 1/2	9	40 1/2	41	54	13 3/4	36
<b>F-480</b>	30 x 60	30	58 3/4	28 1/2	9	40 1/2	41 3/4	54	13 3/4	36
<b>F-480</b>	36 x 60	36	58 3/4	28 1/2	9	40 1/2	41 3/4	54	13 3/4	36
<b>F-560</b>	42 x 60	42	59	46	10	44 3/4	68 1/2	60	20 3/4	15
<b>F-560</b>	24 x 72	24	70 1/2	48	10	47 3/4	68 1/2	72	17 3/4	36
<b>F-560</b>	30 x 72	30	70 1/2	48	10	47 3/4	68 1/2	72	17 3/4	36
<b>F-660</b>	48 x 60	48	58 1/2	51	12	51 1/2	68 1/2	63	20 3/4	36
<b>F-660</b>	36 x 72	36	70 1/2	45	12	51 3/4	68 1/2	72	19 3/4	36
<b>F-88</b>	42 x 72	42	70 1/2	54	12	52 1/2	68 1/2	82	20 1/2	36
<b>F-88</b>	48 x 72	48	70 1/2	54	12	52 1/2	68 1/2	82	20 1/2	36
<b>F-88</b>	48 x 96	48	94 1/2	47 1/2	12	55 1/2	68 1/2	109 1/4	22 1/2	36

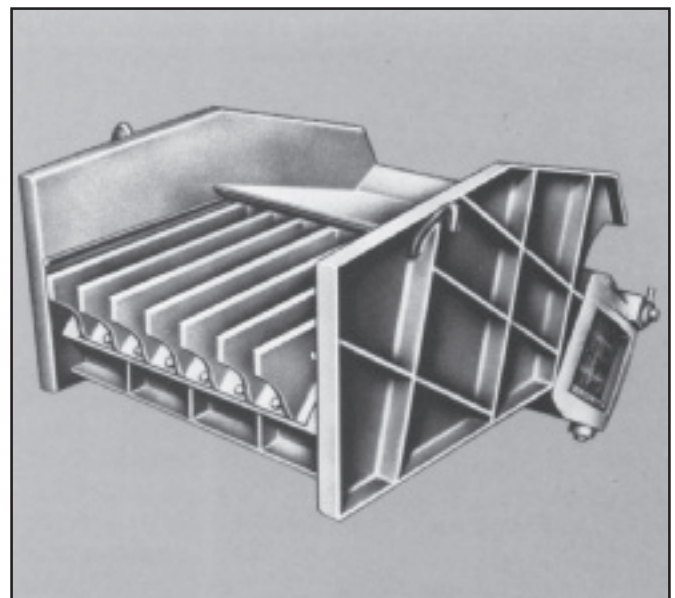



# **Syntron** Material Handling

## **Corporate Office**

P.O. Box 1370

Tupelo, Mississippi 38802

Phone: 662.869.5711

Fax: 662.869.7449

## **Proven Engineered Products – Complete Material Handling Solutions**

**Syntron<sup>®</sup>**  
**Link-Belt<sup>®</sup>**

### **Saltillo**

2730 Hwy 145 South

Saltillo, Mississippi 38866

Phone: 662.869.5711

Fax: 662.869.7493

Toll Free: 800.356.4898

info@syntronmh.com

### **Changshu**

#2 Road No. 1

Changshu Export Processing Zone

Changshu, Jiangsu, China 215513

Phone: +86 0512.52299002

Fax: +86 0512.52297228

info@syntronmh.com