

Syntron Material Handling

**Proven Engineered Products –
Complete Material Handling Solutions
for the Aggregate Industry**



www.syntronmh.com

Contents

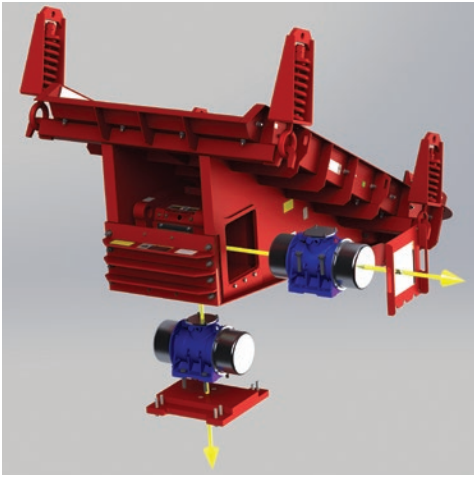

Syntron® MF Direct-Drive Electromechanical Feeders 4

SYNTRO-FLO Cone Crusher Loading Feeder by Syntron® 6

High Performance Electromagnetic Feeders 9



EVF Series Feeder Controls 10

Link-Belt® Ball Bearing Idlers 12

Link-Belt® Retrofit Rolls 14

Link-Belt® Composite Rolls 16

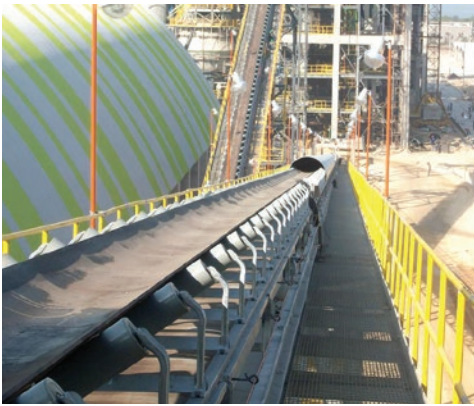

Syntron® Electromagnetic Vibrators 18



The World's Best **Link-Belt®** Idlers and **Syntron®** Feeders Are Built in Saltillo, Mississippi

When you're ready to purchase new feeders and idlers – performance, price, quality and dependability certainly impact your decision. Equally important is the name on the Product – Syntron Material Handling. Respected as an Aggregate Industry leader, Syntron® and Link-Belt® are names you can trust. Always have been.

Our company name is new, however, the Syntron® and Link-Belt® business principles remain the same. Quality. Quality. Quality. Whether built in the early 1900's or today, every Link-Belt® and Syntron® product is truly a labor of love and pride. Syntron Material Handling has the best and most experienced engineers, customer service and manufacturing expertise in the industry. A culture that focuses on innovation, quality manufacturing and excellence in customer service is led by an experienced and forward thinking senior management team.

While management leads the way, the real heartbeat of Syntron Material Handling is a team of employees that have taken idlers, feeders and material handling equipment to new levels of excellence. Many have fine-tuned their skills for more than 20, 30, 40 or even 50 years. Centering our entire operation in Saltillo, MS allows us to maintain the highest Quality Control Standards and on-time deliveries. All our products are produced to OSHA/MSHA standards and ISO Standard 9001:2008. We are happy to boast of being a founder and charter member of CEMA, active members of NSSGA, NMA, SME, FEMA, PTDA, and PMMI. For all your Aggregate needs contact the leader... Syntron Material Handling. Moving the World with Link-Belt® and Syntron® Brands.



Syntron® MF Direct-Drive Electromechanical Feeders

MF Direct-Drive Electromechanical Feeders

The high-capacity performers

Syntron® MF Direct-Drive Electromechanical Feeders are the heavy-weights of bulk material handling and are used for higher capacity requirements. The ten heavy-duty models handle capacities from 600 to 4,000 tons per hour.*

Syntron® MF Direct-Drive Electromechanical Feeders combine extra structural strength with durable components. The deep wing plates form a bridge between inlet and discharge suspension supports, providing extra strength for years of dependable service. Standard troughs feature unitized weldments – one-piece, completely welded units for greater strength. Troughs are also available with bolt-together construction for tunnel installations or other confined areas.

MF Direct-Drive Electromechanical Feeders are two-mass, spring-connected and sub-resonant-tuned. The exciter unit is connected to the trough with corrosion resistant polymeric springs, which are more stable under varying conditions. The springs are compressed for improved load stability, improved feed angles and straight line motion. The spring design eliminates pinch points, an important safety feature.

All Syntron® MF Direct-Drive Electromechanical Feeder motors are labeled for inverter duty and vibration service. Motors can be supplied to meet UL explosion-proof requirements.

*Based on sand weighing 100 pounds per cubic foot. Capacities vary depending on material characteristics, material density, trough length and width, trough liner type, feeder installation, skirt boards and hopper transitions.



Synro-Flo Crusher Loading Feeder with peripheral discharge

NEW! Two-Mass Direct-Drive

Most Syntron® MF Electromechanical feeders use the new Direct-Drive feature. This drive provides reliable service using a rotary vibrator to minimize components. Belts and pulleys, which commonly require adjustment and replacement due to wear, are eliminated. The new Two-Mass Direct-Drive is also maintenance friendly and requires minimal time for thrust adjustment or replacement.

Syntron® MF Direct-Drive Electromechanical Feeder Features

- Bottom and side access for quick replacement or adjustment
- Polymeric Drive Springs that do not rust or crack due to shock
- Over 80 years of design and engineering expertise and more importantly thousands upon thousands of proven installations
- Suspension / Isolation System with over 40 years of proven performance



Syntron® MF-600 Electromechanical Feeder feeding rock to a crusher.

MF Direct-Drive Electromechanical Feeder Features

- Operating frequency - 1100 VPM at 55.4 Hz
- Stroke: 0.25 - 0.30 inches
- Dependable, flexible, easily adjustable
 - Minimal component design to reduce adjustments and replacements due to wear
 - Quick replacement of Drive Unit
 - Infinite unbalance adjustment
 - VFD control providing 10:1 turn-down feed adjustment
- Sub-resonant tuning
 - Stroke consistency and speed stability under varying headload and material dampening
- Start and operate fully loaded or empty
- Structural strength
 - Deep wing plates
 - Engineered weldments using the latest FEA techniques and software
- Hazardous Area Service
 - Explosion proof motors
 - ULXP:
 - Class 1, Div 1, Group C & D
 - Class 2, Div 1, Group E, F, & G
- Bolt-in trough liners
 - T1-A
 - AR-400, AR-500
 - 304 stainless steel
 - Chromium carbide overlay ceramic
 - UHMW, TIVAR, rubber

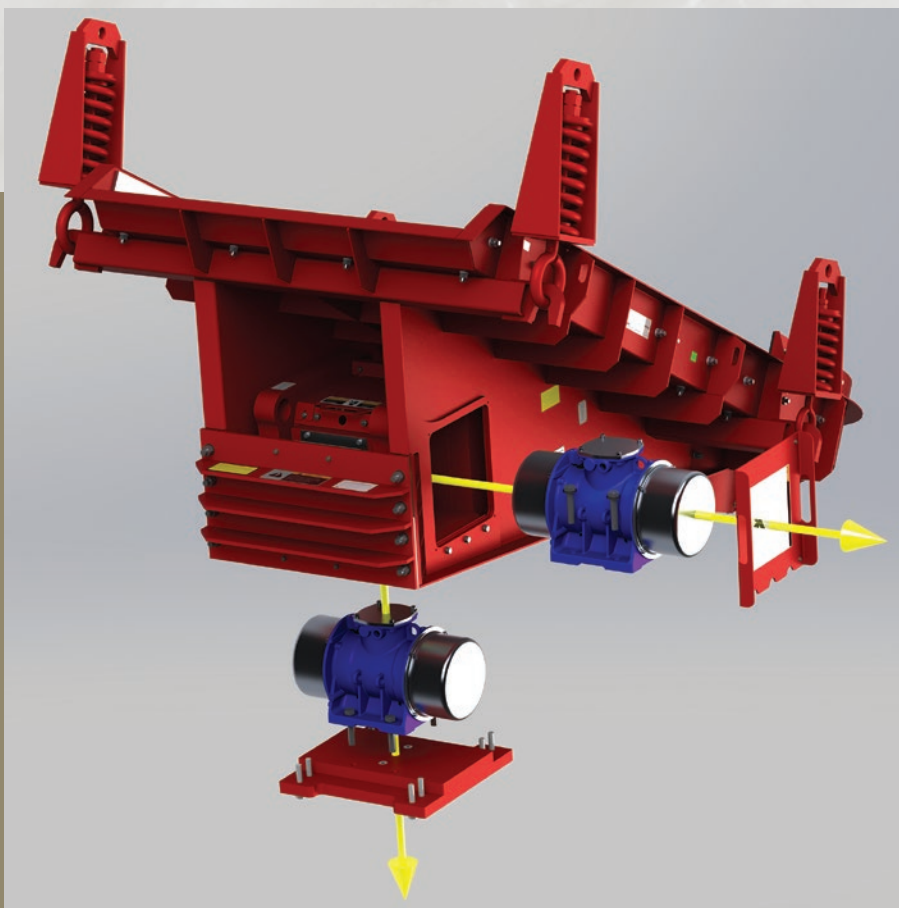

SYNTRO-FLO Cone Crusher Loading Feeder by **Syntron**[®]



4-inch rock being distributed through the peripheral discharge of the Crusher Loading Feeder.

Automated Crushing...

The whole purpose of automated crushing is to increase the productivity of the Cone or VSI (Vertical Shaft Impact) Crusher. Productivity is measured not only by the total tons/hour throughput, but by the average size reduction of the rocks and the resulting net finished product processed through the crusher. The ability to produce more tons/hour and achieve greater size reduction of rock is a function of the amount of energy that the crusher can put into the rock. This energy is measured by the crusher's electric motor amperage draw.

The SYNTRO-FLO Cone Crusher Loading Feeder by Syntron[®] is a Two-Mass Tuned Direct-Drive vibratory feeder with an engineered discharge uniquely designed for equal distribution of fine and coarse product. The trough including the discharge is fully lined to account for wear. Like traditionally designed feeders, it is suspension mounted, which can be easily integrated into a trolley system allowing it to be moved out of the way for crusher maintenance.

In side-by-side installations of a feeder-plus-rotary distributor versus a SYNTRO-FLO Cone Crusher Loading Feeder directly feeding the crusher, the SYNTRO-FLO unit delivered superior, cone-friendly performance. The uniform distribution provided by the SYNTRO-FLO unit increased crusher manganese life and yielded more uniformed product.



Blended material feeding directly from the Crusher Loading Feeder to the crusher.



Uniform distribution of material to the cone.



Features of SYNTRO-FLO Cone Crusher Loading Feeder by Syntron® include:

- Only one piece of equipment required
- More consistent amp draw on your crusher
- Longer life for crusher wear components
- Higher crusher productivity
- Reduced maintenance cost for the crusher
- Improved fracture ratio of the final product

Return on Investment

A typical 500 HP Cone Crusher will achieve increases in the amount of net finished product it crushes by **as much as 40%** when automated and fed by a SYNTRO-FLO cone crusher Loading Feeder by Syntron®.

At an average price of \$9.75/ton for -3/8" rock, an additional 100 tons/hour of net finished product will return an additional \$975 per hour in rock production, generating solid returns for your investment in crusher automation.

Increases productivity
Lowers operating costs



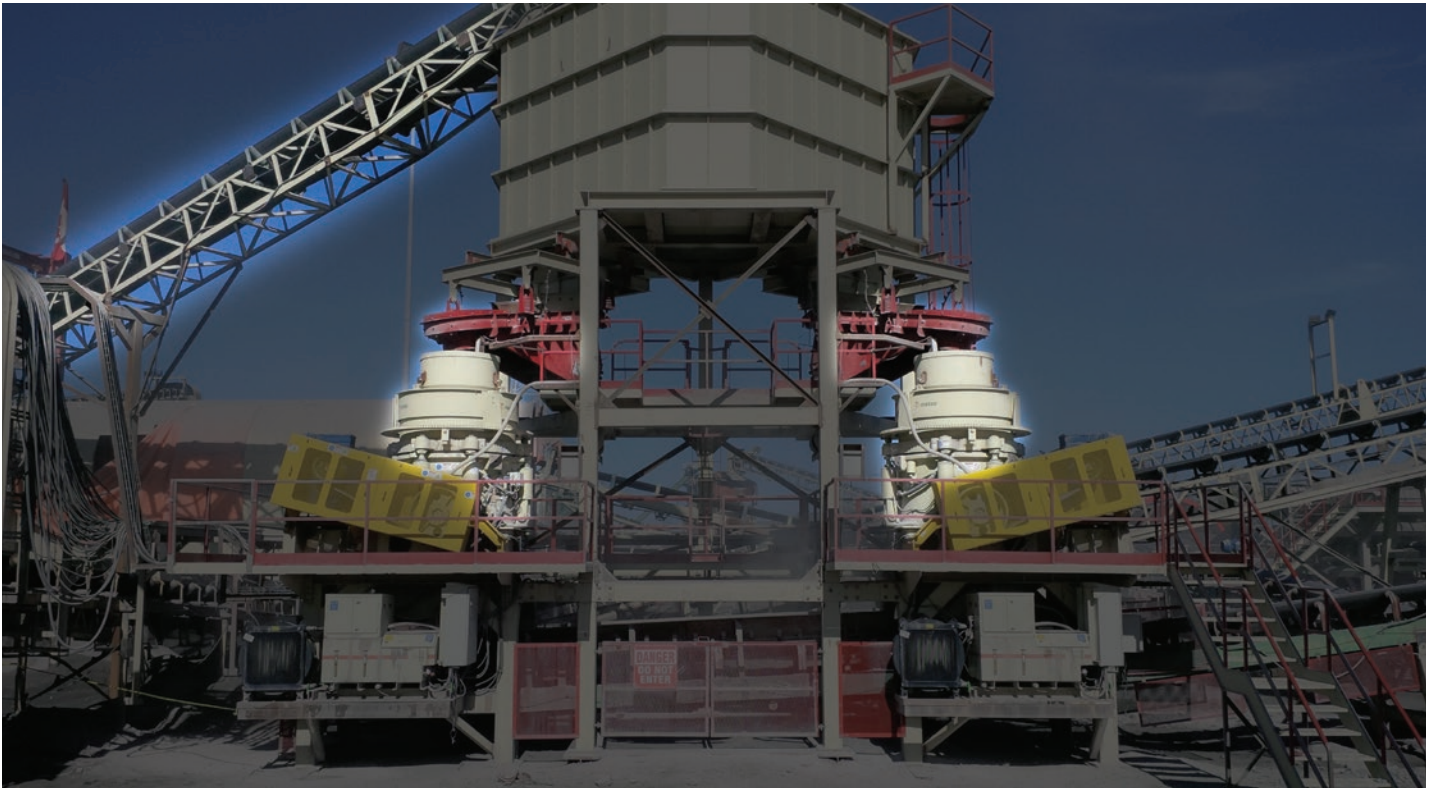

High Performance Electromagnetic Feeders

**40% capacity increase over
traditional units.**

- **Increase Capacity**
Increased travel speed increases capacity
(trough stroke .080", travel speed up to 60 ft/min)
- **Utilizes EVF Control**
Improved Power Factor, Lower KVA, Reduced
Power Consumption, and Improved Communication
Capabilities with Digital Control
- **3600 VPM Feeder Operation with 50 Hz Power**
NO reduction in feeder capacity due to 3000 cycle
per minute input
- **Low Maintenance**
NO motors, belts, bearings, or lubrication
- **Intermittent Operation**
Feeder can be switched on/off multiple times for
packaging and weigh bin applications
- **Sub-resonant Tuned**
Provides stability under headload
- **10:1 Turndown Capability**
- **Broad Ambient Temperature Range**
Sub-zero to 350 degrees F
- **Multiple Drive Arrangements**
Provide capability for wide and long
trough applications



Syntron®

High Performance Electromagnetic Feeder Features

The first name in vibration technology. Rugged and built to last, Syntron® bulk material handling equipment has a proven track record for reliable, low-maintenance performance for a wide range of industries and applications.



Heavy-Duty Electromagnetic Feeder Controls

EVF Series Control



Provide for adjustable and consistent material flow

EVF Series Controls are optimized for efficient operation and allow for a full range of material flow with a 10:1 turn-down ratio on electromagnetic feeders. The newly designed EVF line of feeder controls operate with single- or three-phase input providing half-wave (RC) output and are configured with custom firmware thus allowing for reduced power consumption.

Additional features of the new EVF product offering include precise voltage regulation, expanded DC control signals and PC communication, and improved diagnostic capability. Please reference the chart below for model offerings or call one of our applications specialists at 1-800-356-4898 for additional information.

Control Model	Input Voltage	Hz		Amps	Enclosure	Intermittent Contacts	DC Signal Input	Manual Control	Output RC	Voltage Regulation	Soft Start	Variable Frequency	Certifications		
		50	60										UL	CUL	CE
EVF-7.5D	230	●	●	20	Nema 1	●	●	Keypad	●	●	●	●	●	●	●
	380-460	●	●	10											
	575-600	●	●	10											
EVF-15D	230	●	●	40	Nema 1	●	●	Keypad	●	●	●	●	●	●	●
	380-460	●	●	21											
	575-600	●	●	15											
EVF-25D	230	●	●	60	Nema 1	●	●	Keypad	●	●	●	●	●	●	●
	380-460	●	●	34											
	575-600	●	●	25											
EVF-60D	380-460	●	●	75	Nema 1	●	●	Keypad	●	●	●	●	●	●	●
	575-600	●	●	64											
		●	●	64											

● Standard in the model listed

Electromagnetic Feeder Control Dimensions

Model	Feeder Type	Overall Dims (in.)				Mtg. Dims (in.)					Weight (lbs)	Weight (kg)
		A	B	C	D	E	F	G	H	J		
EVF-7.5D	FH-22-HP, FH-24-HP	7.88	12.72	7.22	3.01	7.31	11.93	0.28	0.12	-	18	8
EVF-15D	F-380-HP	7.88	12.72	7.22	3.01	7.31	11.93	0.28	0.12	-	29	13
EVF-25D	F-480-HP, F-660	9.84	15.90	8.08	4.33	8.90	15.12	0.39	0.39	-	29	13
EVF-60D	F-88	14.57	23.19	10.24	5.22	13.19	22.05	0.51	0.72	0.71	79	35

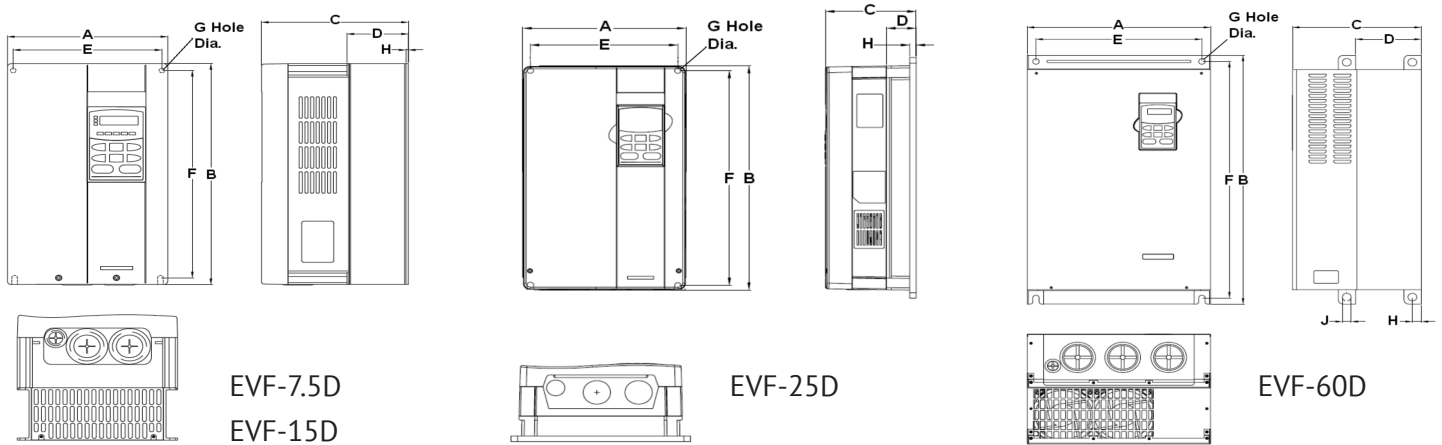

Return on Investment – Pays for itself upon installation

- Reduce the amperage by 85% utilizing PWM technology and a rectifier
- Design reduces KW consumption by 50%
- Reduced power grid installation cost
- Eliminates the reactive power losses - resulting in a reduction of up to 80% KVA requirement

Savings before startup include:

- Smaller transformers
- Smaller conductors (cables or wires)
- Smaller breakers
- Easier to install in MCC
- Less filtration and line conditioning required for other plant equipment
- Reduces the need for Power Factor Correction Equipment
- Easier to integrate with the latest technology for reduction in controls installation

Savings after startup include:

- Over a 50% reduction in energy consumed
- Better diagnostic capabilities to reduce maintenance time
- 100% voltage regulation for consistent production rates

Link-Belt® Ball Bearing Idlers with CEMA C Ratings

Idler Type	CEMA Rating	Bearing Type	Bearing/ Shaft Size	Service Rating
B2000	B	Ball	17 mm	Light to Medium
C2000	C	Ball	20 mm	Medium

CEMA Series B2000 Idlers

General Applications (Chemical, Agricultural, and Sand & Gravel)

Seal

- Rubber single lip contact seal paired with a polymer deflector with integrated labyrinth seal for robust, redundant sealing capability
- Seal works well in dusty conditions and wash down environments

Roll Thickness

- 4" diameter = 11 ga (0.120)
- 5" diameter = 11 ga (0.120)

Deep Groove Bearings

- Distance from the bearings and shaft ends is minimized to reduce shaft deflection at the bearings. Standard 2RS rubber seals add another level of protection against material and water. B2000 / 6203-2RS / 17mm

CEMA Series C2000 Idlers

General Applications (Pulp & Paper, Chemical, and Sand & Gravel)

Seal

- Rubber double lip contact seal paired with a polymer deflector with integrated labyrinth seal for robust, redundant sealing capability
- Seal works well in dusty conditions and wash down environments

Roll Thickness

- 5" diameter = 11 ga (0.120)
- 6" diameter = 11 ga (0.120)

Deep Groove Bearings

- Distance from the bearings and shaft ends is minimized to reduce shaft deflection at the bearings. Standard 2RS rubber seals add another level of protection against material and water. C2000 / 6304-2RS / 20mm

Features of both CEMA Series B2000 and C2000 Idlers

Frames

- Inverted angle frame base with slotted foot straps to ensure quick, easy mounting and alignment
- Heavy-duty, die-formed, steel end brackets are contoured for generous clearance to safeguard against spilled materials becoming jammed and impeding the rotation of the rollers
- All idler frames are welded in accordance with AWS D1.1 specifications for structural welds

CEMA

- Idlers meet or exceed CEMA requirements for rugged, continuous material handling
- Multiple belt widths and models available to meet your needs

Coatings

- Frames and rolls are powder-coated
- Assembly hardware is electro-zinc plated

Testing Capabilities

- Load rating
- Seal life
- Roll concentricity
- Roll resistance
- Roll imbalance
- Water resistance

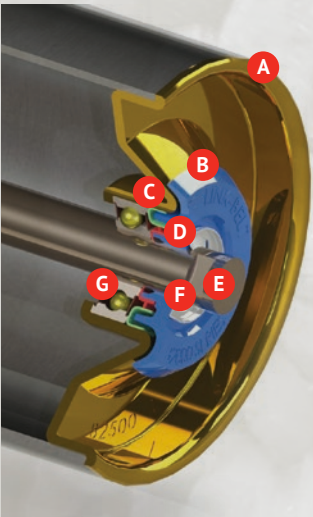

CEMA SERIES
B2000 IDLER

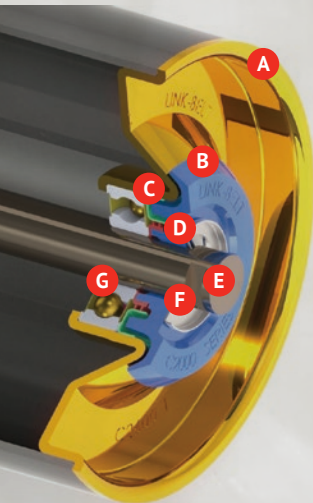

CEMA SERIES
C2000 IDLER

A. Pressed Head: Precision formed rigid pressed head. Designed to provide strength and rigidity while offering reduced weight. Excellent roll concentricity and balance. Yellow Zinc plated for corrosion resistance.

B. Deflector: Impact and corrosion resistant deflector provides first line protection against abrasive materials and washdown water.

C. Triple Labyrinth Seal: Durable, zinc plated inner metal labyrinth seal serves to fling out material and water while providing a smooth, corrosion resistant, heat conductive surface for the contact seal.

D. Contact Lip Seal: Special wear resistant contact seal provides sealing against abrasive fines and washdown water. Suitable for dry, wet, and cold temperature conditions.

E. Solid Shaft: High strength, cold finished low carbon C1018 shafting. Broached shaft end slots anchor the roll assembly securely to the frame.

F. Retaining Ring: Corrosion resistant stainless steel retaining ring eliminates any possible shaft end-play while firmly securing the roll assembly under load.

G. Deep Groove Bearings: Distance from the bearings and shaft ends is minimized to reduce shaft deflection at the bearings. Standard 2RS rubber seals add another level of protection against material and water.

Features of **Link-Belt®** Idlers include:

- Inventory in Stock for Quick Delivery
- Interchangeable Idler Assemblies
- Maintenance Free Sealed Ball Bearings
- Custom Powder Coating
- Competitive pricing without sacrificing performance
- Extra Bearing Protection via a High Performance Syntron External Sealing System

Link-Belt® Retrofits

CEMA B Retrofits

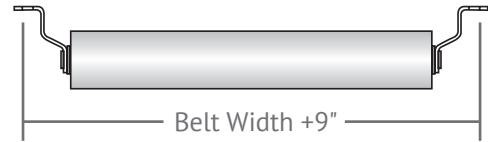
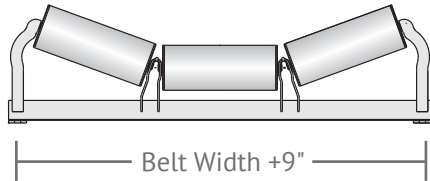

	Troughing Rolls		Returns / Carrying	
BW	4"	5"	4"	5"
14"	1726-265-A	1726-266-A	1726-265-L	1726-266-L
16"	contact factory for assistance	contact factory for assistance	1726-265-M	1726-266-M
18"	1726-265-C*	1726-266-C	1726-265-N*	1726-266-N
20"	1726-265-D	1726-266-D	1726-265-O	1726-266-O
24"	1726-265-E*	1726-266-E	1726-265-P*	1726-266-P
30"	1726-265-F*	1726-266-F	1726-265-Q*	1726-266-Q
36"	1726-265-G*	1726-266-G	1726-265-R*	1726-266-R
42"	1726-265-H	1726-266-H	1726-265-S	1726-266-S
48"	1726-265-I	1726-266-I	1726-265-T	1726-266-T

Call today for your Link-Belt® retrofit roll.

*Inventory Available in these belt widths.



Your Solution for Quality Cost Effective Link-Belt® Rolls while utilizing your existing footprint and frame design

CEMA C Retrofits

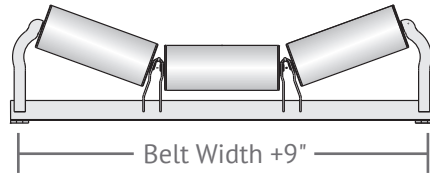

	Troughing Rolls		Returns / Carrying	
BW	5"	6"	5"	6"
18"	1726-267-A	1726-268-A	1726-267-AA	1726-266-AA
20"	1726-267-B	1726-268-B	1726-267-BB	1726-266-BB
24"	1726-267-C*	1726-268-C	1726-267-CC*	1726-266-CC
30"	1726-267-D*	1726-268-D	1726-267-DD*	1726-266-DD
36"	1726-267-E*	1726-268-E	1726-267-EE*	1726-266-EE
42"	1726-267-F*	1726-268-F	1726-267-FF*	1726-266-FF
48"	1726-267-G*	1726-268-G	1726-267-GG*	1726-266-GG
54"	1726-267-H	1726-268-H	1726-267-HH	1726-266-HH
60"	1726-267-I	1726-268-I	1726-267-II	1726-266-II

Call today for your Link-Belt® retrofit roll.

*Inventory Available in these belt widths.

Features of the Link-Belt® Retrofits include:

- Link-Belt® quality with retrofit capability
- Maintenance Free Sealed Ball Bearings
- Value Priced with CEMA Performance Ratings
- Inventory Available for Quick Delivery*
- Extra Bearing Protection via a High Performance External Seal
- Competitive pricing without sacrificing performance
- Quality Link-Belt® solutions for Problem Areas

Link-Belt® Composite Idler Rolls

Technical Data

What are Composite Idler Rolls?

- Syntron Material Handling introduces a revolutionary new idler roll made with state-of-the-art glass reinforced polyurethane.
- This tubing is a composite material consisting of layers of high quality glass fabric saturated with a two part thermoset polyurethane resin.
- Syntron Material Handling offers a 5" and a 6" diameter x 1/4" wall tubing size suitable for CEMA C, D and E roll applications (Syntron Material Handling C/D3500, C/D3600 & E4600 Series).
- Roll lengths are available for troughing, return, picking and V-return idlers with belt widths ranging from 18" to 72".
- Polyurethane pultruded composite tubing offers excellent mechanical properties similar to steel and superior to many traditional plastic resin roll products. The recommended operating temperature range is -40°F to +200°F.
- Syntron Material Handling composite rolls are extremely versatile and are suitable for many material handling applications*.
- Standard color: Traditional "Syntron Material Handling Orange"

*Currently not suitable in combustible environments, where possible static charge can cause an explosion hazard.



Features/Benefits

- **Excellent Strength**
Comparable tensile and flexural strength (lengthwise) to steel and aluminum. High strength-to-weight ratio.
- **Lighter Weight**
Material verses material: 75% lighter than steel and 30% lighter than aluminum. Approximately 50% lighter than traditional steel rolls. Easier installation, "Field Friendly" for maintenance and installation personnel, energy savings, and reduced noise.
- **Superior Toughness**
This glass fabric distributes loads to prevent surface damage. No permanent deformities. High impact strength. Crack resistant.
- **High Corrosion Resistance**
Superior resistance to a broad range of chemicals. Excellent in acid, alkali and salt spray environments. Low water absorption. Protective Polyurethane topcoat is suggested if exposed to UV rays during a long term storage.
- **High Abrasion Resistance**
Superior wear resistance to traditional thermoplastic resin rolls, resulting in longer shell life, longer belt life, and less maintenance.
- **Reduced Material Build-Up**
Polyurethane resin resists material build-up on the surface of the roll, thereby prolonging belt life.
- **Low Thermal Coefficient of Expansion**
Low coefficient of thermal expansion, comparable to steel, reducing differential expansion between shell, shaft, and the pressed head.
- **Environmentally Friendly**
Self extinguishing when exposed to flame in a horizontal position. Low carbon footprint compared to thermoplastic rolls. VOC Free.

Is corrosion eating away your profits?

Composite Idler Rolls are Ideal for replacement of steel rolls in corrosive environments.



Dimensional specifications match our CEMA C, D and E series steel products.



Features of the Link-Belt® Composite Idler Roll:

- Excellent Strength
- Lighter Weight
- Superior Toughness
- High Corrosion Resistance
- High Abrasion Resistance
- Reduced Material Build-Up
- Low Coefficient of Thermal Expansion
- Environmentally Friendly



Syntron® Vibrators

Your Needs – Our Solution

Criteria	Syntron Material Handling Capability
Relationship	Experienced representatives and distribution global network
Engineering expertise & support	80 years of vibratory manufacturing experience and history of successful installations globally
Improved productivity & throughput	High Frequency / Low Stroke
Localized vibration	Designed to introduce vibration to localized area, not vibrating support structure
Maintenance friendly & lower downtime	No rotating or sliding parts
Flexible design	Continuous or intermittent operation
Quality & Durability	Syntron® history of manufacturing products with long lifecycles
Value-based pricing	High quality products at a competitive price
On-time Delivery	Stock Items
Timely & Accurate Quotations	75 Years of Application experience
After-market parts and service	In country after market support on 5 continents

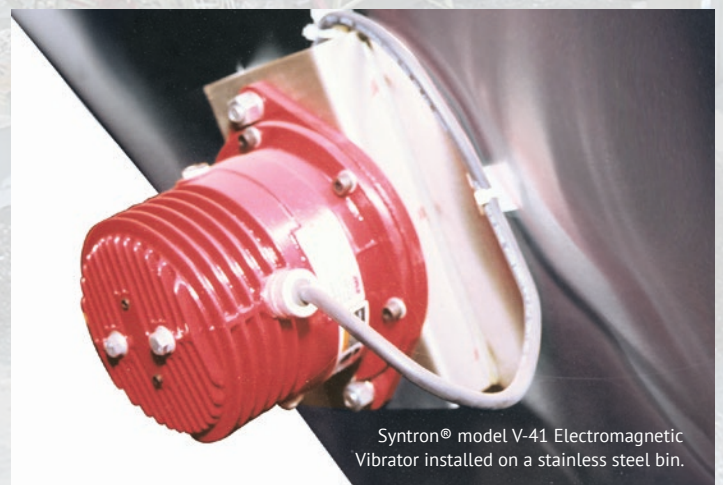
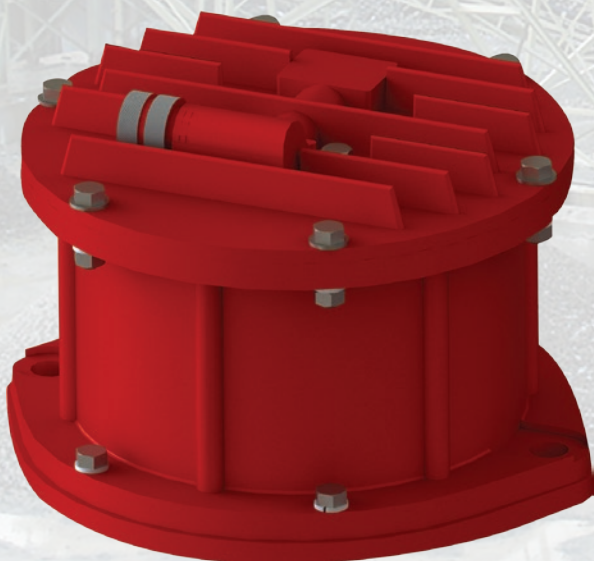



Syntron Material Handling

Proven Engineered Products – Complete Material Handling Solutions

Two powerful industry leading brands—Link-Belt® and Syntron®—have come together under a new company name, Syntron Material Handling, LLC, for one goal – better engineered products.

Established in May 2014, Syntron Material Handling (SMH) was built out of the legacies of Link-Belt® Company and Syntron Company, formerly owned by FMC Technologies. Today, our 300 skilled employees have a combined 4,212 years of industry knowledge that they put into the SMH product every day. We are dedicated to providing customers with complete material handling solutions.

Let Syntron Material Handling's knowledgeable team help your business with conveying, feeding, screening, elevating, vibratory flow aids, and mining controls of bulk product. Whether optimizing existing systems or starting from the ground-up on new and customized plants or mines, our dedicated staff will provide you with the most efficient and cost-effective solutions.

“Our company structure will be very exciting and fast-paced as we charter our new path. The positive attitudes and skills of our employees, the strength of our products, and our long-term customer relationships are our foundation for success.” said CEO Andy Blanchard.

An international leader for innovative solutions, Syntron Material Handling can improve the technology customers are already using. The Link-Belt® expertise and equipment have been instrumental in developing some of the world's largest belt conveyors. The Syntron® feeders are instrumental to supplying energy sources and material handling efforts across the globe.

Levine Leichtman Capital Partners, the new owner of Syntron Material Handling, is committed to the success and growth of the company by investing in engineering capabilities, manufacturing efficiency, and customer service.

Although we may have a new name, we still have the same dedicated employees and industry leading engineered products that make us a market leader.

Syntron Material Handling operates two manufacturing facilities in the USA and China.

All of our products are produced to OSHA/MSHA standards and ISO Standard 9001:2008. We are a charter member of CEMA, and active members of NSSGA, NMA, SME, FEMA, PTDA, and PMMI.



Syntron Material Handling

Corporate Office

P.O. Box 1370

Tupelo, Mississippi 38802

Phone: 662.869.5711

Fax: 662.869.7449

Proven Engineered Products – Complete Material Handling Solutions

Syntron®

Link-Belt®

Saltillo

2730 Hwy 145 South

Saltillo, Mississippi 38866

Phone: 662.869.5711

Fax: 662.869.7493

Toll Free: **800.356.4898**

info@syntronmh.com

Front cover image is
courtesy of Aggregates Manager.