

**Syntron** Material Handling

**Link-Belt®  
Underground  
Solutions**

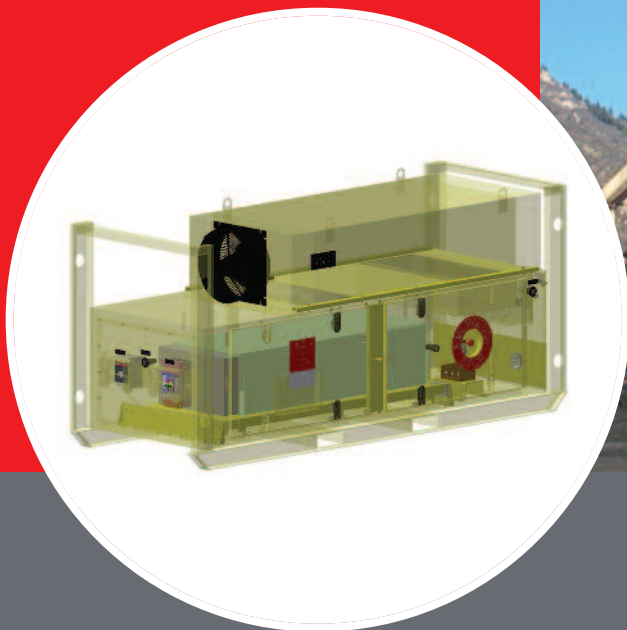

# Contents

Link-Belt® Underground Solutions

Syntron Material Handling	
Proven Engineered Products – Complete Material Handling Solutions .....	3
Link-Belt® Tapered Roller Bearing Idler Rolls .....	4
CEMA D3000 Series .....	6
CEMA E4000 Series .....	8
Rigid Belt Structure .....	10
Link-Belt® Ball Bearing Rolls for Retrofit Applications .....	12
CEMA F Severe Duty Rolls .....	13
Terminal Equipment .....	14
Discharge and Transfer Sections .....	15
Drives .....	16
Loading Sections .....	18
Belt Tensioning .....	19
Belt Storage/Accessories .....	20
Electric Winches .....	21
Conveyor Control Systems .....	22
Features – Standard Products .....	23
Single VFD Power Unit .....	24
Dual VFD Power Unit .....	25
Electric Winch VFD Power Unit .....	26
Electrocenter .....	27
Main Control Panel .....	28
Economy Control Panel .....	29



# Syntron Material Handling

## Proven Engineered Products – Complete Material Handling Solutions

Two powerful industry leading brands—**Link-Belt®** and **Syntron®**—have come together under a new company name, Syntron Material Handling, LLC, for one goal – better engineered products.

Established in May 2014, Syntron Material Handling (SMH) was built out of the legacies of Link-Belt Company and Syntron Company, formerly owned by FMC Technologies. Today, our 300 skilled employees have a combined 4,212 years of industry knowledge that they put into the SMH product every day. We are dedicated to providing customers with complete material handling solutions.

Let Syntron Material Handling’s knowledgeable team help your business with conveying, feeding, screening, elevating, vibratory flow aids, and mining controls of bulk product. Whether optimizing existing systems or starting from the ground-up on new and customized plants or mines, our dedicated staff will provide you with the most efficient and cost-effective solutions.

*“Our company structure will be very exciting and fast-paced as we charter our new path. The positive attitudes and skills of our employees, the strength of our products, and our long-term customer relationships are our foundation for success.”* said CEO Andy Blanchard.

An international leader for innovative solutions, Syntron Material Handling can improve the technology customers are already using. The Link-Belt® expertise and equipment have been instrumental in developing some of the world’s largest belt conveyors. The Syntron® feeders are instrumental to supplying energy sources and material handling efforts across the globe.

Levine Leichtman Capital Partners, the new owner of Syntron Material Handling, is committed to the success and growth of the company by investing in engineering capabilities, manufacturing efficiency, and customer service.

Although we may have a new name, we still have the same dedicated employees and industry leading engineered products that make us a market leader.

Syntron Material Handling operates two manufacturing facilities in the USA and China.

All of our products are produced to OSHA/MSHA standards and ISO Standard 9001:2008. We are a charter member of CEMA, and active members of NSSGA, NMA, SME, FEMA, and PMMI.



**Call us today for all your material handling needs.**

**Saltillo**  
2730 Hwy 145 South  
Saltillo, Mississippi 38866  
Phone: 662.869.5711  
Fax: 662.869.7493  
**800.356.4898**  
orders@syntronmh.com

**Changshu**  
#2 Road No. 1  
Changshu Export Processing Zone  
Changshu, Jiangsu, China 215513  
Phone: +86 0512.52299002  
Fax: +86 0512.52297228



# Link-Belt® Tapered Roller Bearing Idler Rolls

Link-Belt Tapered Bearing Idler Rolls are perfectly suited for continuous material handling operations moving massive volumes of tough, abrasive materials such as coal, iron ore, and rock products. Boasting load ratings that exceed CEMA requirements, this rugged line is available in CEMA D, E and F series models. Each roller is equipped with a solid carbon steel shaft for minimum deflection under load, resulting in increased service life.

## Advanced Sealing System

Link-Belt sealed for life tapered roller bearing idlers feature factory-lubricated and sealed for life rolls which eliminates relubrication maintenance costs. They feature a triple lip rubber contact seal paired with a nylon deflector nut and integrated labyrinth seal that protects the precision tapered roller bearings in several ways. The outer deflector nut features a 90° contoured lip to deflect material away from the roll end. The triple lip contact seal and grease-filled labyrinth ensure against the ingress of performance-inhibiting contaminants.

## Maximum Corrosion Protection

Link-Belt rolls are protected from corrosion by a polymeric powder coating baked on at high temperatures to provide resistance to abrasive elements. Outer adjusting nuts and assembly hardware are zinc-plated to minimize corrosion and ensure extended service.





## Link-Belt® CEMA Idler Product Offering

Idler Type	CEMA Rating	Bearing Type	Bearing/ Shaft Size	Service Rating
D2000	D	Ball	30 mm	Heavy
D3000	D	TRB	3/4 in	Heavy
E2000	E	Ball	40 mm	Heavy/Severe
E4000	E	TRB	1 1/4 in	Heavy/Severe
F5000	F	TRB	1 3/4 in	Extreme



# CEMA D3000 Series

## Bearings

- Precision tapered roller bearings with modified geometry; LM11900 with  $\frac{3}{4}$ " bore
- Bearings/shaft are designed to accommodate bearing misalignment under fully rated loads
- L10 bearing life > 60,000 hrs @ 500 rpm, exceeds load ratings of 6306 ball bearing products

## Underground Frames

- Box frame with offset center roll, can be supplied with channel or wire rope clamps
- Heavy-duty, die-formed, steel end brackets are contoured for generous clearance to safeguard against spilled materials becoming jammed and impeding the rotation of the rollers
- All idler frames are welded in accordance with AWS D1.1 specifications for structural welds

## Seal

- The outer adjusting nuts are zinc plated, machined steel, to minimize corrosion
- Rubber triple lip contact seal paired with a nylon deflector nut with integrated labyrinth seal for robust, redundant sealing capability
- Seal works well in dusty conditions and wash down environments

## Coatings

- Frames and rolls are powder-coated
- Assembly hardware is electro-zinc plated

## CEMA

- Idlers meet or exceed CEMA requirements for rugged, continuous material handling
- Multiple belt widths and models available to meet your needs

## Roll Thickness

- 5" diameter = 9 ga (0.148)
- 6" diameter = 8 ga (0.165)
- 4" diameter rolls are available
- 0.180" and  $\frac{1}{4}$ " thick steel rolls are optional

## Testing Capabilities

- Load rating
- Seals
- Roll concentricity
- Roll resistance
- Roll imbalance
- Water resistance

### Available Idler Roll Types:

- Rubber lagged impact or rubber tread rolls
- Rubber lagged impact center roll
- Scale idler
- Urethane coated or lagged rolls
- Galvanized frame

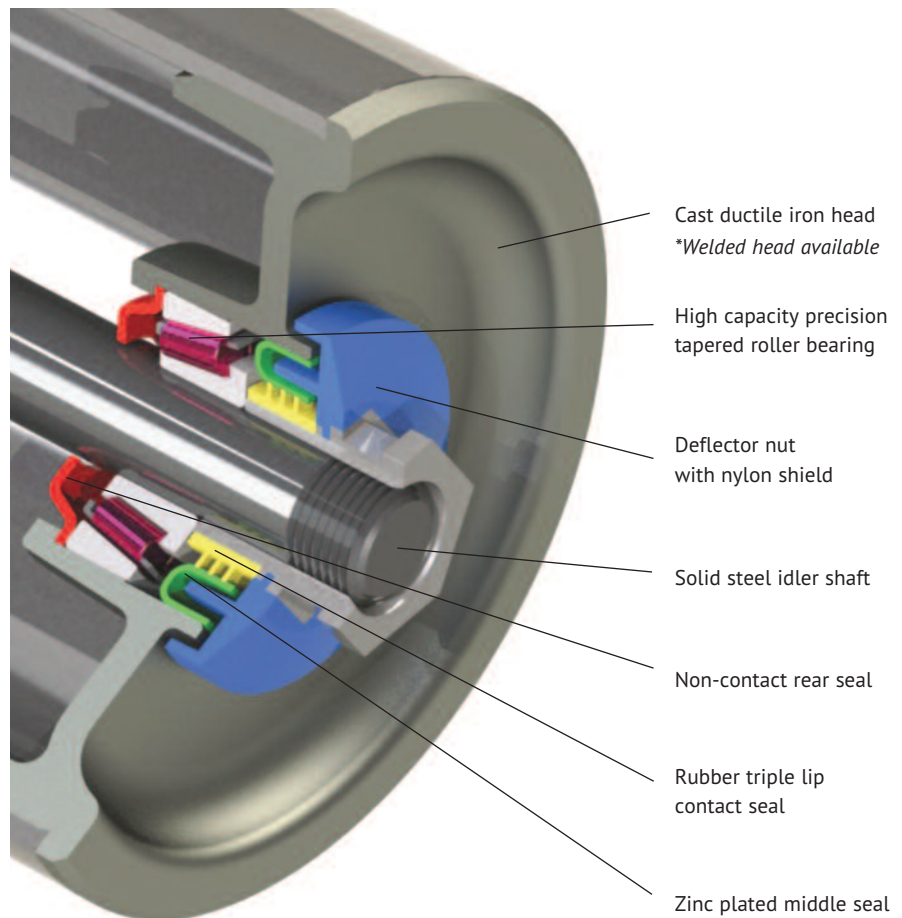

# CEMA D3000 Series

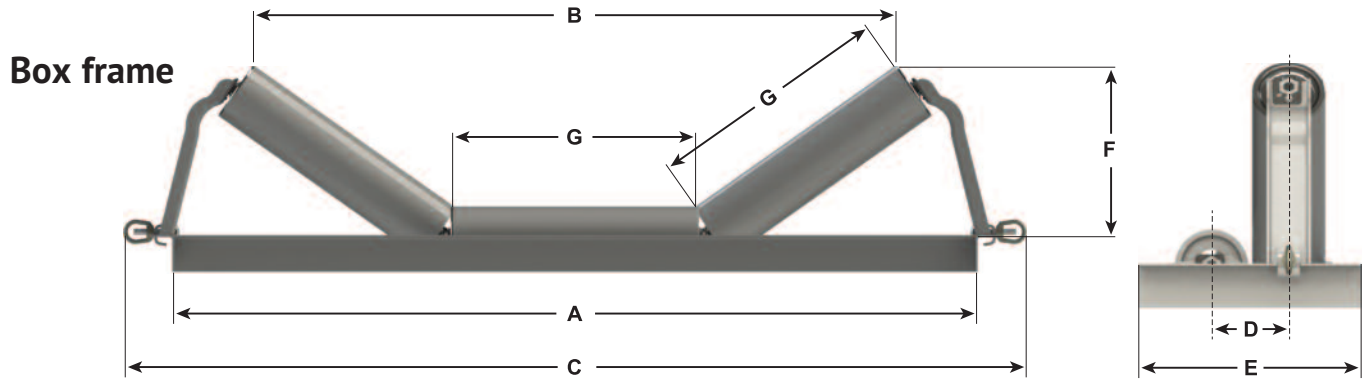

CEMA D Box Frame Idler									
Belt Width	Roll Dia.	Part Number	A	B	C	D	E	F	G
36	5"	1742-748-C	47.25	36.31	55.50	5.25	14.25	10.44	14.12
	6"	1742-750-C	47.25	35.88	55.50	6.25	16.25	10.88	14.12
42	5"	1742-748-D	53.25	41.56	61.50	5.25	15.25	11.62	16.12
	6"	1742-750-D	53.25	41.12	61.50	6.25	17.25	12.00	16.12
48	5"	1742-748-E	59.25	46.88	67.50	5.25	15.25	12.75	18.12
	6"	1742-750-E	59.25	46.44	67.50	6.25	17.25	13.19	18.12
54	5"	1742-748-F	65.25	52.12	73.50	5.25	15.25	13.88	20.12
	6"	1742-750-F	65.25	51.69	73.50	6.25	17.25	14.31	20.12
60	5"	1742-748-G	71.25	57.44	79.50	5.25	15.25	15.06	22.12
	6"	1742-750-G	71.25	57.00	79.50	6.25	17.25	15.44	22.12

NOTE: Wire rope clamps are standard. For channel clamps, add .C to the part number, as in 1742-748-G.C.

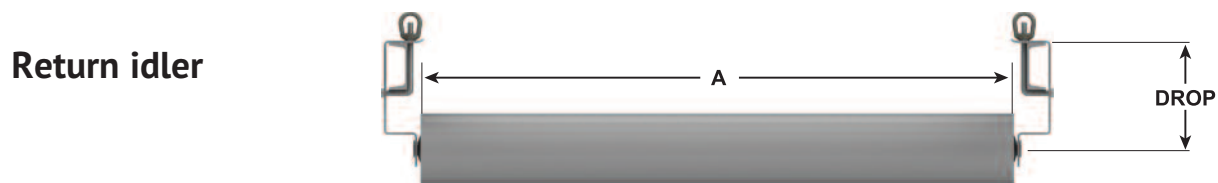

CEMA D Return Idler				
Belt Width	Roll Dia.	Roll Part Number	A	Drop
36	5"	1730-341-R.S	44.62	9", 12" or 15"
	6"	1730-342-R.S		
42	5"	1730-341-S.S	50.62	
	6"	1730-342-S.S		
48	5"	1730-341-T.S	56.62	
	6"	1730-342-T.S		
54	5"	1730-341-U.S	62.62	
	6"	1730-342-U.S		
60	5"	1730-341-W.S	68.62	
	6"	1730-342-W.S		

CEMA D Drop Brackets			
	9" Drop	12" Drop	15" Drop
3" Channel	1747-219-A	1747-219-B	1747-219-C
4" Channel	1747-221-A	1747-221-B	1747-221-C
5" Channel	5118-311-A	5118-311-B	5118-311-C

Notes: Other sizes and styles are available upon request.  
V-Return idlers also available.

For belt widths greater than 60 inches, call Syntrol Material Handling for application assistance.

# CEMA E4000 Series

## Bearings

- Precision tapered roller bearings with modified geometry; LM67000 with 1-1/4" bore
- Bearings/shaft are designed to accommodate bearing misalignment under fully rated loads
- L10 bearing life > 60,000 hrs @ 500 rpm, exceeds load ratings of 6308 ball bearing products

## Underground Frames

- Box frame with offset center roll, supplied with channel clamps and handles to allow for easy mounting
- Heavy-duty, die-formed, steel end brackets are contoured for generous clearance to safeguard against spilled materials becoming jammed and impeding the rotation of the rollers
- All idler frames are welded in accordance with AWS D1.1 specifications for structural welds

## Seal

- The outer adjusting nuts are zinc plated, machined steel, to minimize corrosion
- Rubber triple lip contact seal paired with a nylon deflector nut with integrated labyrinth seal for robust, redundant sealing capability
- Seal works well in dusty conditions and wash down environments

## Coatings

- Frames and rolls are powder-coated
- Assembly hardware is electro-zinc plated

## CEMA

- Idlers meet or exceed CEMA requirements for rugged, continuous material handling
- Multiple belt widths and models available to meet your needs

## Roll Thickness

- 6" diameter = 8 ga (0.165), 0.180" or 0.250" are available
- 7" diameter = 0.250"

## Testing Capabilities

- Load rating
- Seals
- Roll concentricity
- Roll resistance
- Roll imbalance
- Water resistance

### Available Idler Roll Types:

- Rubber lagged impact or rubber tread rolls
- Rubber lagged impact center roll
- Scale idler
- Urethane coated or lagged rolls
- Galvanized frame

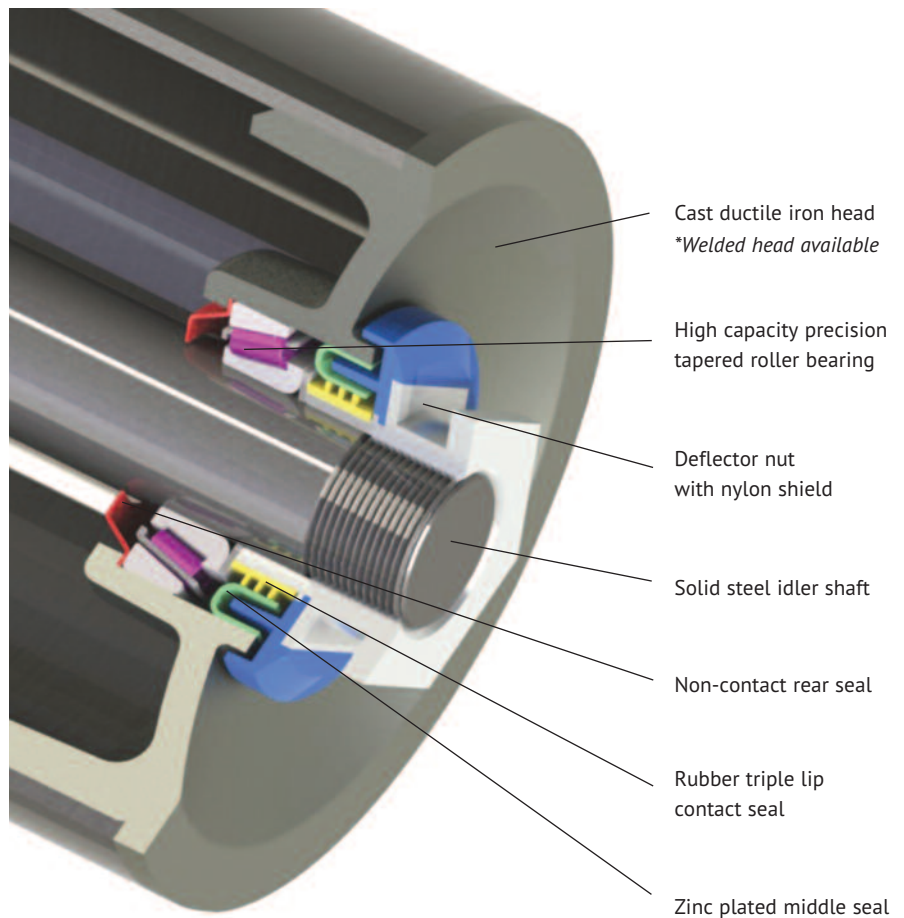



# CEMA E4000 Series

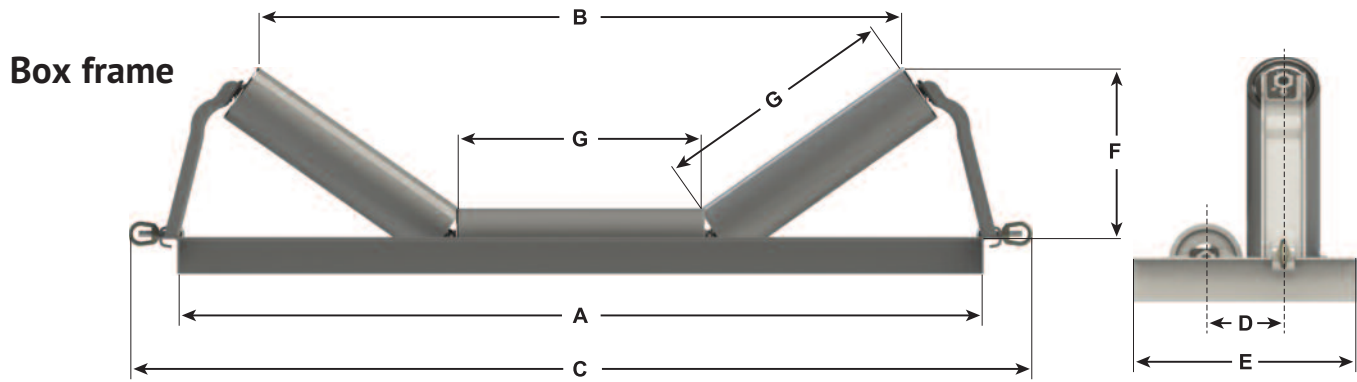

CEMA D Box Frame Idler									
Belt Width	Roll Dia.	Part Number	A	B	C	D	E	F	G
54	6"	5113-966-D.S	65.25	54.34	75.38	6.38	16.38	14.96	20.12
	7"	5308-130-D.S	65.25	53.90	75.38	7.38	18.38	15.34	20.12
60	6"	5113-966-E.S	71.25	57.38	81.38	6.38	16.38	15.56	22.12
	7"	5308-130-E.S	71.25	56.94	81.38	7.38	18.38	15.94	22.12
72	6"	5113-966-F.S	83.25	67.93	93.38	6.38	16.38	17.88	26.12
	7"	5308-130-F.S	83.25	67.49	93.38	7.38	18.38	18.32	26.12

**NOTE:** Channel clamps are standard for CEMA E box frame idlers.

6-inch rolls have 8 ga. shells. Other gauges and belt widths are available; call your Syntron Material Handling Customer Service Representative for assistance.

## Return idler

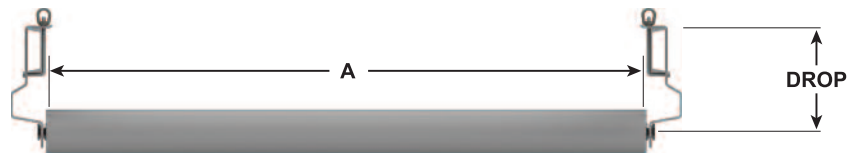

CEMA E Flat Return Roll				
Belt Width	Roll Dia.	Roll Part Number	A	Drop
54	6"	1730-319-E.S	63.88	14"
	7"	1730-423-E.S		
60	6"	1730-319-J.S	69.88	
	7"	1730-423-J.S		
72	6"	1730-319-L.S	81.88	
	7"	1730-423-L.S		

CEMA E, Extra Clearance Drop Brackets	
	14" Drop
4" Channel	1747-207-C
5" Channel	1747-207-A
6" Channel	1747-207-B

**Notes:** Other sizes and styles are available upon request.  
V-Return idlers also available.

For belt widths greater than 72 inches, call Syntron Material Handling for application assistance.

# Rigid Belt Structure

Larger volumes of tonnage being produced by improved mining techniques created a need for heavier conveyor construction to handle these loads, while maintaining flexibility and short move-up times. Link-Belt® rigid channel construction fulfills these requirements. Rigid stringer construction can be furnished using 3" - 6" channel as required. Both floor mounting and roof mounting are available.

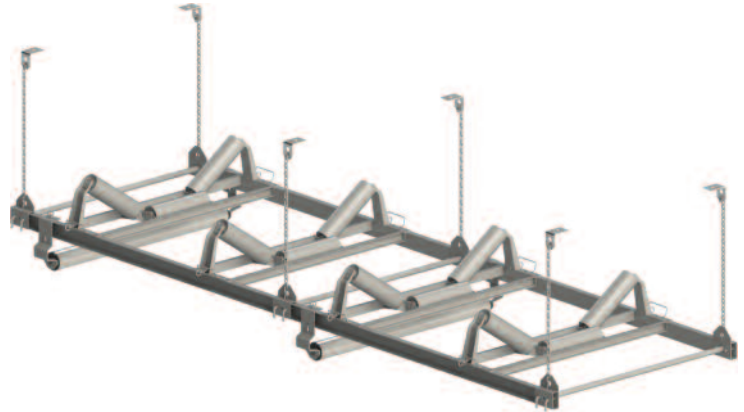

## Roof-Hung Rigid Structure

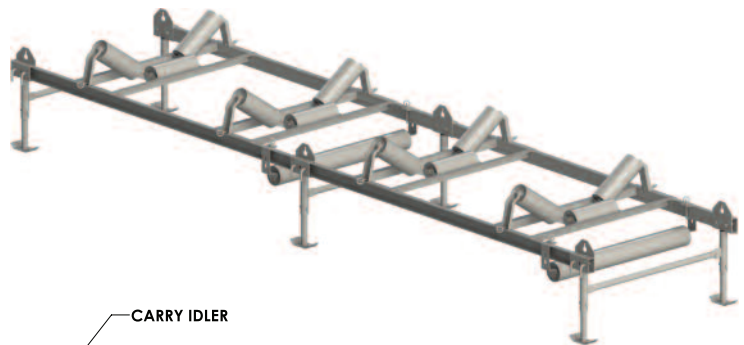
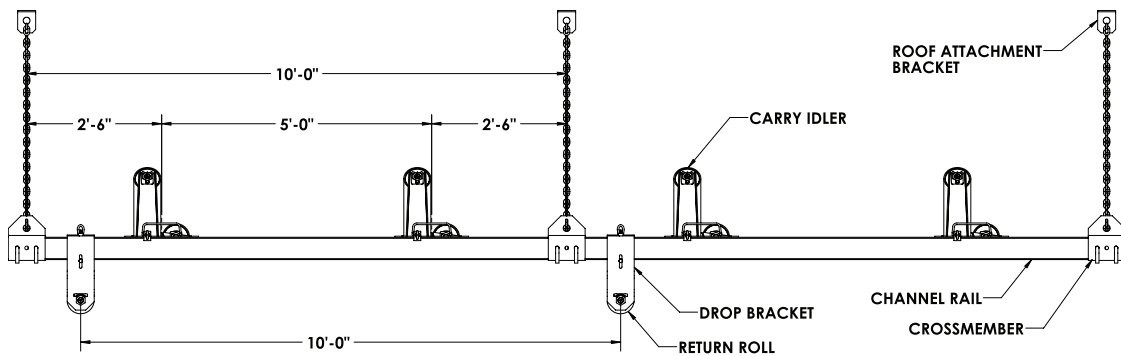

## Floor Mounted Rigid Structure

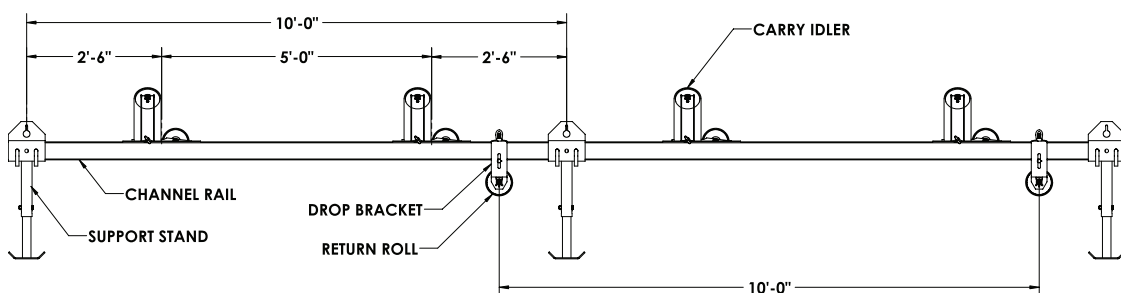

**Note: Catenary and Wire Rope options are available.**

# Rigid Structure Accessories

## Rigid Channel



Rigid Channel, 10 ft. Nominal Length				
Channel Size	C3 x 4.1	C4 x 5.4	C5 x 6.7	C6 x 8.2
Part Number	5081-053-001	5081-053-002	5081-053-003	5081-053-004

## Channel Crossmember

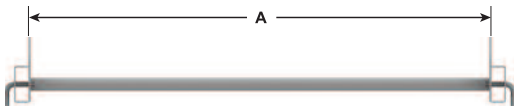

Channel Crossmember			
Belt Width	Channel Size	Part Number	A
36	C3 x 4.1	1431-089-C	47.38
	C4 x 5.4	1431-090-C	
42	C3 x 4.1	1431-089-D	53.38
	C4 x 5.4	1431-090-D	
48	C4 x 5.4	1431-090-E	59.38
	C5 x 6.7	1431-091-E	
54	C4 x 5.4	1431-090-F	65.38
	C5 x 6.7	1431-091-F	
60	C4 x 5.4	1431-090-G	71.38
	C5 x 6.7	1431-091-G	
72	C5 x 6.7	1431-091-H	83.38

## Channel Support Stand

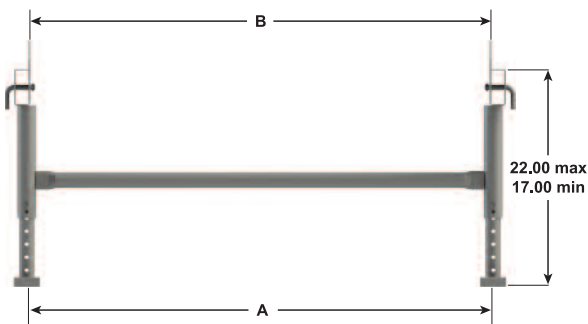

Channel Support Stand, 9" Return Drop				
Belt Width	Channel Size	Part Number	A	B
36	C3 x 4.1	1431-114-B	48	47.38
	C4 x 5.4	1431-112-B		
42	C3 x 4.1	1431-114-C	54	53.38
	C4 x 5.4	1431-112-C		
48	C4 x 5.4	1431-112-D	60	59.38
	C5 x 6.7	1431-109-D		
54	C4 x 5.4	1431-112-E	66	65.38
	C5 x 6.7	1431-109-E		
60	C4 x 5.4	1431-112-F	72	71.38
	C5 x 6.7	1431-109-F		

Note: Other styles are available upon request.



## Link-Belt Ball Bearing Rolls for Retrofit Applications

Link-Belt ball bearing rolls, offered in CEMA D and E series, are well suited for retrofit and replacement roll applications. Retrofit rolls can be designed specifically for use in your existing idler frames.

Link-Belt® D2000 rolls feature 30 mm ball bearings, Syntron Material Handling's proprietary interference-fit pressed heads, and a quad horizontal labyrinth outer seal, a delrin outer labyrinth member, a dual lip nitrile rubber inner seal and contact seals on both sides of the bearings. D2000 rolls are designed for harsh, medium to heavy-weight applications and are available for belt widths from 18 to 72 inches, and 20°, 35° and 45°troughed belt idlers, flat return and v-return idlers in 5" and 6" diameters.

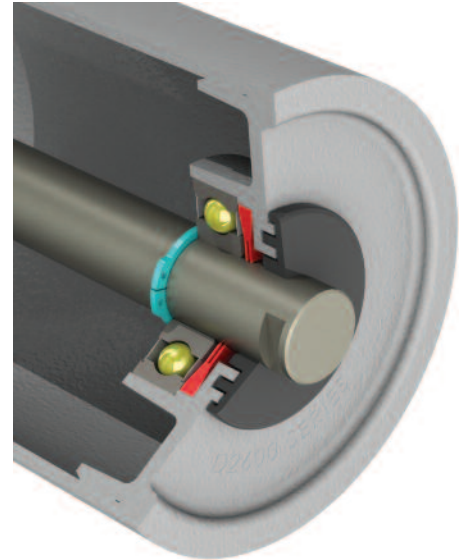

Link-Belt® E2000 rolls are designed for the rugged, maximum capacity and continuous handling requirements of heavy, coarse and abrasive materials such as coal, iron ore, copper, large stone and overburden. Featuring an exceptionally robust seal design and 40 mm ball bearings, E2000 rolls are available for belt widths from 36 to 96 inches, and 20°, 35° and 45°troughed belt idlers, flat return and v-return idlers in 6" and 7" diameters.

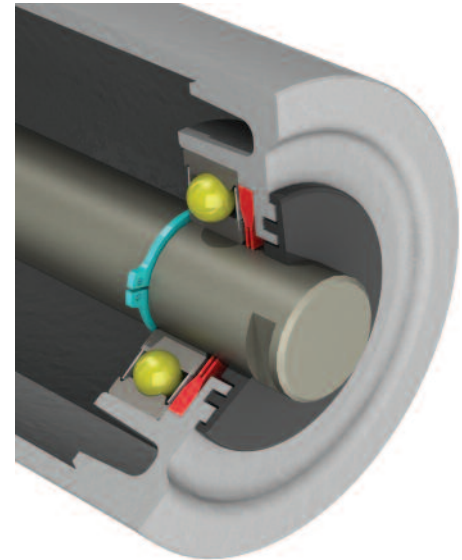

## CEMA F Severe Duty Rolls

Link-Belt® F5000 rolls are designed for the most extreme duty material handling applications. They feature a triple lip rubber contact seal paired with a machined steel deflector nut and integrated labyrinth seal that protect the 1-3/4" tapered roller bearings. F5000 rolls are available in 6", 7", and 8" diameters for belt widths up to 120 inches, and come with standard 0.250" shell thickness.

Link-Belt® F5000 rolls are ideal for use on high capacity conveyors, severe impact loading areas, and high tension areas of the return belt.

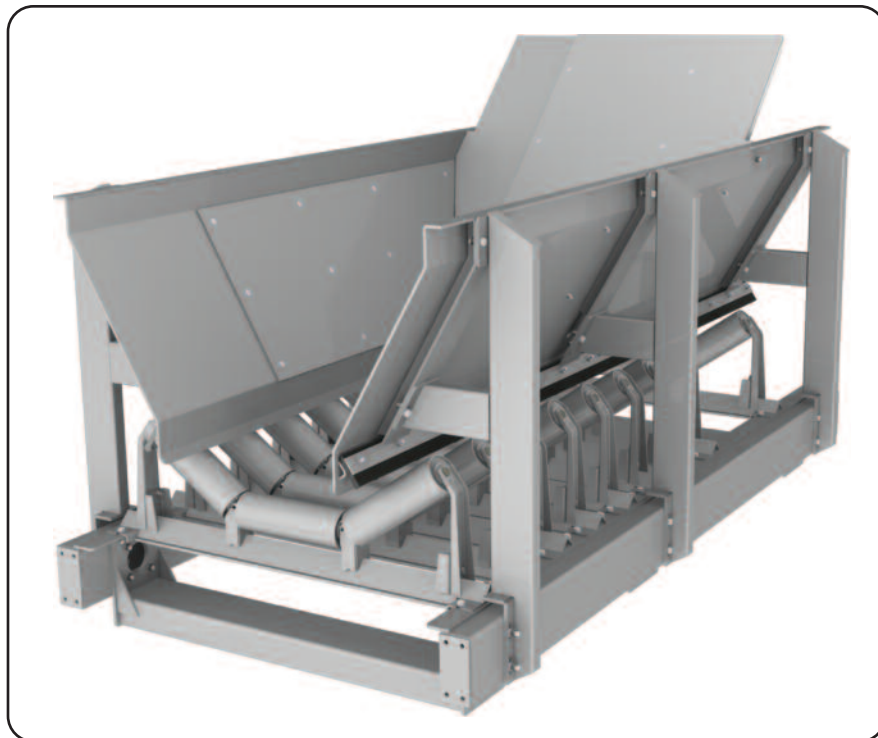

**Underground Loading Section with F5000 Impact Idlers  
3500 tph, 60-inch Belt Width**

# Terminal Equipment

Link-Belt® terminal equipment provides key anchorage points of belt conveyor systems. Syntron Material Handling designs and manufactures a full line of terminal equipment including:

- Discharge sections
- Drives
- Electrical controls
- Belt storage
- Take-ups
- Winches
- Tail sections
- Belt winders
- Loading sections
- Pulleys



Link-Belt terminal equipment is custom designed to meet your specific application requirements. If you are looking for continuous, low maintenance, reliable terminal equipment that will last for the life of the mine, Syntron Material Handling has the solution.

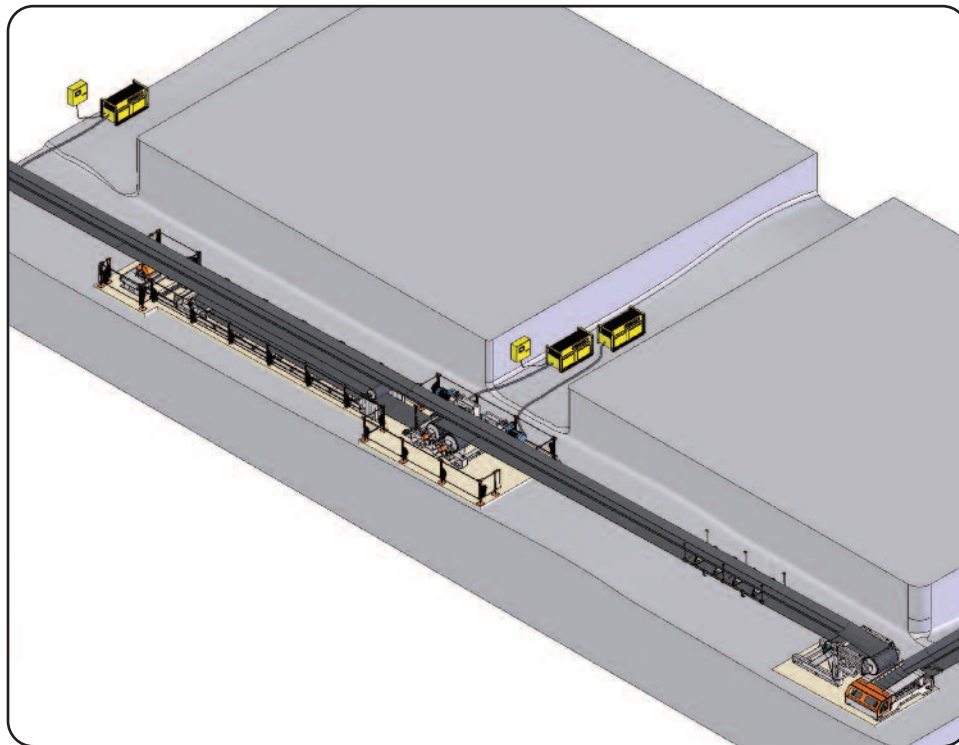



## Discharge and Transfer Sections

Link-Belt® remote discharge units are an integral part of an effective conveying system, providing a discharge or transfer point at the “head end” of the conveyor belt, to another belt, stockpile or bin. Discharge units can be floor or roof mounted and are available in a variety of configurations, from simple one-to-one in-line transfers to complex, multi-belt transfer points. They can also be custom engineered to match any transfer angle - this type of integrated design helps reduce installation time and cost.

Discharge units are equipped with a head pulley to change directions of the conveyor belt as well as to provide a discharge point for the conveyed material on the carry side of the belt. They can also be equipped with a snub pulley to control the elevation of the return belt and to allow for the installation of an integrated belt cleaner system. Discharge units can also be fitted with impact idlers or impact slider beds (in the case of in-line transfers).

Syntron Material Handling has years of experience designing discharge units, with an expansive portfolio of completed designs. Contact us for assistance with your application.



## In-Line Roof-Mounted Transfer

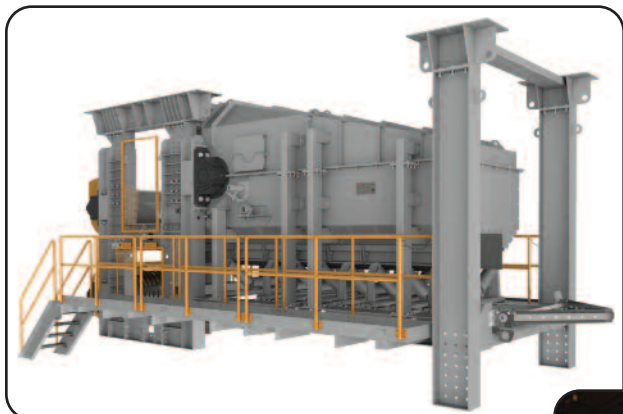

**3-D Engineered Model**



**Final Assembled Product**

# Drives

Link-Belt® drives provide the energy needed to move a loaded conveyor belt throughout the length of the system. Drives consist of pulley skids, power modules and electrical controls. Power modules are modular in construction such that one, two, three or four modules can be attached to the ends of the drive pulleys depending on the total horsepower requirements of the conveyor drive.

Syntron Material Handling provides many types of drive configurations that can be combined with our innovative variable frequency drive (VFD) control systems. Remote conveyor drives keep production moving in permanent installations and feature the latest alignment-free or parallel shaft reducers. Booster drives with load cell feedback systems are used on long conveyors to add power along the length of the conveyor while keeping belt tensions within required parameters. Adjustable boom drives are available to provide portable, compact solutions for low tonnage or temporary installations.

All Link-Belt drive systems are custom engineered. Each component is carefully selected and evaluated to meet specific application requirements. Over the years, we've designed drives and terminal equipment for mines all over the world. Chances are we've already designed a drive system that will meet your requirements. Contact us to discuss your application.

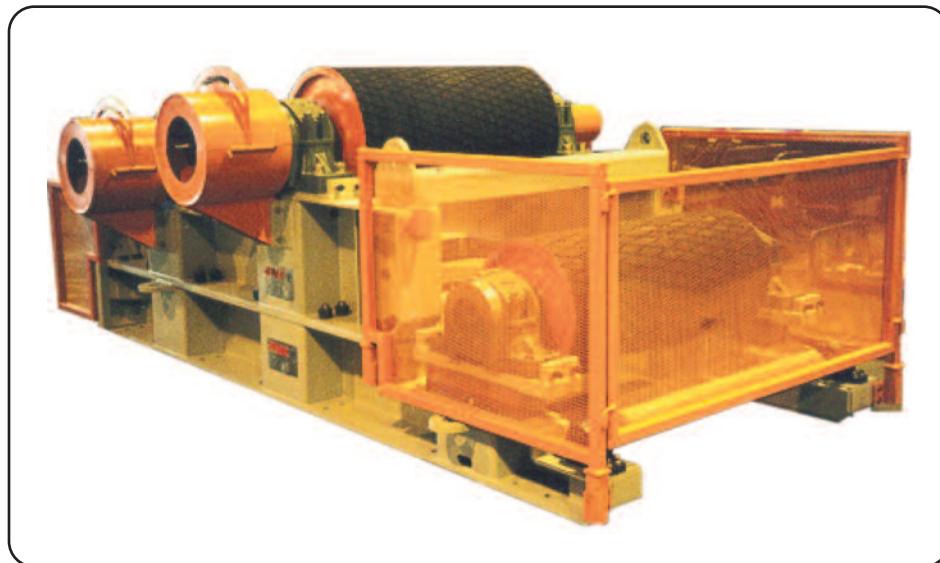

**2-Pulley Alignment-Free Booster Drive**





**2x500HP Alignment Free Drive**

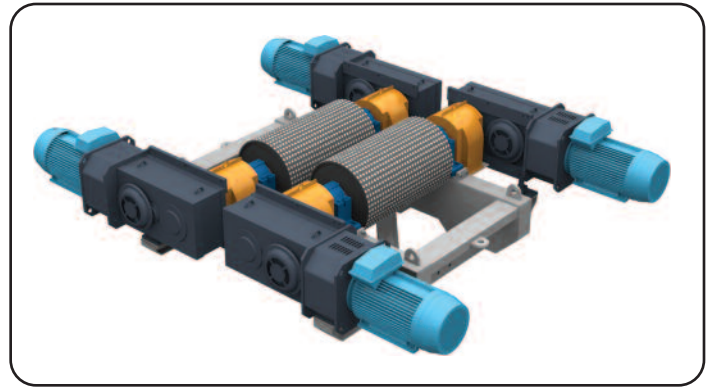

**4x300HP Alignment Free Drive**



**3x500HP Booster/Tripper Drive**

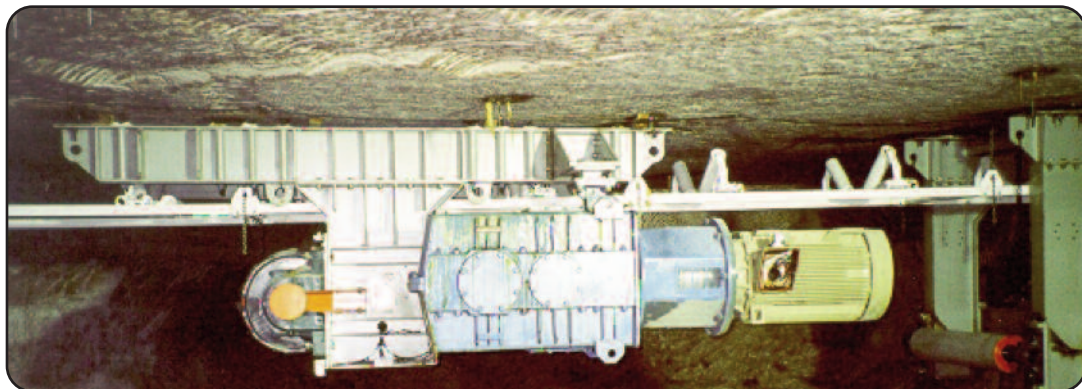

**Roof-Mount 2-Pulley Alignment-Free Drive**



## Loading Sections

Syntron Material Handling provides loading sections in a variety of designs and configurations. Link-Belt® loading sections can be configured for your application and may be fitted to a variety of belt profiles.

All Syntron Material Handling Loading Sections are supplied with Link-Belt impact idlers as standard. High impact slider beds are available as an option. Link-Belt loading sections can be installed and removed from the conveyor system without the need to “break the belt.” This results in increased up time and eliminates the need for expensive and time-consuming belt splicing.

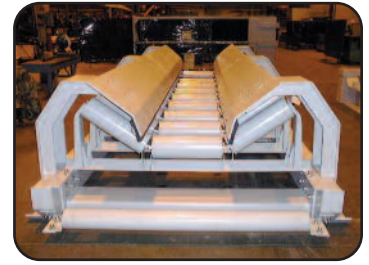

## Tail Sections

The tail section, located at the opposite end from the discharge end of the belt conveyor system, is an essential part of every conveyor system. Link-Belt® tail sections consist of an A-frame tail piece equipped with a pulley mounted onto a frame. Most also have a belt plow mounted to the frame to prevent fugitive material on the return belt from being trapped between the belt and the pulley. The A-frame tail piece must be accompanied by an intermediate loading section.

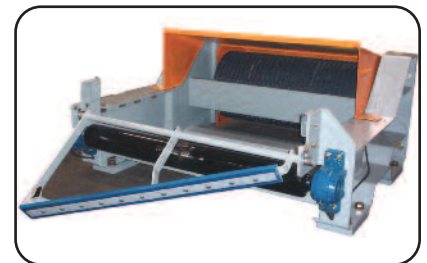

## Tail Loading Sections



A tail loading section has the same features as the tail section plus the addition of an integral loading section.



## Intermediate Loading Sections



Syntron Material Handling offers Link-Belt® intermediate loading sections for all transition angles, with associated chute and skirt arrangements.



# Belt Tensioning

## Link-Belt® Take-Up Units

Link-Belt® Take-Ups provide critical belt tensioning during startup, loading and conveying to prevent drive pulleys from slipping. Take-ups absorb belt stretch while maintaining proper design tension to the belt as the conveyor is unloaded, partially loaded or fully loaded.

Link-Belt Take-Ups are comprised of a modular bolted track system, stationary pulley frame, movable carriage with vee-grooved wheels, and either an AC electric winch or hydraulic cylinder. Hydraulic cylinder take-ups are available in travel distances up to 40 feet, and electric winch take-ups are available in travel distances up to 250 feet.

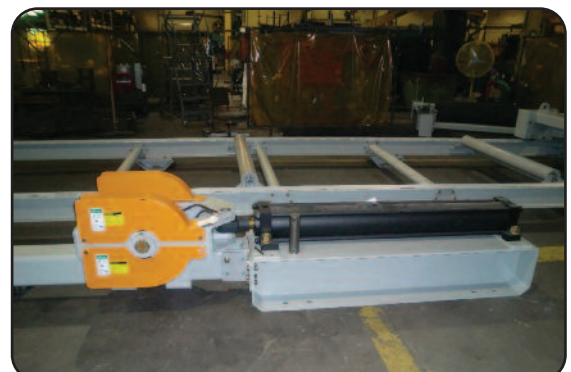
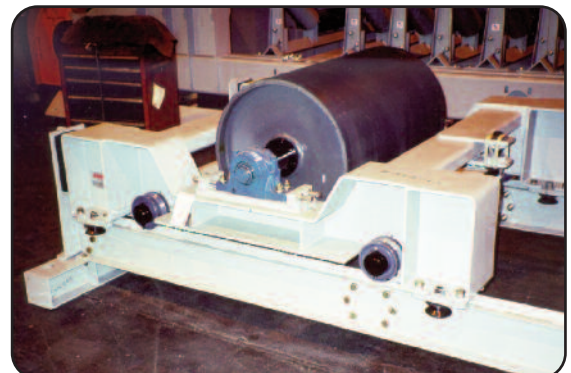

# Belt Storage and Accessories

## Belt Storage Units

Syntron Material Handling offers Link-Belt® belt storage units combined with our electric constant tension winches to provide ample belt storage capacity while maintaining proper belt tension. Single or multiple lap configurations are available. Link-Belt storage units are supplied with positive deploy drop carriages that support the belt at set intervals. Perimeter guarding is available for the full length of the storage unit.

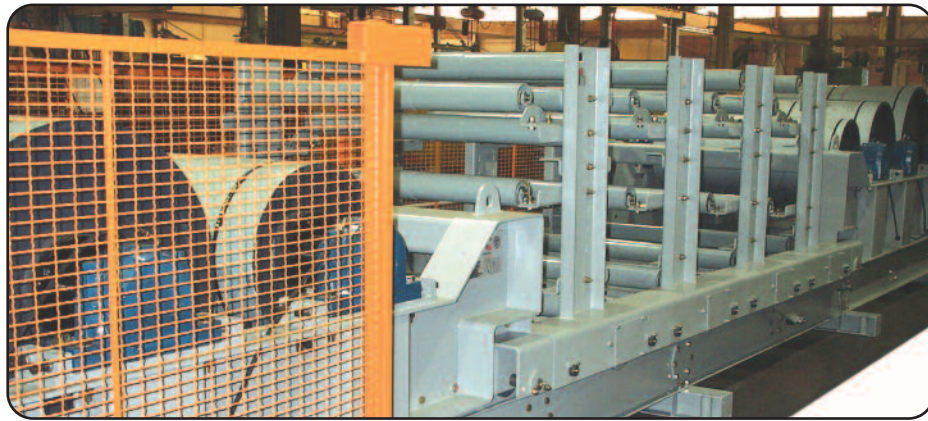
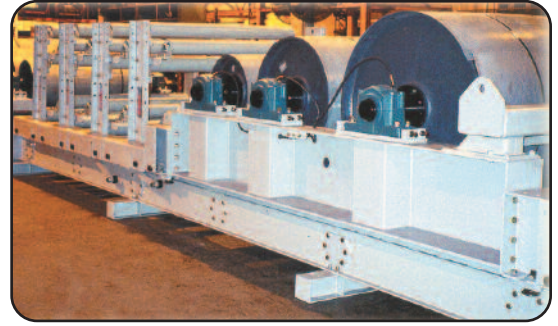

## Belt Winders/Splice Station

Link-Belt® Belt Winders are used to dispense or receive conveyor belting from the belt conveying system. Most often used in conjunction with belt storage units for belt conveyors that are lengthened or shortened on a regular basis, the belt winder reels the conveyor belt into a roll or spool so that it can be moved, stored and reused at a later date.

Belt winders can be mobile or used in conjunction with splice stations where mechanical splices can be installed or removed from a length of conveyor belting located near the belt storage unit.

Belt winders and splice stations are available in any belt width. These systems are designed and manufactured to integrate with your storage units and belt take-ups. Guarding must be used - customized guarding can be supplied by Syntron Material Handling.

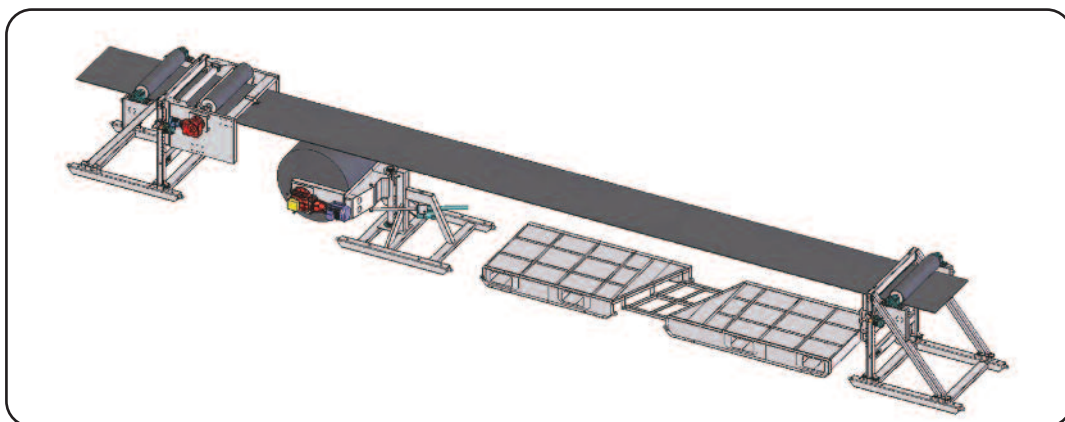



# Electric Winches

Link-Belt® Winches are designed to work in conjunction with our belt storage and take-up units. Winch design incorporates load capacities, line dimensions, and maximum line speed under load. Syntron Material Handling's electric winch provides premier performance while maintaining cost competitiveness. Features include:

- **Active carriage position annunciation (load cell feedback system optional)**
- **Single motor direct drive design**
- **Electric oil shear brake with manual release**
- **Customized control integration with conveyor drive system**
- **Grooved winch drum**

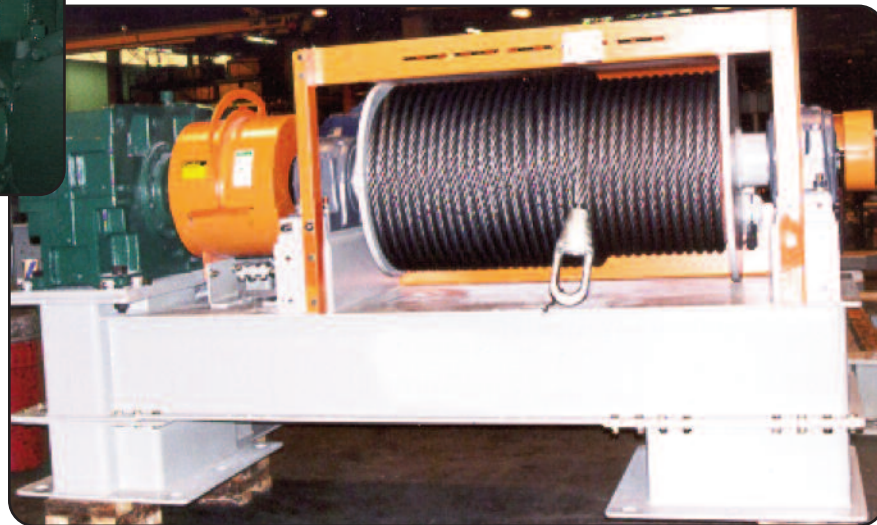
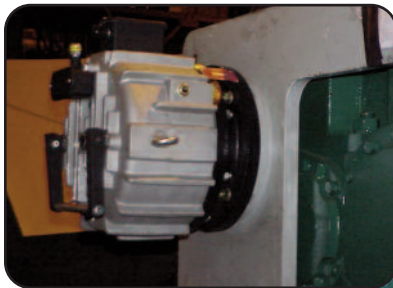
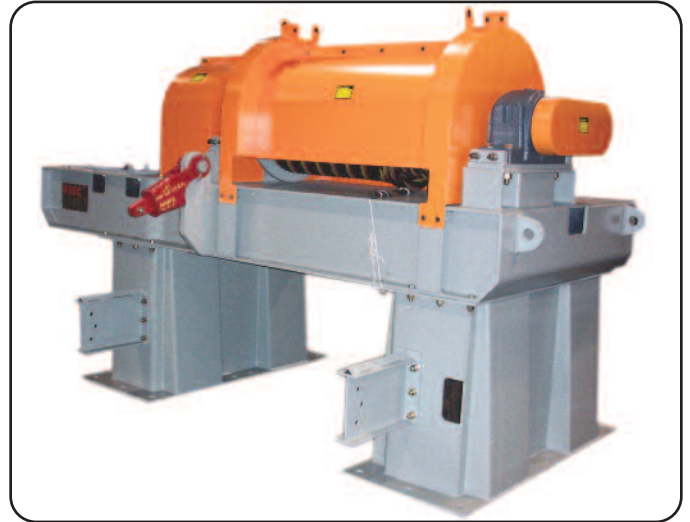

**AC-Constant Tension Winch**  
Note: Availability up to 300 hp.  
Line pull 1,000-100,000 lb.

# Conveyor Control Systems

Because power transmission affects the performance, cost and reliability of conveying systems, Syntron Material Handling pairs Link-Belt® drives with state-of-the-art controls to deliver outstanding control and reliability for starting, running and stopping conveyor belts. Each control system is custom designed to meet specific operating requirements/environments.

Link-Belt controls provide value through technology. Whether the requirements are a simple control system, or a complex automated information system, we'll provide a custom solution to meet your needs.



Conveyor Control products include:

- **VFD Enclosures**
- **Control Panels**
- **Electric Winch Controls**
- **Belt Work Station Controls**
- **Electrocenters**
- **On-site Start-up and Commissioning**



## Features – Standard Products

	VFD Power Unit	Dual VFD Power Unit	Electric Winch VFD Power Unit	Main Control Panel
Few moving parts <i>Reliable</i>	●	●	●	●
Simple design <i>Few parts, reliable, easy to service</i>	●	●	●	●
Fork lift slots <i>Easy to move</i>	●	●	●	
Tapered skid w/chain loops <i>Permits dragging</i>	●	●	●	
Quick engaged door latches <i>Easily opened &amp; closed</i>	●	●	●	●
Push/Pull emergency stop <i>Safety</i>	●	●	●	●
High visibility yellow paint <i>Safety</i>	●	●	●	●
Input/output cable glands <i>Easy, reliable wiring</i>	●	●	●	●
Optional quick connectors <i>Easy to move</i>	●	●	●	●
Serial control <i>Allows complete control and access to all VFD parameters</i>	●	●	●	●
Dust tight enclosure <i>Reduced maintenance</i>	●	●	●	●

**Note:** Other products, including medium voltage VFDs and custom designed skids are available





# Single VFD Power Unit

Syntron Material Handling's **VFD Power Unit** is a VFD package developed to control AC induction motors for mine conveyors and other mine applications. It was the first design of its kind and is now industry standard. Used in conjunction with Syntron Material Handling's **Main Control Panel** (sold separately), the system provides a rugged, feature-rich, low cost solution for applications in harsh mining environments.

## Applications

The **VFD Power Unit** is suitable for:

- Conveyors
- Fans
- Pumps
- Vibratory Feeders
- Screw Conveyors

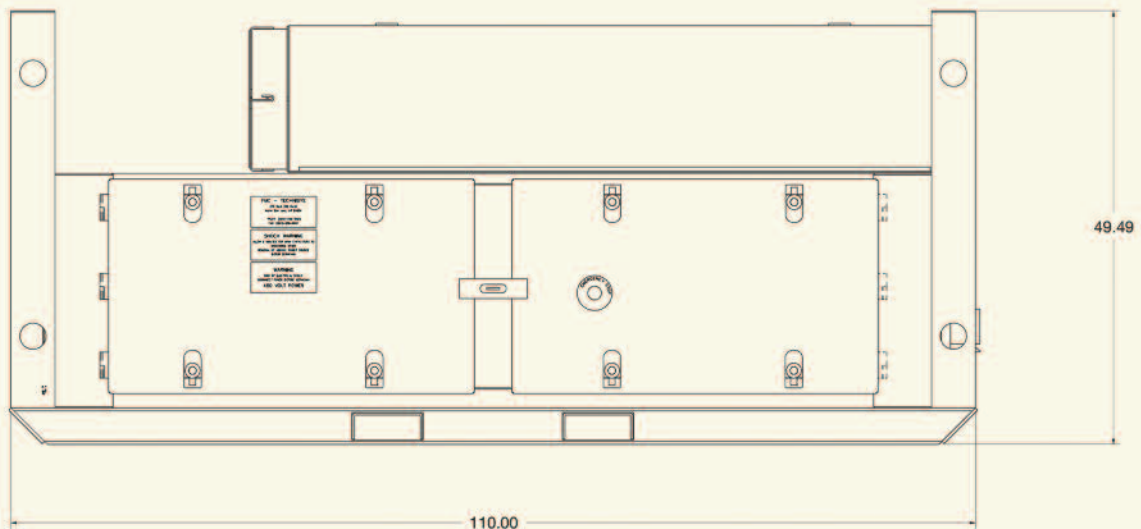
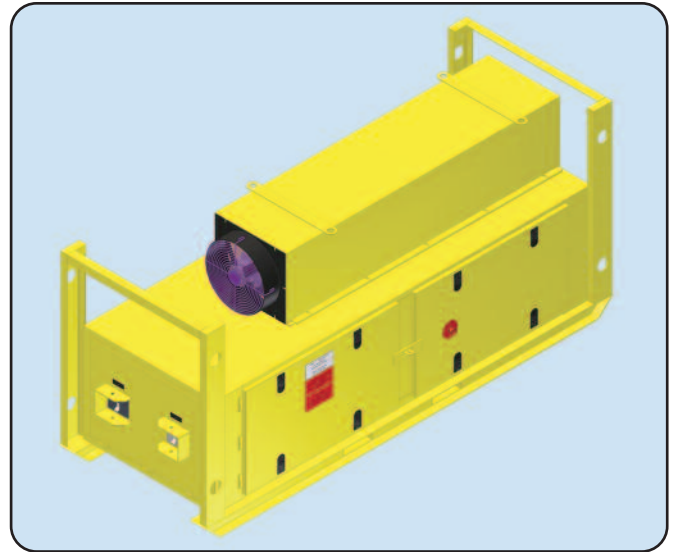

### Overall Dimensions

Wide - 110"  
High - 49.5"  
Deep - 39.5"

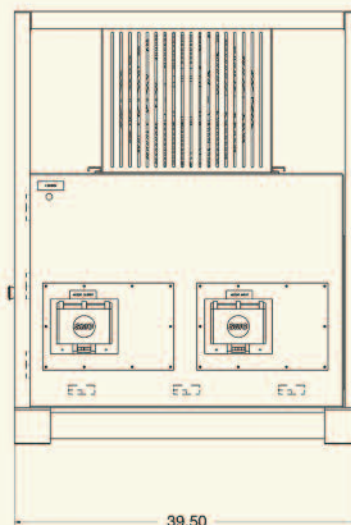



# Dual VFD Power Unit

Syntron Material Handling's **Dual VFD Power Unit** is a VFD package developed to control AC induction motors for mine conveyors and other mine applications. It has two VFDs in one skid to provide independent load-sharing control for two motors. It was the first design of its kind and is now industry standard. The rugged construction will stand up to abuse and the elements in mining environments. Used in conjunction with Syntron Material Handling's **Main Control Panel** (sold separately), the system provides a rugged, feature-rich, low cost solution for applications in harsh mining environments.

## Applications

The **Dual VFD Power Unit** is suitable for:

- Conveyors
- Fans
- Pumps
- Vibratory Feeders
- Screw Conveyors

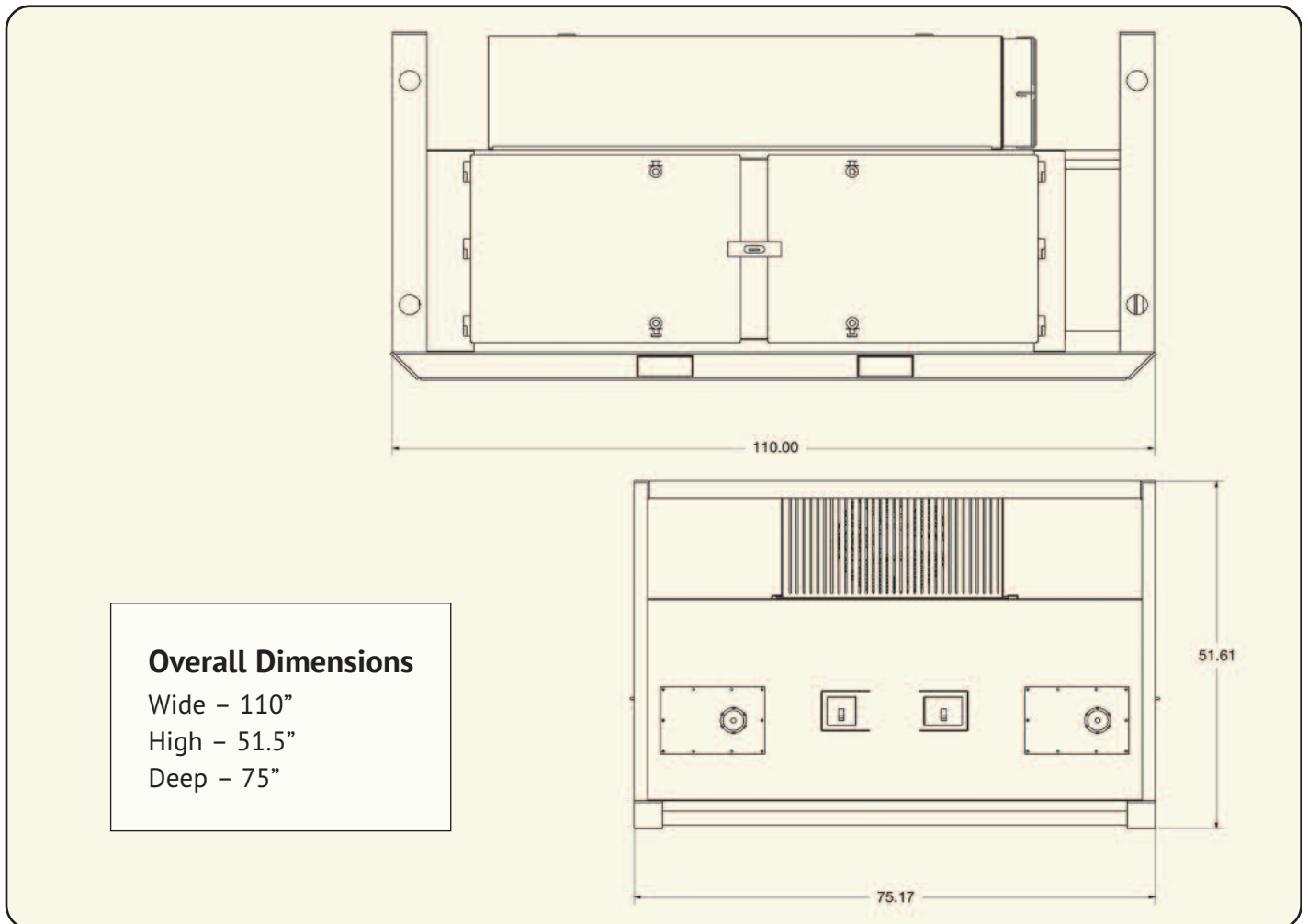
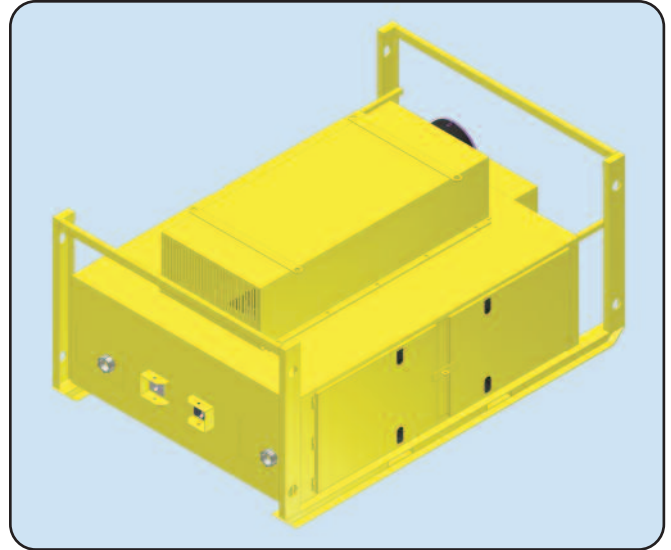

**Overall Dimensions**  
Wide - 110"  
High - 51.5"  
Deep - 75"

# Electric Winch VFD Power Unit

Syntron Material Handling's **Electric Winch VFD Power Unit** is a VFD package developed to control AC induction motors for mine conveyor constant tension winches and other mine applications. It was the first design of its kind and is now industry standard. The rugged construction will stand up to abuse and the elements in mining environments. Syntron Material Handling's **Winch VFD Power Unit** has a built-in control panel with touch screen that provides a rugged, feature-rich, low cost solution for winch applications in harsh mining environments, as well as a dynamic brake resistor, sized to meet customer specifications.

## Applications

The **Electric Winch VFD Power Unit**:

- Is designed specifically for electric constant tension winches
- Can be used for any application that needs dynamic braking capabilities

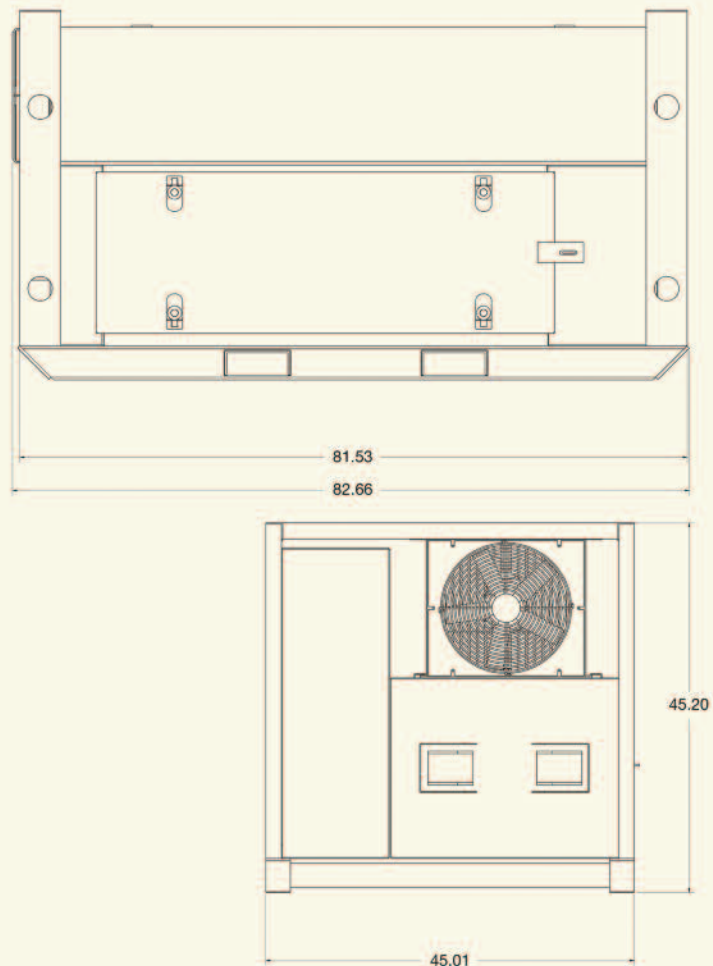
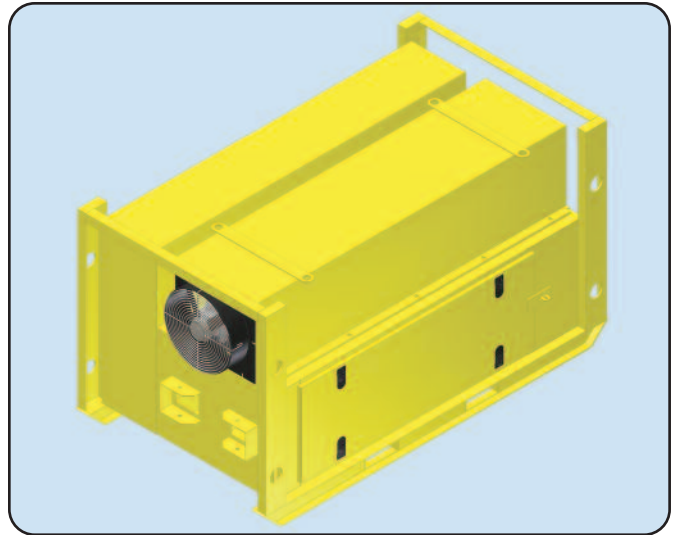

### Overall Dimensions

Wide – 83”  
High – 45”  
Deep – 45”

# Electrocenter

Syntron Material Handling's **Electrocenter** is a turn-key package developed to control AC induction motors and other related equipment. Syntron Material Handling can provide High Voltage Switchgear, High Voltage Pad Mount Supply Transformer, Rack-Mount MCC line ups, VFDs – High Voltage, Medium Voltage, and Low Voltage, PLC-based control, DCS-based control, customer workstations, spare parts storage, etc. Each **Electrocenter** is totally customizable per requirements.

## Applications

The **Electrocenter** is suitable for:

- Process Control Centers
- Over-Land Conveyors
- Main Mine Ventilation Fans
- Pumps
- Remote Control Centers



## Standard Specifications

- Power – 240 to 12,470 VAC, 3 Phase, 50 or 60 Hz
- VFD Horsepower Range – 15 to 10,000 Hp
- 2 man doors with panic bars and 1 access panel
- Interior and exterior lighting, exterior photo-eye
- 460VAC/3Ø HVAC system with thermostat

## Standard Building Specifications

- Base is 3/16" A36 plate formed and welded
- Walls are 14 ga. galv. exterior with 16 ga. galv. interior lining
- Powder coating exterior and interior
- 4" Sloped 14 ga. galv. roof

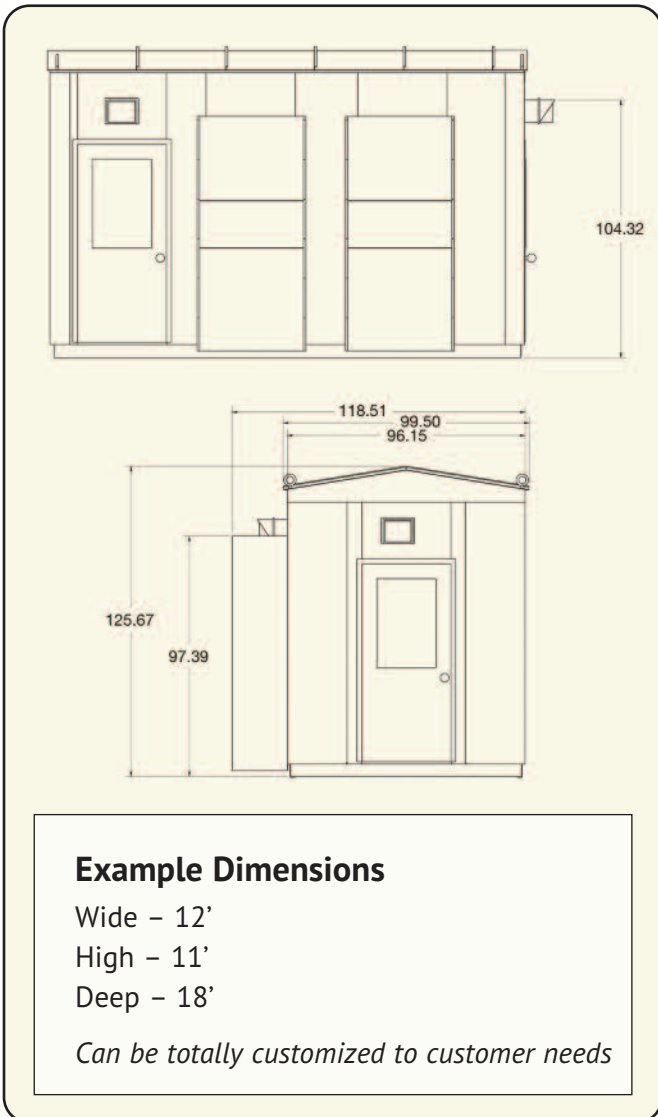

# Main Control Panel

Syntron Material Handling's **Main Control Panel** provides a feature-rich customizable user interface to control up to four VFD Power Units. A large color touch screen is easy to see, understand, and navigate HMI (Human-Machine Interface). All customer safeties and sequences can be monitored with an easily identifiable fault and alarm screen. To aid in troubleshooting, all faults are individually named and logged with a time stamp. The system status screen allows user to monitor metrics such as speed, current, horsepower, incoming line voltage, VFD temperature, etc. A trend screen allows the user to watch real-time plots of system performance data such as torque, speed, current, etc. Password protectable setup screens provide simple regulated write-access to system parameters such as speed and torque limits.



## Applications

The **Main Control Panel** is suitable for:

- Control of any Syntron Material Handling VFD Power Unit

## Specifications

- Customer's choice of processor – most popular being Rockwell Automation's MicroLogix SLC500 series, or ControlLogix
- I/O count and rating is custom-tailored to customer needs; ratings include:
  - Digital Inputs: 24Vdc, 120Vac, or 230Vac
  - Digital Outputs: sinking, sourcing, or relay outputs (available up to 2Amp@230Vac)
  - Analog Inputs:  $\pm 10$ Vdc, 0 – 10Vdc, 4 – 20mA,  $\pm 20$ mA, pulse train, thermocouple
  - Analog Outputs:  $\pm 10$ Vdc, 0 – 10Vdc, 4 – 20mA,  $\pm 20$ mA
- Specialty I/O available
- Optional battery and flash card protected software
- Customer choice of touch-screens and user interface design
- Many fieldbus options available including Controlnet, Profibus and Modbus

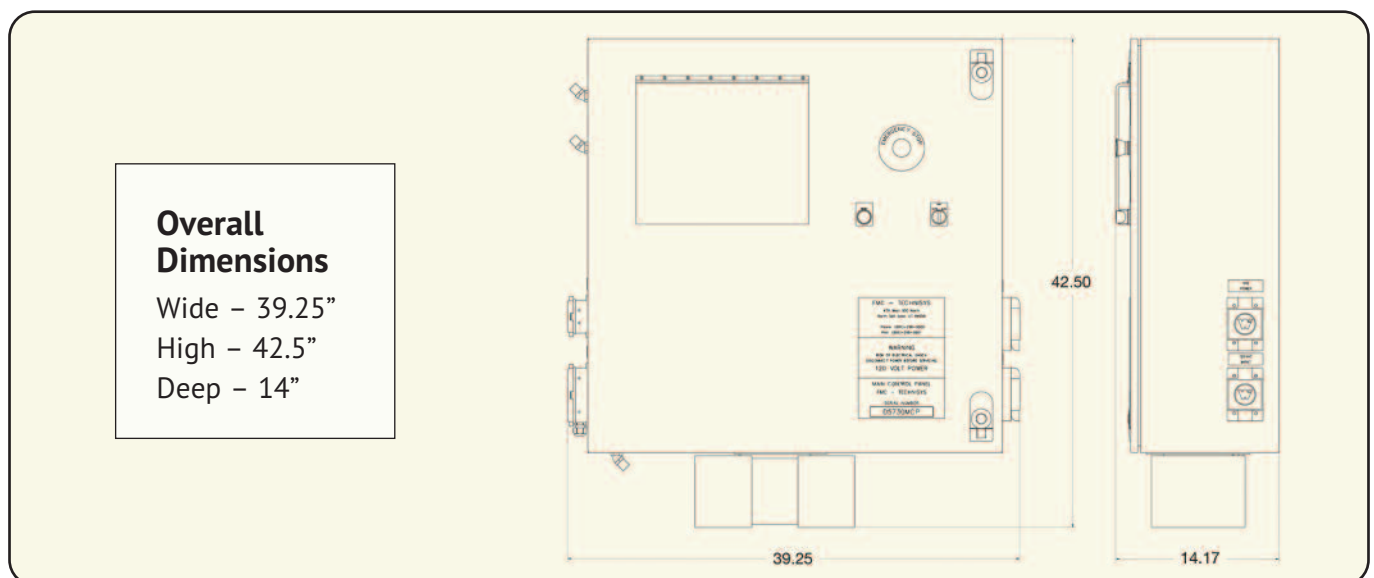



# Economy Control Panel

Syntron Material Handling's **Economy Control Panel** provides a feature-rich customizable user interface to control up to two VFD Power Units. A large color touch screen is easy to see, understand, and navigate HMI (Human-Machine Interface). All customer safeties and sequences can be monitored with an easily identifiable fault and alarm screen. To aid in troubleshooting, all faults are individually named and logged with a time stamp. The system status screen allows user to monitor metrics such as speed, current, horsepower, incoming line voltage, VFD temperature, etc. A trend screen allows the user to watch real-time plots of system performance data such as torque, speed, current, etc. Password protectable setup screens provide simple regulated write-access to system parameters such as speed and torque limits.

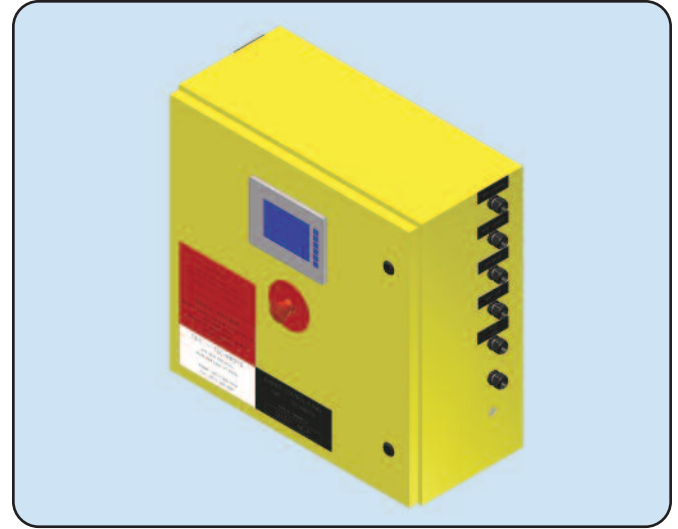

## Applications

The **Economy Control Panel** is suitable for:

- Control of any Syntron Material Handling VFD Power Unit

## Specifications

- Customer's choice of processor – most popular being Rockwell Automation's MicroLogix series processor or Horner APG combination controller touch-screen used for PLC and HMI
- I/O count and rating is custom-tailored to customer needs; ratings include:
  - Digital Inputs: 24Vdc, 120Vac, or 230Vac
  - Digital Outputs: sinking, sourcing, or relay outputs (available up to 2Amp@230Vac)
  - Analog Inputs:  $\pm 10$ Vdc, 0 – 10Vdc, 4 – 20mA,  $\pm 20$ mA, pulse train, thermocouple
  - Analog Outputs:  $\pm 10$ Vdc, 0 – 10Vdc, 4 – 20mA,  $\pm 20$ mA
- Specialty I/O available
- Customer choice of touch-screens and user interface design

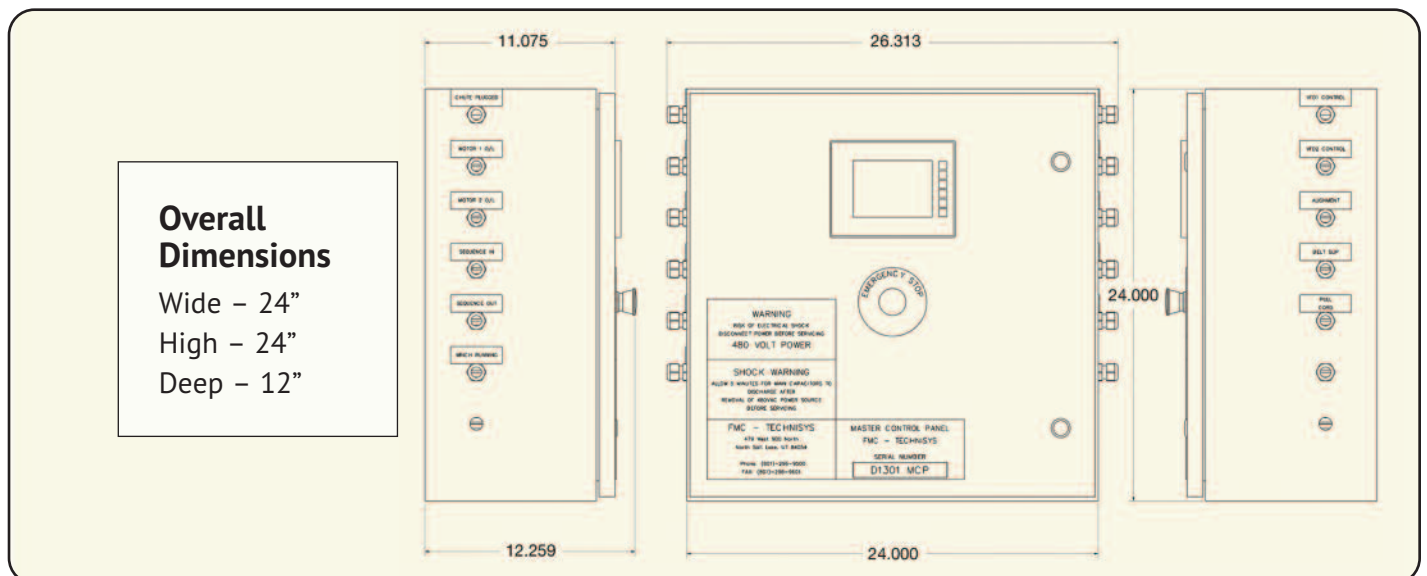





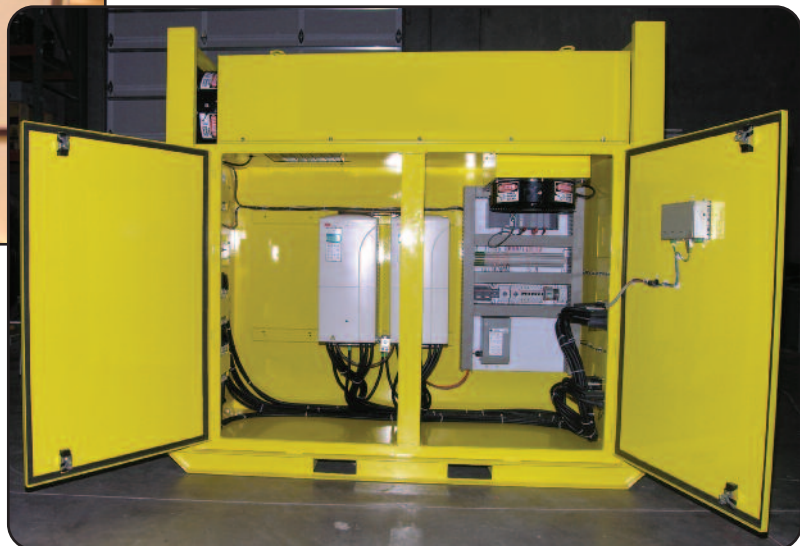



# Syntron Material Handling

## Corporate Office

P.O. Box 1370

Tupelo, Mississippi 38802

Phone: 662.869.5711

Fax: 662.869.7449

## Proven Engineered Products – Complete Material Handling Solutions

**Syntron®**  
**Link-Belt®**

### Saltillo

2730 Hwy 145 South

Saltillo, Mississippi 38866

Phone: 662.869.5711

Fax: 662.869.7493

Toll Free: 800.356.4898

info@syntronmh.com

### Changshu

#2 Road No. 1

Changshu Export Processing Zone

Changshu, Jiangsu, China 215513

Phone: +86 0512.52299002

Fax: +86 0512.52297228

info@syntronmh.com