

**Proven Engineered Products –
Complete Material Handling Solutions
for the Coal Industry**

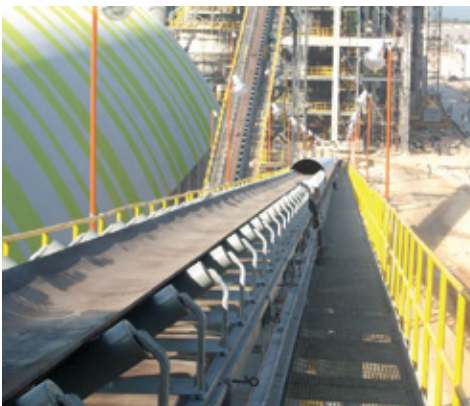



Contents

Underground Solutions

- Drives 4
- Discharge and Transfer Sections 4
- Rigid Belt Structure 6
- Conveyor Control Systems 7
- Syntron® MF Direct-Drive Electromechanical Feeders..... 8

Conveying and Processing

- Link-Belt® Idlers 10
- CEMA Series C2000, D3000 and E4000 Idlers 12

Load-Out Solutions

- CEMA C/D 3000 Truss Frame Idler 14
- Composite Idler Rolls Technical Data 16
- HP High Performance Electromechanical Feeders 17
- Syntron® Electromagnetic Vibrators 18



The World's Best Material Handling Equipment for the Coal Industry

When you're ready to purchase new feeders and idlers – performance, price, quality and dependability certainly impact your decision. Equally important is the name on the Product – Syntron Material Handling. Respected as a Coal Industry leader, Syntron® and Link-Belt® are names you can trust. Always have been.

Our company name is new, however, the Syntron® and Link-Belt® business principles remain the same. Quality. Quality. Quality. Whether built in the early 1900's or today, every Link-Belt® and Syntron® product is truly a labor of love and pride. Syntron Material Handling has the best and most experienced engineers, customer service and manufacturing expertise in the industry. A culture that focuses on innovation, quality manufacturing and excellence in customer service is led by an experienced and forward thinking senior management team.

While management leads the way, the real heartbeat of Syntron Material Handling is a team of employees that have taken idlers, feeders and material handling equipment to new levels of excellence. Many have fine-tuned their skills for more than 20, 30, 40 or even 50 years. Centering our entire operation in Saltillo, MS allows us to maintain the highest Quality Control Standards and on-time deliveries. All our products are produced to OSHA/MSHA standards and ISO Standard 9001:2008. We are happy to boast of being a founder and charter member of CEMA, active members of NSSGA, NMA, SME, FEMA, PTDA, and PMMI. For all your Coal needs contact the leader... Syntron Material Handling. Moving the World with Link-Belt® and Syntron® Brands.



Underground Solutions

Drives

Link-Belt® drives provide the energy needed to move a loaded conveyor belt throughout the length of the system. Drives consist of pulley skids, power modules and electrical controls. Power modules are modular in construction such that one, two, three or four modules can be attached to the ends of the drive pulleys depending on the total horsepower requirements of the conveyor drive.

Syntron Material Handling provides many types of drive configurations that can be combined with our innovative variable frequency drive (VFD) control systems. Remote conveyor drives keep production moving in permanent installations and feature the latest alignment-free or parallel shaft reducers. Booster drives with load cell feedback systems are used on long conveyors to add power along the length of the conveyor while keeping belt tensions within required parameters. Adjustable boom drives are available to provide portable, compact solutions for low tonnage or temporary installations.

All Link-Belt® drive systems are custom engineered. Each component is carefully selected and evaluated to meet specific application requirements. Over the years, we've designed drives and terminal equipment for mines all over the world. Chances are we've already designed a drive system that will meet your requirements. Contact us to discuss your application.

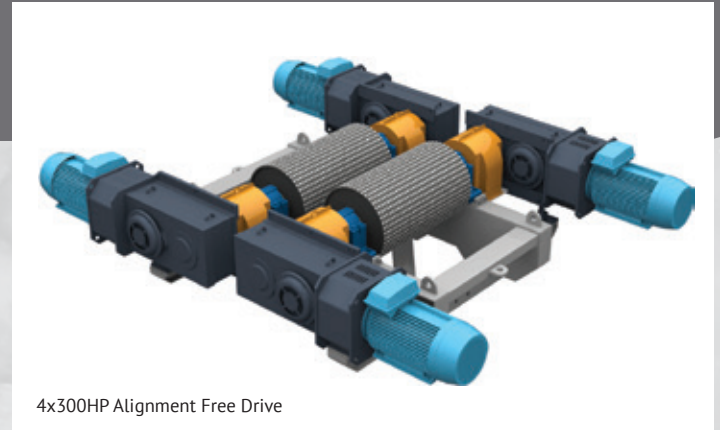

4x300HP Alignment Free Drive

Discharge and Transfer Sections

Link-Belt® remote discharge units are an integral part of an effective conveying system, providing a discharge or transfer point at the “head end” of the conveyor belt, to another belt, stockpile or bin. Discharge units can be floor or roof mounted and are available in a variety of configurations, from simple one-to-one in-line transfers to complex, multi-belt transfer points. They can also be custom engineered to match any transfer angle - this type of integrated design helps reduce installation time and cost.

Discharge units are equipped with a head pulley to change directions of the conveyor belt as well as to provide a discharge point for the conveyed material on the carry side of the belt. They can also be equipped with a snub pulley to control the elevation of the return belt and to allow for the installation of an integrated belt cleaner system. Discharge units can also be fitted with impact idlers or impact slider beds (in the case of in-line transfers).

Syntron Material Handling has years of experience designing discharge units, with an expansive portfolio of completed designs. Contact us for assistance with your application.



Underground Terminal Equipment

- Discharge sections
- Drives
- Electrical controls
- Belt storage
- Take-ups
- Winches
- Tail sections
- Belt winders
- Loading sections
- Pulleys

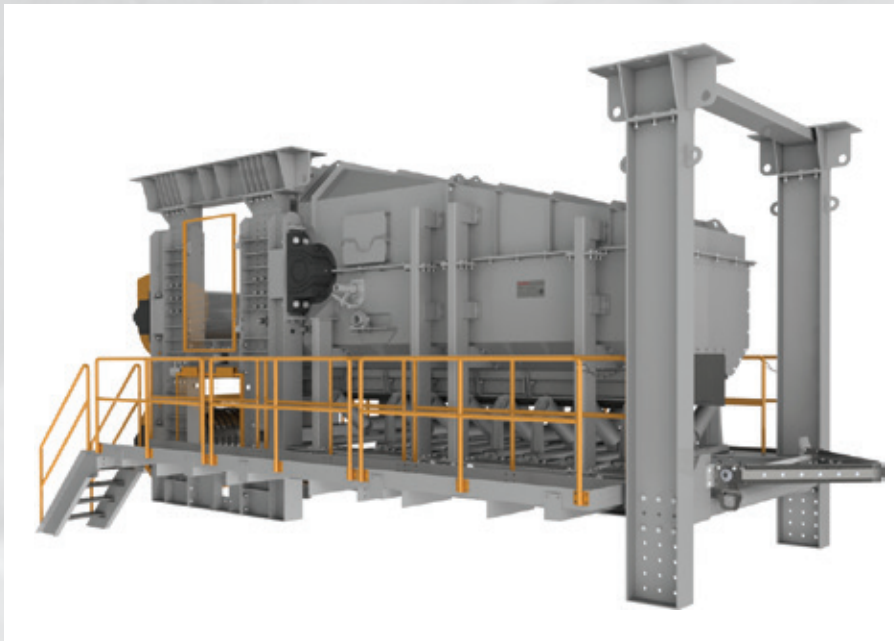

Underground Solutions

Rigid Belt Structure

Larger volumes of tonnage being produced by improved mining techniques created a need for heavier conveyor construction to handle these loads, while maintaining flexibility and short move-up times. Link-Belt® rigid channel construction fulfills these requirements. Rigid stringer construction can be furnished using 3" - 6" channel as required. Both floor mounting and roof mounting are available.

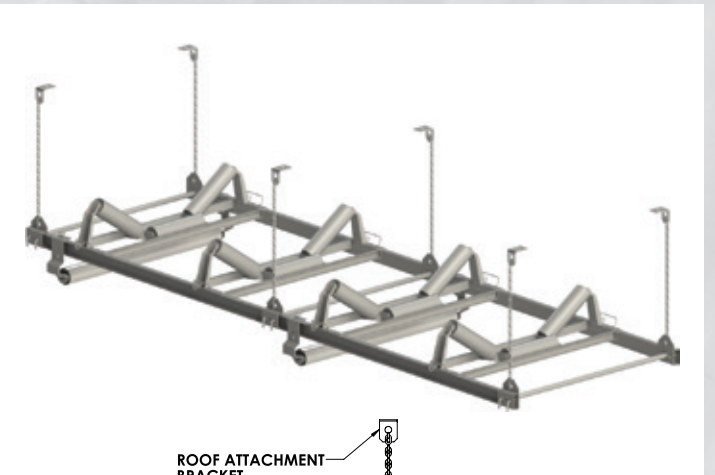

Roof-Hung Rigid Structure

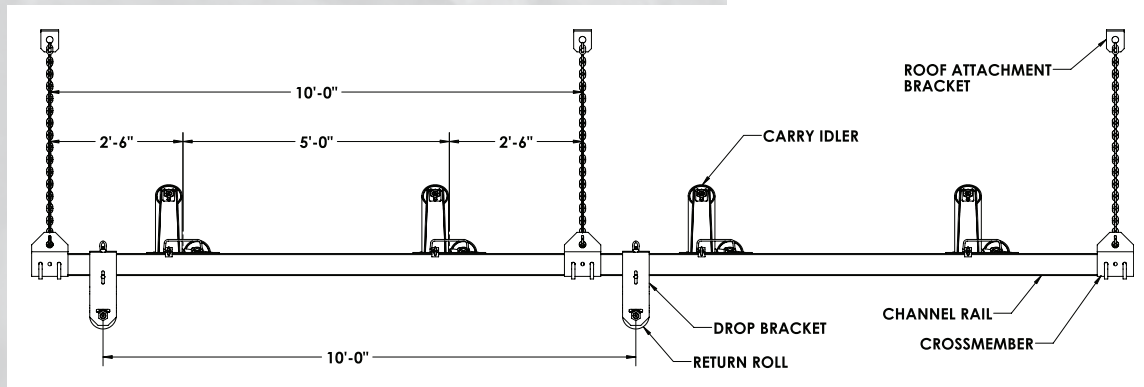

Floor Mounted Rigid Structure

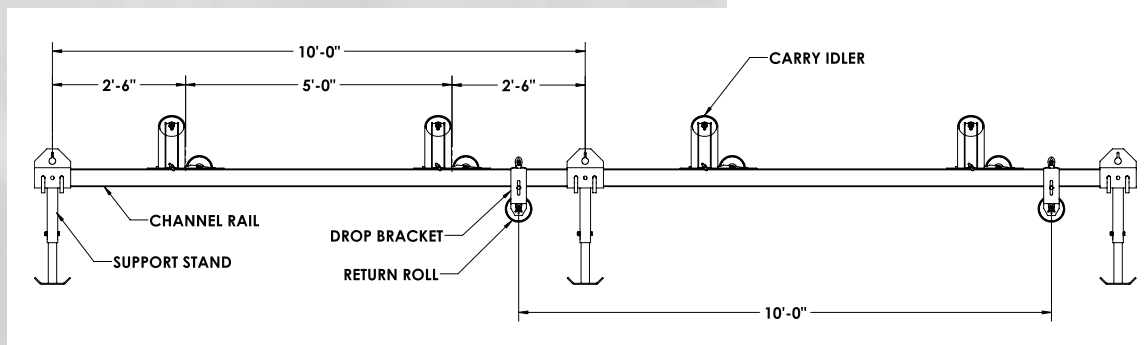

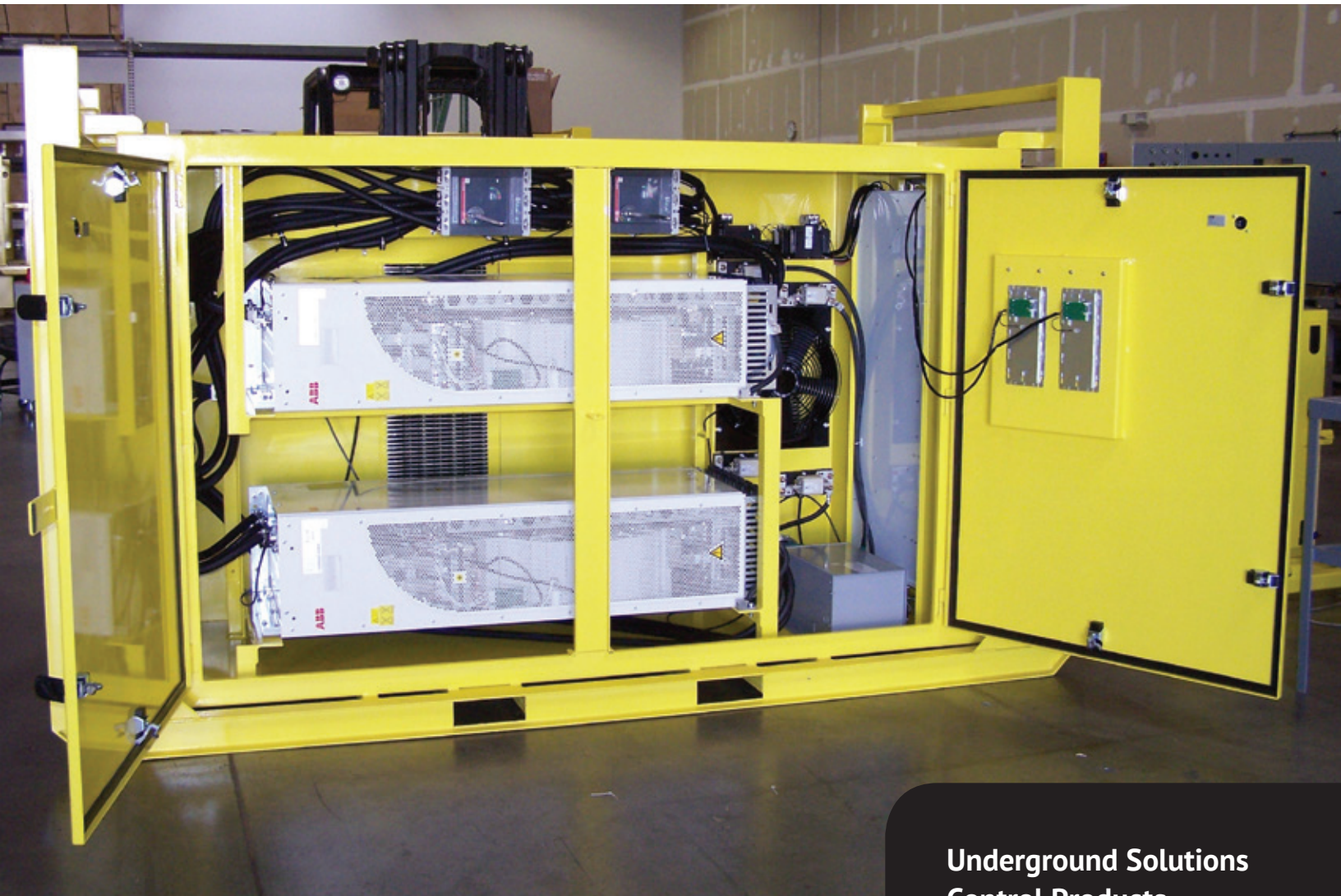

Underground Solutions Control Products

- VFD Enclosures
- Control Panels
- Electric Winch Controls
- Belt Work Station Controls
- Electrocenters
- On-site Start-up and Commissioning

Conveyor Control Systems

Because power transmission affects the performance, cost and reliability of conveying systems, Syntron Material Handling pairs Link-Belt® drives with state-of-the-art controls to deliver outstanding control and reliability for starting, running and stopping conveyor belts. Each control system is custom designed to meet specific operating requirements/environments. Link-Belt® controls provide value through technology. Whether the requirements are a simple control system, or a complex automated information system, we'll provide a custom solution to meet your needs.

Underground Solutions

MF Direct-Drive Electromechanical Feeders

Syntron® MF Direct-Drive Electromechanical Feeders are the heavy-weights of bulk material handling and are used for higher capacity requirements. The ten heavy-duty models handle capacities from 600 to 4,000 tons per hour.*

Syntron® MF Direct-Drive Electromechanical Feeders combine extra structural strength with durable components. The deep wing plates form a bridge between inlet and discharge suspension supports, providing extra strength for years of dependable service. Standard troughs feature unitized weldments – one-piece, completely welded units for greater strength. Troughs are also available with bolt-together construction for tunnel installations or other confined areas.

MF Direct-Drive Electromechanical Feeders are two-mass, spring-connected and sub-resonant-tuned. The exciter unit is connected to the trough with corrosion resistant polymeric springs, which are more stable under varying conditions. The springs are compressed for improved load stability, improved feed angles and straight line motion. The spring design eliminates pinch points, an important safety feature.

All Syntron® MF Direct-Drive Electromechanical Feeder motors are labeled for inverter duty and vibration service. Motors can be supplied to meet UL explosion-proof requirements.

*Based on sand weighing 100 pounds per cubic foot. Capacities vary depending on material characteristics, material density, trough length and width, trough liner type, feeder installation, skirt boards and hopper transitions.



NEW! Two-Mass Direct-Drive

Most Syntron® MF Electromechanical feeders use the new Direct-Drive feature. This drive provides reliable service using a rotary vibrator to minimize components. Belts and pulleys, which commonly require adjustment and replacement due to wear, are eliminated. The new Two-Mass Direct-Drive is also maintenance friendly and requires minimal time for thrust adjustment or replacement.

Syntron® MF Direct-Drive Electromechanical Feeder Features

- Bottom and side access for quick replacement or adjustment
- Polymeric Drive Springs that do not rust or crack due to shock
- Over 80 years of design and engineering expertise and more importantly thousands upon thousands of proven installations
- Suspension / Isolation System with over 40 years of proven performance



Syntron® MF-600 Electromechanical Feeder feeding rock to a crusher.

MF Direct-Drive Electromechanical Feeder Features

- Operating frequency - 1100 VPM at 55.4 Hz
- Stroke: 0.25 - 0.30 inches
- Dependable, flexible, easily adjustable
 - Minimal component design to reduce adjustments and replacements due to wear
 - Quick replacement of Drive Unit
 - Infinite unbalance adjustment
 - VFD control providing 10:1 turn-down feed adjustment
- Sub-resonant tuning
 - Stroke consistency and speed stability under varying headload and material dampening
- Start and operate fully loaded or empty
- Structural strength
 - Deep wing plates
 - Engineered weldments using the latest FEA techniques and software
- Hazardous Area Service
 - Explosion proof motors
 - ULXP:
 - Class 1, Div 1, Group C & D
 - Class 2, Div 1, Group E, F, & G
- Bolt-in trough liners
 - T1-A
 - AR-400, AR-500
 - 304 stainless steel
 - Chromium carbide overlay ceramic
 - UHMW, TIVAR, rubber

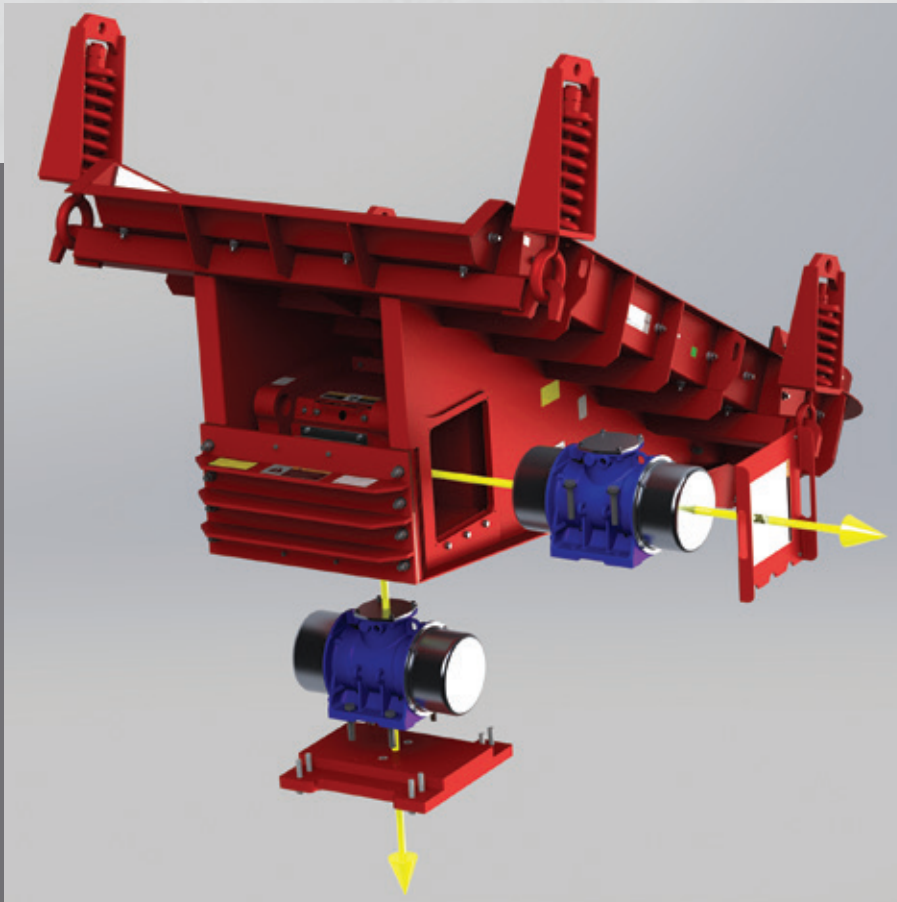

Conveying and Processing

Material Handling Solutions

Our versatile offerings and superior execution reduce operating cost in a variety of material handling industries. Syntron Material Handling has a long history of providing bulk material solutions to industries worldwide. Around the globe, our name is synonymous with problem solving capabilities and material handling expertise.

Link-Belt® Idlers

Syntron Material Handling offers both ball bearing and roller bearing idlers. Our Tupelo facility caters to CEMA standards and produces a wide range of roller bearing idlers as well as medium to light-duty ball bearing rolls. We also provide enhanced idler solutions like our Composite Roll for abrasive and corrosive environments or our Extreme Service Roll used in the Oil Sands industry.

Our Changshu, China facility focuses on metric ball bearing idlers. Our metric idlers are designed around DIN Standards and are performing well in mines, mineral processing and port facility locations around the globe. Both facilities adhere to strict design and quality standards so that idler performance is maximized.

About Our Products

Aboveground and underground idlers, engineered screw conveyors, standard industrial screw conveyor lines and components, bucket elevators, vibrating feeders and screens, and bin vibrators are the principal products manufactured by Syntron Material Handling. Quality and safety are key ingredients in the design and manufacture of Syntron Material Handling's Solutions.

Customer Service

Prompt shipment, on-time delivery, and after-the-sale service are Syntron Material Handling's trademarks. Timely response to your inquiries and reliable delivery and follow through has built our reputation as a service oriented company. Our customer service specialists understand your needs and are experienced in meeting them. Give us a call at **1.800.356.4898**.

In addition to our substantial levels of inventory and replacement parts at our Tupelo facility, we maintain close working relationships with hundreds of authorized stocking distributors located throughout North America and globally to provide strong aftermarket support.





Conveying and Processing

CEMA Series C2000 Idlers

Seal

- Rubber double lip contact seal paired with a polymer deflector with integrated labyrinth seal for robust, redundant sealing capability
- Seal works well in dusty conditions and wash down environments

Roll Thickness

- 5" diameter = 11 ga (0.120)
- 6" diameter = 11 ga (0.120)

Deep Groove Bearings

- Distance from the bearings and shaft ends is minimized to reduce shaft deflection at the bearings. Standard 2RS rubber seals add another level of protection against material and water. C2000 / 6304-2RS / 20mm

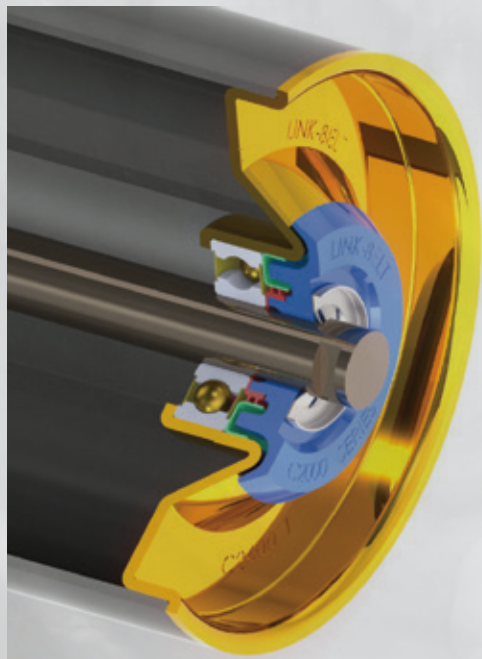

CEMA SERIES C2000 IDLER

CEMA Series D3000 Idlers

Seal

- The outer adjusting nuts are zinc plated, machined steel, to minimize corrosion
- Rubber triple lip contact seal paired with a nylon deflector nut with integrated labyrinth seal for robust, redundant sealing capability
- Seal works well in dusty conditions and wash down environments

Roll Thickness

- 5" diameter = 9 ga (0.148)
- 6" diameter = 8 ga (0.165)
- 4" diameter rolls are available
- 1/4" thick steel rolls are optional

Bearings

- Precision tapered roller bearings with modified geometry; LM11900 with 3/4" bore
- Bearings/shaft are designed to accommodate bearing misalignment under fully rated loads
- L10 bearing life > 60,000 hrs @ 500 rpm, exceeds load ratings of 6306 ball bearing products

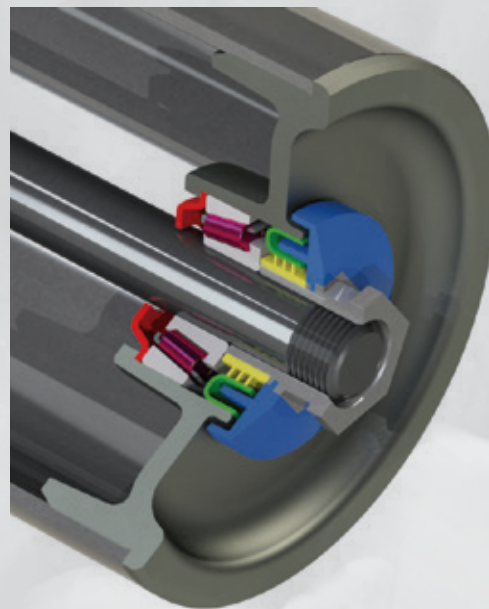

CEMA SERIES D3000 IDLER



CEMA Series E4000 Idlers

Seal

- The outer adjusting nuts are zinc plated, machined steel, to minimize corrosion
- Rubber triple lip contact seal paired with a nylon deflector nut with integrated labyrinth seal for robust, redundant sealing capability
- Seal works well in dusty conditions and wash down environments

Roll Thickness

- 6" diameter = 8 ga (0.165) / 0.250" is available
- 7" diameter = 0.250"

Bearings

- Precision tapered roller bearings with modified geometry; LM67000 with 1-1/4" bore
- Bearings/shaft are designed to accommodate bearing misalignment under fully rated loads
- L10 bearing life > 60,000 hrs @ 500 rpm, exceeds load ratings of 6308 ball bearing products

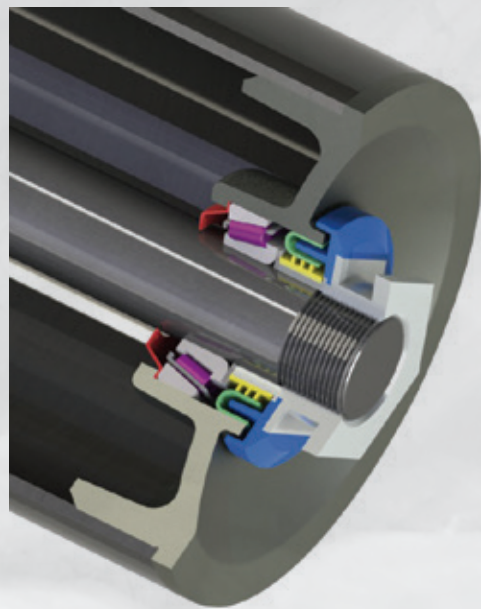

CEMA SERIES E4000 IDLER

Features of CEMA Series C2000, D3000 and E4000 Idlers

Frames

- Inverted angle frame base with slotted foot straps to ensure quick, easy mounting and alignment
- Heavy-duty, die-formed, steel end brackets are contoured for generous clearance to safeguard against spilled materials becoming jammed and impeding the rotation of the rollers
- All idler frames are welded in accordance with AWS D1.1 specifications for structural welds

CEMA

- Idlers meet or exceed CEMA requirements for rugged, continuous material handling
- Multiple belt widths and models available to meet your needs

Coatings

- Frames and rolls are powder-coated
- Assembly hardware is electro-zinc plated

Testing Capabilities

- Load rating
- Seal life
- Roll concentricity
- Roll resistance
- Roll imbalance
- Water resistance

Load-Out Solutions

CEMA C/D 3000 Truss Frame Idler

Syntron Material Handling continues to lead the industry with a commitment to produce the most innovative, specialized belt conveyor equipment available to assist you in solving your unique material handling requirements.

We are very proud of our patented "Link-Belt® Truss Frame Idler" for CEMA D load requirements. Dimensionally interchangeable with all CEMA C/D Series idlers, the Syntron Material Handling Truss Idler features a lightweight frame member that is fabricated from round bar stock to reduce the frame weight by 50%. An added benefit of this truss frame design is a 40% increase in load rating as compared to the conventional CEMA D inverted angle frame. The design of the frame, with rounded surfaces and the lowest roll gap available (0.25 in), ensures against costly material spillage buildup around the idler that may impede production. The Link-Belt® Truss Idler is available in a variety of materials: #304SS, #316SS and of course, carbon steel. This is especially critical in today's markets for the handling of harsh chemicals, phosphate, salt, acids and many other corrosive materials that tend to shorten the life of your equipment. For these caustic applications we complete the offering by placing premium HDPE polyethylene rollers into the stainless steel or carbon steel frame. The polyethylene rollers greatly extend the life of your belt conveyor equipment while reducing costly maintenance and downtime.

Whether your goal is to reduce equipment weight or to extend equipment life subjected to a harsh material handling environment, the Link-Belt® Truss Frame Idler is your ultimate solution.

For additional assistance in selecting the proper Truss Frame Idler to solve your problems, please contact your Syntron Material Handling Customer Service Representative at 1-800-356-4898.

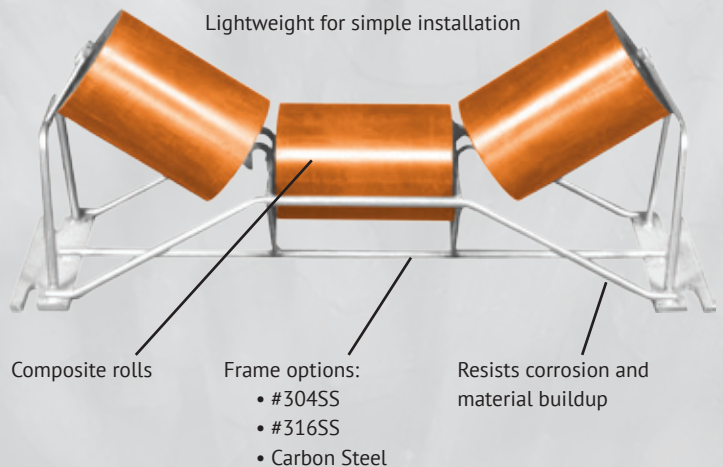



Load Out Features

- Light weight
- Corrosion resistance
- High Speed
- Reliability
- Low noise
- Low vibration

Composite Idler Rolls

- Combats roll degradation typically found in corrosive and abrasive environments
- Longer lasting rolls reduces conveyor downtime
- Lighter weight rolls – “Field Friendly” for maintenance and installation personnel
- Prolongs belt life by reducing material build-up

Load-Out Solutions

Composite Idler Rolls Technical Data

What are Composite Idler Rolls?

- Syntron Material Handling introduces a revolutionary new idler roll made with state-of-the-art glass reinforced polyurethane.
- This tubing is a composite material consisting of layers of high quality glass fabric saturated with a two part thermoset polyurethane resin.
- Syntron Material Handling offers a 5" and a 6" diameter x 1/4" wall tubing size suitable for CEMA C, D and E roll applications (Syntron Material Handling C/D3500, C/D3600 & E4600 Series).
- Roll lengths are available for troughing, return, picking and V-return idlers with belt widths ranging from 18" to 72".
- Polyurethane pultruded composite tubing offers excellent mechanical properties similar to steel and superior to many traditional plastic resin roll products. The recommended operating temperature range is -40°F to +200°F.
- Syntron Material Handling composite rolls are extremely versatile and are suitable for many material handling applications*.
- Standard color: Traditional "Syntron Material Handling Orange"

*Currently not suitable in combustible environments, where possible static charge can cause an explosion hazard.



Features/Benefits

- **Excellent Strength**
Comparable tensile and flexural strength (lengthwise) to steel and aluminum. High strength-to-weight ratio.
- **Lighter Weight**
Material verses material: 75% lighter than steel and 30% lighter than aluminum. Approximately 50% lighter than traditional steel rolls. Easier installation, "Field Friendly" for maintenance and installation personnel, energy savings, and reduced noise.
- **Superior Toughness**
This glass fabric distributes loads to prevent surface damage. No permanent deformities. High impact strength. Crack resistant.
- **High Corrosion Resistance**
Superior resistance to a broad range of chemicals. Excellent in acid, alkali and salt spray environments. Low water absorption. Protective Polyurethane topcoat is suggested if exposed to UV rays during a long term storage.
- **High Abrasion Resistance**
Superior wear resistance to traditional thermoplastic resin rolls, resulting in longer shell life, longer belt life, and less maintenance.
- **Reduced Material Build-Up**
Polyurethane resin resists material build-up on the surface of the roll, thereby prolonging belt life.
- **Low Thermal Coefficient of Expansion**
Low coefficient of thermal expansion, comparable to steel, reducing differential expansion between shell, shaft, and the pressed head.
- **Environmentally Friendly**
Self extinguishing when exposed to flame in a horizontal position. Low carbon footprint compared to thermoplastic rolls. VOC Free.

Is corrosion eating away your profits?

Composite Idler Rolls are Ideal for replacement of steel rolls in corrosive environments.

HP High Performance Electromechanical Feeders

Lowering Project Cost While Boosting Productivity

Built with the Coal Industry in mind, our Syntron® quality products are synonymous with dependability and durability. We continue to listen to your needs and provide technology that is innovative, quality focused, and backed with the Syntron® value you demand and expect. With their robust two-mass, spring connected and sub-resonant tuned features, our feeders provide structural strength and durable components. This combination and the added feature of the deep wing plates forming a bridge between the inlet and discharge suspension supports make our Syntron® product the work horse in coal facilities around the globe.

What's different?

Trough to exciter relationship is key to feeder performance. This new exciter optimizes design fundamentals that are crucial when providing the highest performing feeders in the industry. Our methodology creates improved capacity and higher travel speeds in a more compact area, whereby lowering overall project cost. The exciter is connected to the trough with corrosion resistant polymeric springs, which are more stable under varying conditions. Our springs are compressed for improved load stability, and when combined with optimized motor placement, results in improved feed angles and straight line motion. The exciter is then properly balanced with many different trough options including bolt-together construction for ease of installation in tunnels and other confined areas.



Syntron® Model MF-300 Feeder

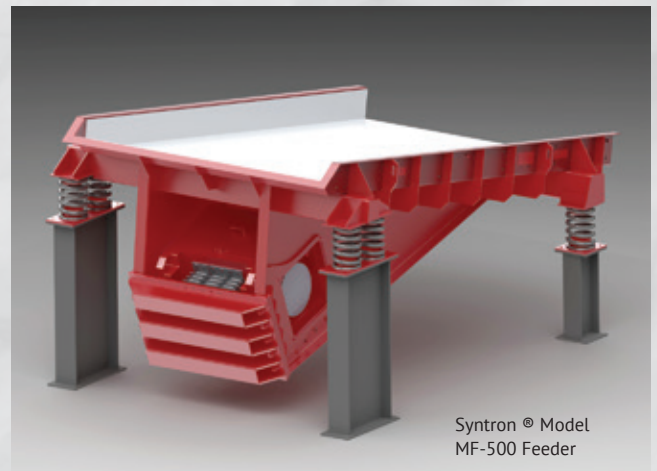

Syntron® Model MF-300 Feeder

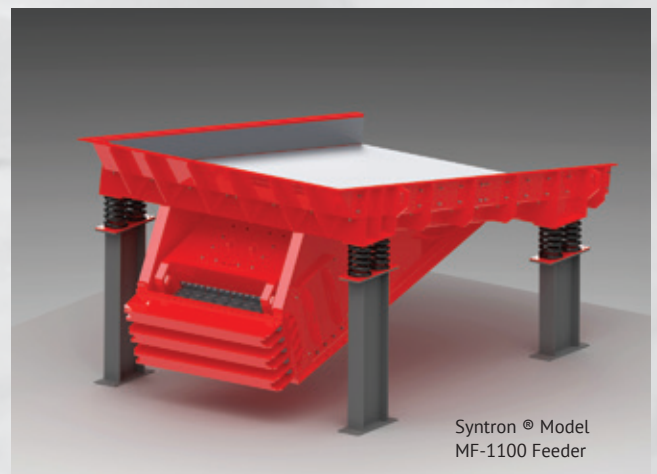

Syntron® Model MF-1100 Feeder

Load-Out Solutions

| Criteria | Syntron Material Handling Capability |
|---------------------------------------|---|
| Relationship | Experienced representatives and distribution global network |
| Engineering expertise & support | 80 years of vibratory manufacturing experience and history of successful installations globally |
| Improved productivity & throughput | High Frequency / Low Stroke |
| Localized vibration | Designed to introduce vibration to localized area, not vibrating support structure |
| Maintenance friendly & lower downtime | No rotating or sliding parts |
| Flexible design | Continuous or intermittent operation |
| Quality & Durability | Syntron® history of manufacturing products with long lifecycles |
| Value-based pricing | High quality products at a competitive price |
| On-time Delivery | Stock Items |
| Timely & Accurate Quotations | 75 Years of Application experience |
| After-market parts and service | In country after market support on 5 continents |

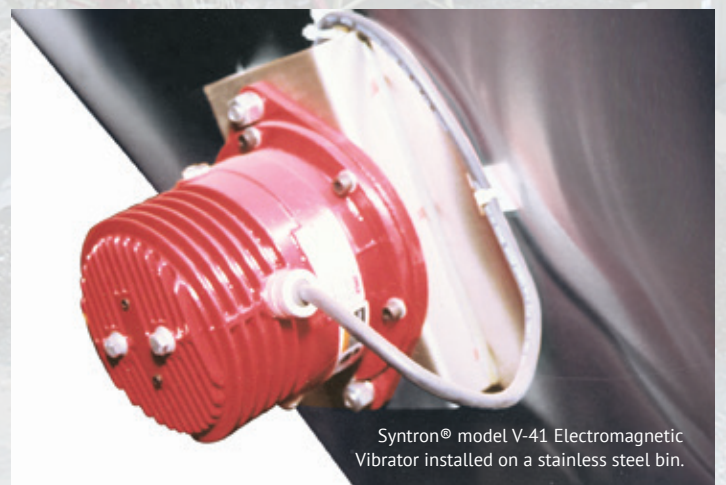
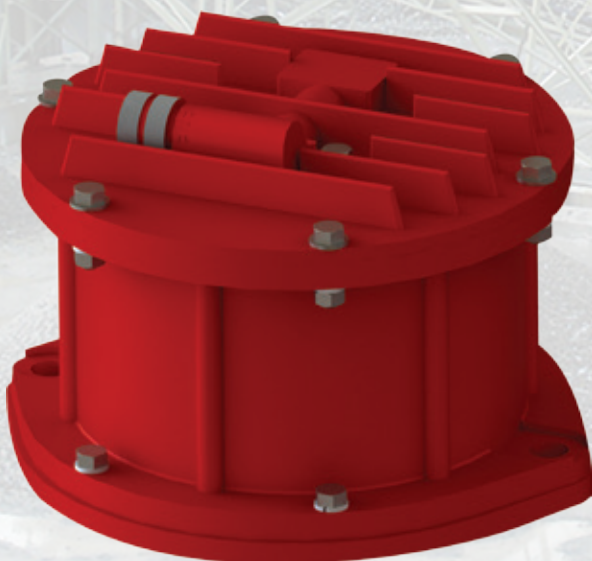



Syntron Material Handling

Proven Engineered Products – Complete Material Handling Solutions

Two powerful industry leading brands—Link-Belt® and Syntron®—have come together under a new company name, Syntron Material Handling, LLC, for one goal – better engineered products.

Established in May 2014, Syntron Material Handling (SMH) was built out of the legacies of Link-Belt® Company and Syntron Company, formerly owned by FMC Technologies. Today, our 300 skilled employees have a combined 4,212 years of industry knowledge that they put into the SMH product every day. We are dedicated to providing customers with complete material handling solutions.

Let Syntron Material Handling's knowledgeable team help your business with conveying, feeding, screening, elevating, vibratory flow aids, and mining controls of bulk product. Whether optimizing existing systems or starting from the ground-up on new and customized plants or mines, our dedicated staff will provide you with the most efficient and cost-effective solutions.

“Our company structure will be very exciting and fast-paced as we charter our new path. The positive attitudes and skills of our employees, the strength of our products, and our long-term customer relationships are our foundation for success.” said CEO Andy Blanchard.

An international leader for innovative solutions, Syntron Material Handling can improve the technology customers are already using. The Link-Belt® expertise and equipment have been instrumental in developing some of the world's largest belt conveyors. The Syntron® feeders are instrumental to supplying energy sources and material handling efforts across the globe.

Levine Leichtman Capital Partners, the new owner of Syntron Material Handling, is committed to the success and growth of the company by investing in engineering capabilities, manufacturing efficiency, and customer service.

Although we may have a new name, we still have the same dedicated employees and industry leading engineered products that make us a market leader.

Syntron Material Handling operates two manufacturing facilities in the USA and China.

All of our products are produced to OSHA/MSHA standards and ISO Standard 9001:2008. We are a charter member of CEMA, and active members of NSSGA, NMA, SME, FEMA, PTDA, and PMMI.



Syntron Material Handling

Corporate Office

P.O. Box 1370

Tupelo, Mississippi 38802

Phone: 662.869.5711

Fax: 662.869.7449

Proven Engineered Products – Complete Material Handling Solutions

Syntron®

Link-Belt®

Saltillo

2730 Hwy 145 South

Saltillo, Mississippi 38866

Phone: 662.869.5711

Fax: 662.869.7493

Toll Free: **800.356.4898**

info@syntronmh.com