

**Link-Belt®  
Belt Conveyor Idlers**



# Contents

## Belt Conveyor Idlers

Syntron Material Handling Proven Engineered Products – Complete Material Handling Solutions .....	3
Series B2000 Idlers .....	6
Replacement Rolls for B2000 .....	25
Series C2000 Idlers .....	28
Replacement Rolls for C2000 .....	46
Series C3000 and D3000 Idlers .....	50
Replacement Rolls for C3000 and D3000 .....	85
Composite Rolls for C3000 and D3000 .....	90
Side Guide Idlers .....	94
Scale Idlers .....	95
Series E4000 Idlers .....	96
Replacement Rolls for E4000 .....	129
Composite Rolls for E4000 .....	132
Series ES Idlers .....	135
Series F5000 Idlers .....	141
Series 40,000 and 70,000 Catenary Idlers .....	147
Catenary Connecting Devices .....	152
Truss Frame Idlers .....	153
Conveyor Belt Alignment .....	154
MHS Powder Coat Painting Process .....	155
Quality Assurance Testing .....	156
Service & Safety Manual Information .....	156



# Syntron Material Handling

## Proven Engineered Products – Complete Material Handling Solutions

Two powerful industry leading brands—**Link-Belt®** and **Syntron®**—have come together under a new company name, Syntron Material Handling, LLC, for one goal – better engineered products.

Established in May 2014, Syntron Material Handling (SMH) was built out of the legacies of Link-Belt Company and Syntron Company, formerly owned by FMC Technologies. Today, our 300 skilled employees have a combined 4,212 years of industry knowledge that they put into the SMH product every day. We are dedicated to providing customers with complete material handling solutions.

Let Syntron Material Handling’s knowledgeable team help your business with conveying, feeding, screening, elevating, vibratory flow aids, and mining controls of bulk product. Whether optimizing existing systems or starting from the ground-up on new and customized plants or mines, our dedicated staff will provide you with the most efficient and cost-effective solutions.

*“Our company structure will be very exciting and fast-paced as we charter our new path. The positive attitudes and skills of our employees, the strength of our products, and our long-term customer relationships are our foundation for success.”* said CEO Andy Blanchard.

An international leader for innovative solutions, Syntron Material Handling can improve the technology customers are already using. The Link-Belt® expertise and equipment have been instrumental in developing some of the world’s largest belt conveyors. The Syntron® feeders are instrumental to supplying energy sources and material handling efforts across the globe.

Levine Leichtman Capital Partners, the new owner of Syntron Material Handling, is committed to the success and growth of the company by investing in engineering capabilities, manufacturing efficiency, and customer service.

Although we may have a new name, we still have the same dedicated employees and industry leading engineered products that make us a market leader.

Syntron Material Handling operates two manufacturing facilities in the USA and China.

All of our products are produced to OSHA/MSHA standards and ISO Standard 9001:2008. We are a charter member of CEMA, and active members of NSSGA, NMA, SME, FEMA, and PMMI.



**Call us today for all your material handling needs.**

**Saltillo**  
2730 Hwy 145 South  
Saltillo, Mississippi 38866  
Phone: 662.869.5711  
Fax: 662.869.7493  
**800.356.4898**  
orders@syntronmh.com

**Changshu**  
#2 Road No. 1  
Changshu Export Processing Zone  
Changshu, Jiangsu, China 215513  
Phone: +86 0512.52299002  
Fax: +86 0512.52297228

## Link-Belt® CEMA Idler Product Offering

Idler Type	CEMA Rating	Bearing Type	Bearing/ Shaft Size	Service Rating
B2000	B	Ball	17 mm	Light to Medium
C2000	C	Ball	20 mm	Medium
C3000	C	TRB	3/4 in	Medium
D3000	D	TRB	3/4 in	Heavy
D7000	D	TRB	3/4 in	Heavy
D2000	D	Ball	30 mm	Heavy
E4000	E	TRB	1 1/4 in	Heavy/Severe
E2000	E	Ball	40 mm	Heavy/Severe
F5000	F	TRB	1 3/4 in	Extreme







# CEMA Series B2000 Idlers

## Frames

- Inverted angle frame base with slotted foot straps to ensure quick, easy mounting and alignment
- Heavy-duty, die-formed, steel end brackets are contoured for generous clearance to safeguard against spilled materials becoming jammed and impeding the rotation of the rollers
- All idler frames are welded in accordance with AWS D1.1 specifications for structural welds

## Seal

- Rubber single lip contact seal paired with a polymer deflector with integrated labyrinth seal for robust, redundant sealing capability
- Seal works well in dusty conditions and wash down environments

## Coatings

- Frames and rolls are powder-coated (see page 155 for details)
- Assembly hardware is electro-zinc plated

## CEMA

- Idlers meet or exceed CEMA requirements for rugged, continuous material handling
- Multiple belt widths and models available to meet your needs

## Roll Thickness

- 4" diameter = 11 ga (0.120)
- 5" diameter = 11 ga (0.120)

## Testing Capabilities

- Load rating
- Seal life
- Roll concentricity
- Roll resistance
- Roll imbalance
- Water resistance

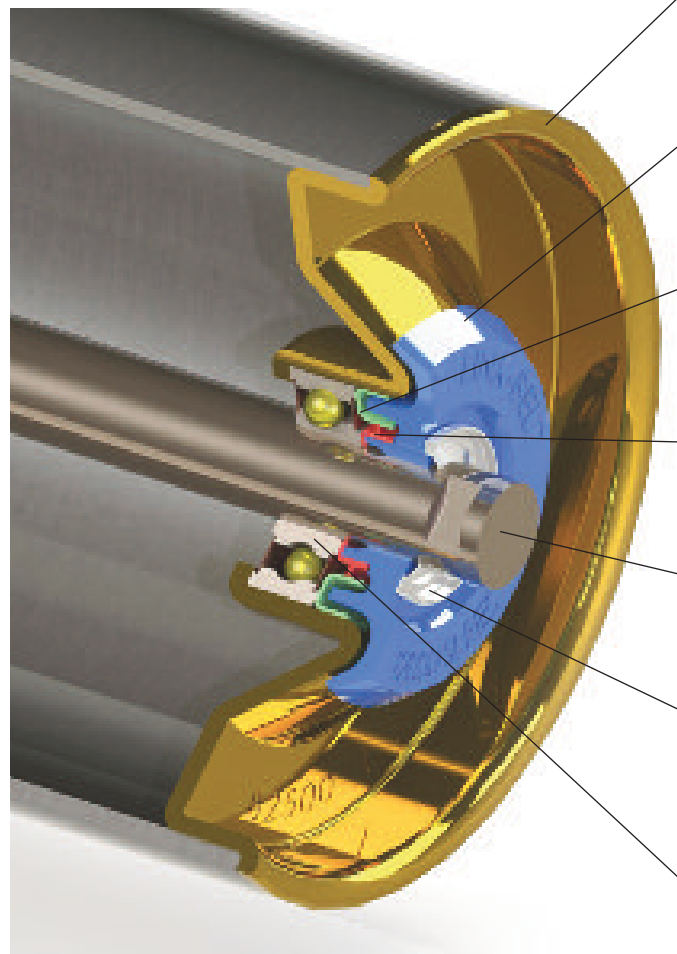

**Pressed Head:** Precision formed pressed head. Designed to provide strength and rigidity while offering reduced weight. Excellent roll concentricity and balance. Yellow Zinc plated for corrosion resistance.

**Deflector:** Impact and corrosion resistant deflector provides first line protection against abrasive materials and washdown water.

**Triple Labyrinth Seal:** Durable, zinc plated inner metal labyrinth seal serves to fling out material and water while providing a smooth, corrosion resistant, heat conductive surface for the contact seal.

**Contact Lip Seal:** Special wear resistant contact seal provides sealing against abrasive fines and washdown water. Suitable for dry, wet, and cold temperature conditions.

**Solid Shaft:** High strength, cold finished low carbon C1018 shafting. Broached shaft end slots anchor the roll assembly securely to the frame.

**Retaining Ring:** Corrosion resistant stainless steel retaining ring eliminates any possible shaft end-play while firmly securing the roll assembly under load.

**Deep Groove Bearings:** Distance from the bearings and shaft ends is minimized to reduce shaft deflection at the bearings. Standard 2RS rubber seals add another level of protection against material and water.

B2000 / 6203-2RS / 17mm

## Carrying Idler Types



**Flat belt idlers** are used for handling bulk materials such as prepared foundry sand and undelinted cotton seed where it is desirable to plow off material at one or more intermediate points along the conveyor. Also used for pulpwood logs, packages, picking and sorting conveyors. Live shaft type is available for heavy duty service.

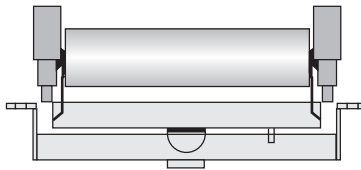

**Flat belt training idlers** automatically train belts and protect belt edges from damage caused by misalignment. Available in the positive action type for belts operating in one direction.

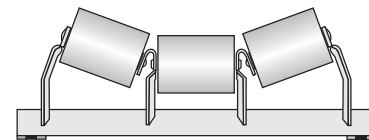

**Troughed belt idlers** for general carrying service are available with roll inclinations of 20°, 35°, and 45°.

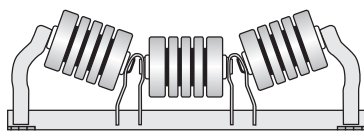

**Troughed belt rubber cushion idlers** protect the belt by absorbing impacts at loading and transfer points. Design features include removable end brackets on 35° and 45° idlers.

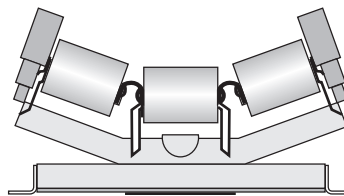

**Troughed belt training idlers** automatically train belts and protect belt edges from damage caused by misalignment. Positive action type available for belts operating in one direction, and actuating shoe type available for two-directional operation (reversing).

## Return Idler Types



**Return belt idlers** carry the empty belt on the return run.

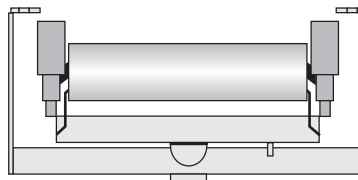

**Return belt training idlers** train the belt and protect its edges from damage caused by misalignment. Positive action type for belts operating in one direction. Actuating shoe type for reversing belts.



**Return belt rubber tread idlers** are used when wet or sticky materials tend to cling to the belt, where corrosion resistance is required or where chemical reaction to iron or steel is involved. Available with urethane treads.

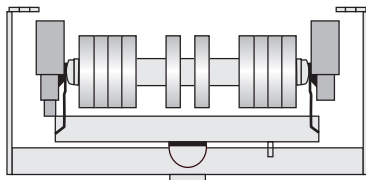

**Return rubber tread training idlers** train the belt and protect its edges from damage caused by misalignment. Used when wet or sticky materials tend to cling to the belt, where corrosion resistance is required or where chemical reaction to iron or steel is involved. Positive action type for belts operating in one direction. Actuating shoe type for reversing belts.





# 20° Troughed Belt Idlers, Equal Length Rolls

steel rolls

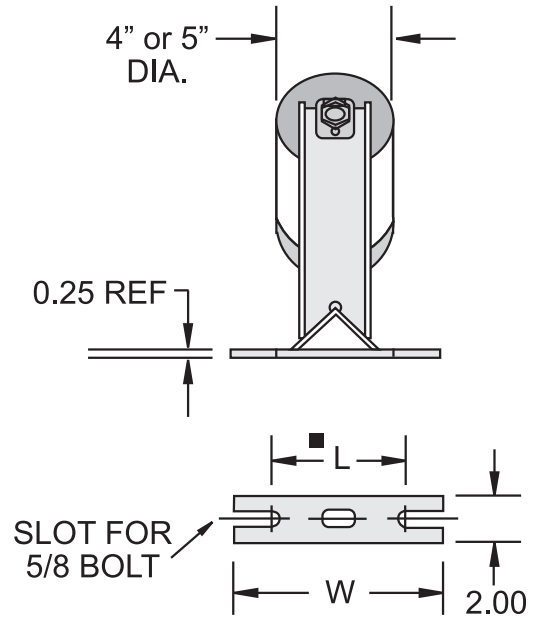
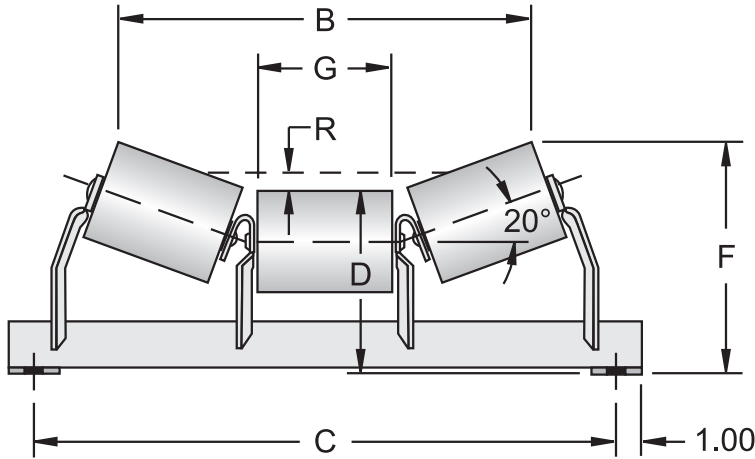

## CEMA B

Belt width, inches	Dia.	Idler number	Idler weight, pounds	B	C	D	F	G	L	R**	W
				Inches							
14	4"	B2401-14	27	16.25	23.00	7.19	9.12	5.25	4.50	0.75	7.50
	5"	B2501-14	30	15.81	23.00	7.69	9.56	5.12	4.50	0.75	7.50
16	4"	B2401-16	29	18.12	25.00	7.19	9.31	5.88	4.50	0.81	7.50
	5"	B2501-16	33	17.62	25.00	7.69	9.75	5.75	4.50	0.81	7.50
18	4"	B2401-18	30	20.25	27.00	7.19	9.56	6.62	4.50	0.94	7.50
	5"	B2501-18	34	19.81	27.00	7.69	10.00	6.50	4.50	0.94	7.50
20	4"	B2401-20	32	22.06	29.00	7.19	9.75	7.25	4.50	1.06	7.50
	5"	B2501-20	37	21.56	29.00	7.69	10.25	7.12	4.50	1.06	7.50
24	4"	B2401-24	35	26.00	33.00	7.19	10.25	8.62	4.50	1.25	7.50
	5"	B2501-24	42	25.56	33.00	7.69	10.69	8.50	4.50	1.25	7.50
30	4"	B2401-30	40	31.81	39.00	7.19	10.94	10.62	4.50	1.62	7.50
	5"	B2501-30	46	31.31	39.00	7.69	11.38	10.50	4.50	1.62	7.50
36	4"	B2401-36	45	37.56	45.00	7.19	11.62	12.62	4.50	1.94	7.50
	5"	B2501-36	53	37.06	45.00	7.69	12.06	12.50	4.50	1.94	7.50
42	4"	B2401-42	50	43.31	51.00	7.19	12.31	14.62	4.50	2.31	7.50
	5"	B2501-42	59	42.81	51.00	7.69	12.75	14.50	4.50	2.31	7.50

\*\* To top of discharge or bend pulleys, except tail pulley.

■ 6" bolt spacing recommended to permit adjustment.



# 20° Troughed Belt Idlers, Equal Length Rolls

rubber cushion rolls (impact)

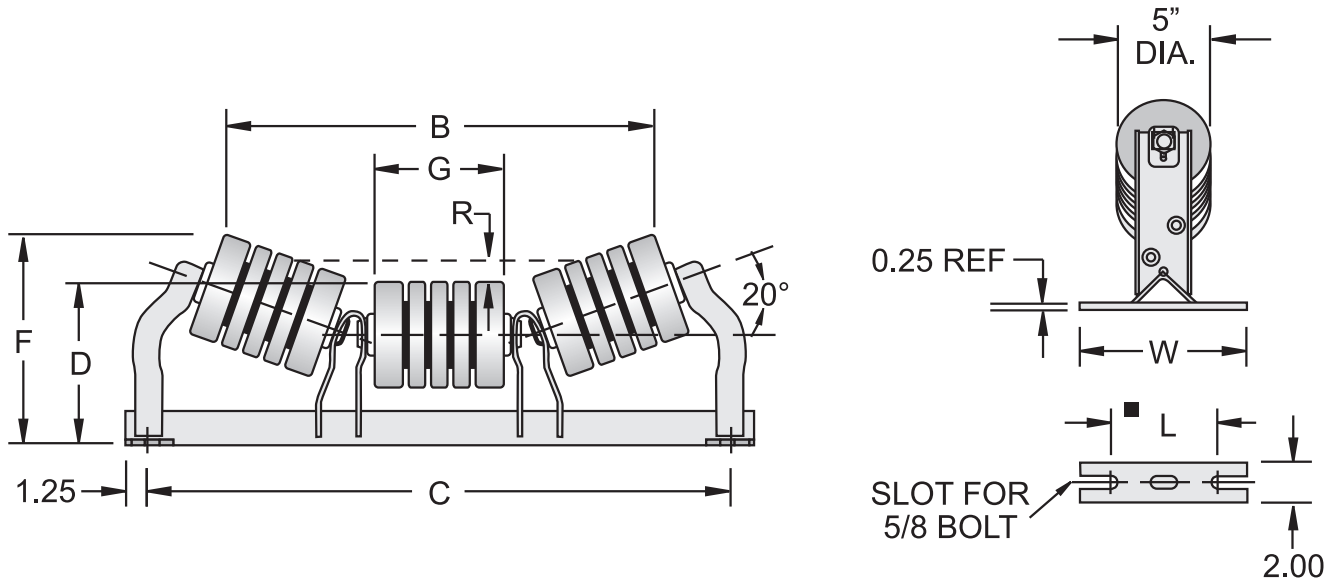

## CEMA B

Belt width, inches	Dia.	Idler number	Idler weight, pounds	B	C	D	F	G	L	R**	W
				Inches							
18	5"	B2504-18	43	19.88	27.00	7.69	9.94	6.06	4.50	0.88	7.50
20	5"	B2504-20	47	22.00	29.00	7.69	10.19	6.81	4.50	1.00	7.50
24	5"	B2504-24	52	26.00	33.00	7.69	10.69	8.19	4.50	1.25	7.50
30	5"	B2504-30	61	31.88	39.00	7.69	11.44	10.19	4.50	1.62	7.50
36	5"	B2504-36	71	37.62	45.00	7.69	12.06	12.19	4.50	1.94	7.50
42	5"	B2504-42	91	44.25	51.00	7.69	12.81	14.50	4.50	2.19	7.50

\*\* To top of discharge or bend pulleys, except tail pulley.

■ 6" bolt spacing recommended to permit adjustment.

# 20° Troughed Belt Training Idlers, Equal Length Rolls

**positive action type**

(above deck mounting)

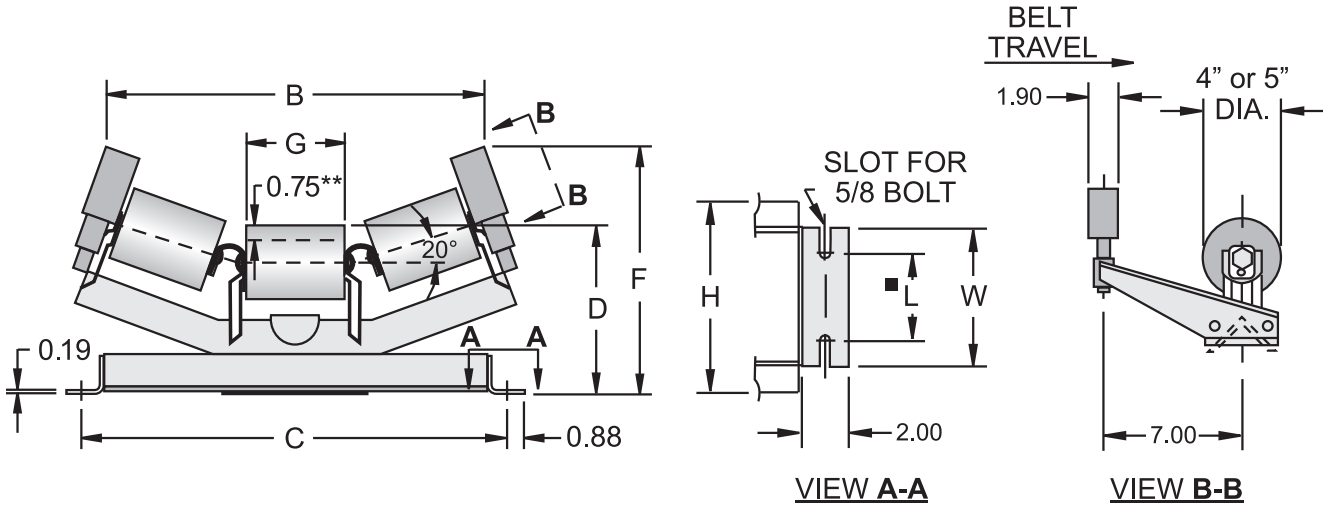

## CEMA B

Belt width, inches	Dia.	Idler number	Idler weight, pounds	B	C	D	F	G	L	W	H
				Inches							
14	4"	B2407-14	71	18.94	23.00	7.88	12.50	5.25	4.50	8.00	11.75
	5"	B2507-14	75	18.94	23.00	8.38	12.50	5.12	4.50	8.00	11.75
16	4"	B2407-16	77	20.75	25.00	7.88	12.69	5.88	4.50	8.00	11.75
	5"	B2507-16	81	20.75	25.00	8.38	12.69	5.75	4.50	8.00	11.75
18	4"	B2407-18	81	22.88	27.00	7.88	13.00	6.62	4.50	8.00	11.75
	5"	B2507-18	85	22.88	27.00	8.38	13.00	6.50	4.50	8.00	11.75
20	4"	B2407-20	87	24.69	29.00	7.88	13.19	7.25	4.50	8.00	11.75
	5"	B2507-20	91	24.69	29.00	8.38	13.19	7.12	4.50	8.00	11.75
24	4"	B2407-24	92	28.62	33.00	7.88	13.62	8.62	4.50	8.00	11.75
	5"	B2507-24	97	28.62	33.00	8.38	13.62	8.50	4.50	8.00	11.75
30	4"	B2407-30	108	34.38	39.00	7.88	14.31	10.62	4.50	8.00	11.75
	5"	B2507-30	113	34.38	39.00	8.38	14.31	10.50	4.50	8.00	11.75
36	4"	B2407-36	122	40.12	45.00	7.88	15.00	12.62	4.50	8.00	11.75
	5"	B2507-36	120	40.12	45.00	8.38	15.00	12.50	4.50	8.00	11.75
42	4"	B2407-42	143	45.94	51.00	7.88	15.69	14.62	4.50	8.00	11.75
	5"	B2507-42	150	45.94	51.00	8.38	15.69	14.50	4.50	8.00	11.75

\*\* Elevation above adjacent idlers.

■ 6" bolt spacing recommended to permit adjustment.

# 35° Troughed Belt Idlers, Equal Length Rolls

steel rolls

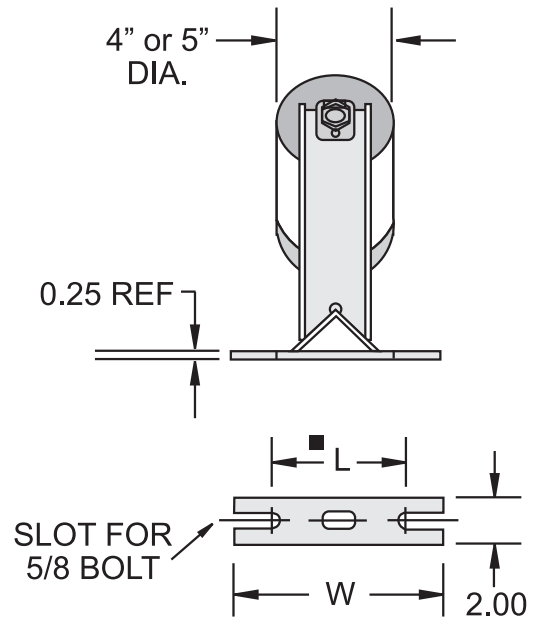
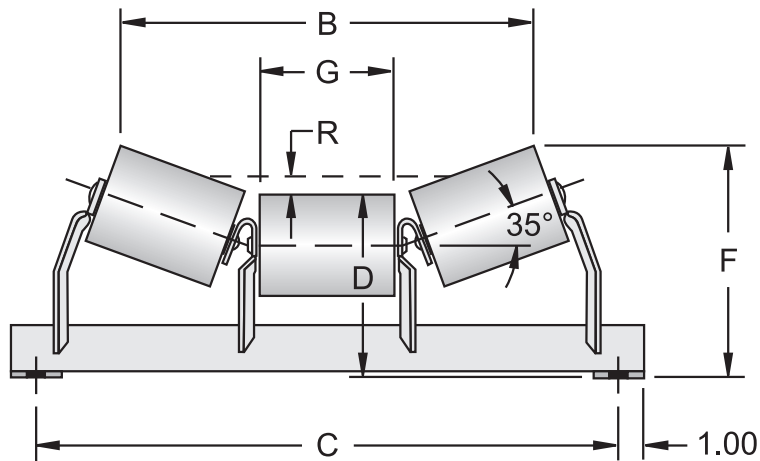

## CEMA B

Belt width, inches	Dia.	Idler number	Idler weight, pounds	B	C	D	F	G	L	R**	W
				Inches							
14	4"	B2428-14	27	14.94	23.00	7.19	10.38	5.25	4.50	1.19	7.50
	5"	B2528-14	31	14.31	23.00	7.69	10.75	5.12	4.50	1.19	7.50
16	4"	B2428-16	30	16.62	25.00	7.19	10.75	5.88	4.50	1.38	7.50
	5"	B2528-16	33	16.00	25.00	7.69	11.12	5.75	4.50	1.38	7.50
18	4"	B2428-18	31	18.56	27.00	7.19	11.19	6.62	4.50	1.56	7.50
	5"	B2528-18	35	17.94	27.00	7.69	11.56	6.50	4.50	1.56	7.50
20	4"	B2428-20	33	20.25	29.00	7.19	11.56	7.25	4.50	1.75	7.50
	5"	B2528-20	37	19.62	29.00	7.69	11.94	7.12	4.50	1.75	7.50
24	4"	B2428-24	36	23.88	33.00	7.19	12.31	8.62	4.50	2.12	7.50
	5"	B2528-24	40	23.25	33.00	7.69	12.69	8.50	4.50	2.12	7.50
30	4"	B2428-30	41	29.12	39.00	7.19	13.50	10.62	4.50	2.75	7.50
	5"	B2528-30	47	28.50	39.00	7.69	13.88	10.50	4.50	2.75	7.50
36	4"	B2428-36	46	34.38	45.00	7.19	14.62	12.62	4.50	3.31	7.50
	5"	B2528-36	52	33.81	45.00	7.69	15.00	12.50	4.50	3.31	7.50
42	4"	B2428-42	52	38.88	51.00	7.19	15.75	14.62	4.50	3.88	7.50
	5"	B2528-42	54	39.06	51.00	7.69	16.12	14.50	4.50	3.88	7.50

\*\* To top of discharge or bend pulleys, except tail pulley.

■ 6" bolt spacing recommended to permit adjustment.

# 35° Troughed Belt Idlers, Equal Length Rolls

rubber cushion rolls (impact)

(demountable end brackets)

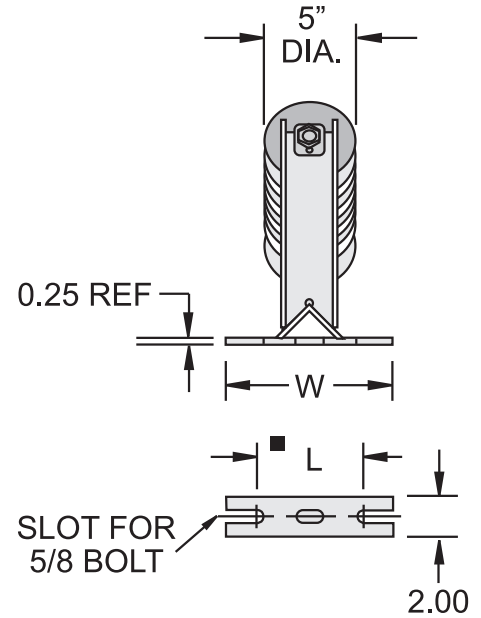
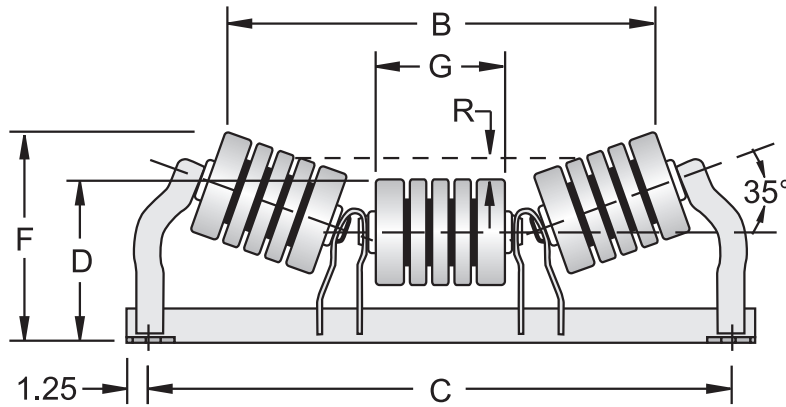

## CEMA B

Belt width, inches	Dia.	Idler number	Idler weight, pounds	B	C	D	F	G	L	R**	W
				Inches							
18	5"	B2530-18	45	18.00	27.00	7.69	11.44	6.06	4.50	1.56	7.50
20	5"	B2530-20	50	20.00	29.00	7.69	11.94	6.81	4.50	1.75	7.50
24	5"	B2530-24	55	23.75	33.00	7.69	12.69	8.19	4.50	2.06	7.50
30	5"	B2530-30	64	29.00	39.00	7.69	13.81	10.19	4.50	2.69	7.50
36	5"	B2530-36	73	32.25	45.00	7.69	15.06	12.19	4.50	3.56	7.50
42	5"	B2530-42	94	40.38	51.00	7.69	16.31	14.50	4.50	3.75	7.50

\*\* To top of discharge or bend pulleys, except tail pulley.

■ 6" bolt spacing recommended to permit adjustment.

# 35°

## Troughed Belt Training, Idlers Equal Length Rolls

### positive action type

(above deck mounting)

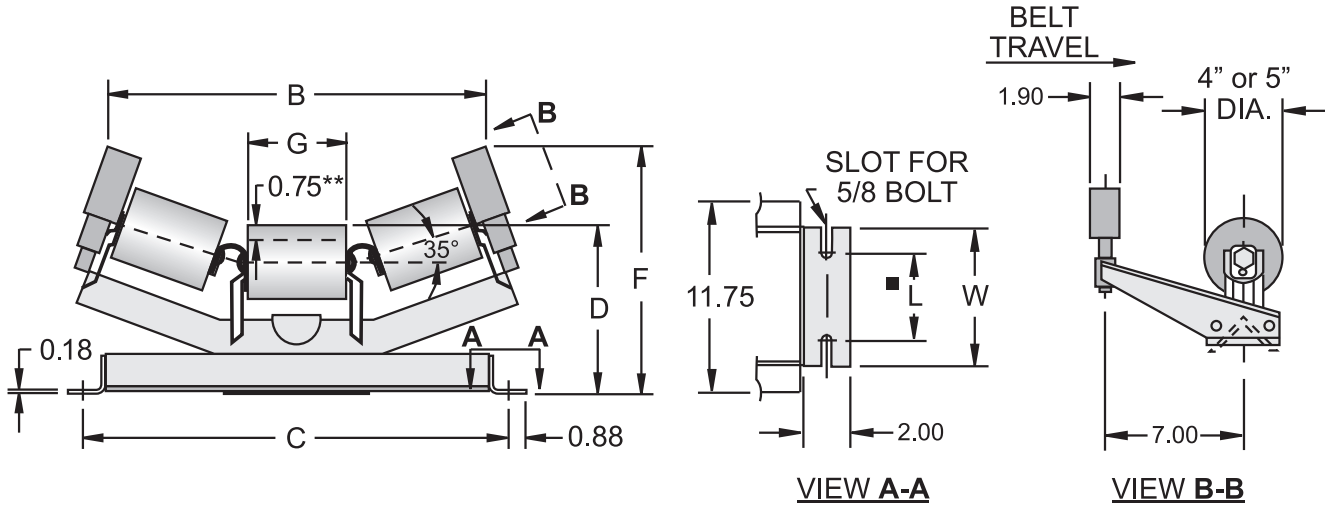

## CEMA B

Belt width, inches	Dia.	Idler number	Idler weight, pounds	B	C	D	F	G	L	W
				Inches						
14	4"	B2432-14	72	16.06	23.00	7.88	14.06	5.25	4.50	8.00
	5"	B2532-14	76	16.06	23.00	8.38	14.06	5.12	4.50	8.00
16	4"	B2432-16	78	17.69	25.00	7.88	14.38	5.88	4.50	8.00
	5"	B2532-16	82	17.69	25.00	8.38	14.38	5.75	4.50	8.00
18	4"	B2432-18	83	19.69	27.00	7.88	14.81	6.62	4.50	8.00
	5"	B2532-18	87	19.69	27.00	8.38	14.81	6.50	4.50	8.00
20	4"	B2432-20	88	21.31	29.00	7.88	15.19	7.25	4.50	8.00
	5"	B2532-20	92	21.31	29.00	8.38	15.19	7.12	4.50	8.00
24	4"	B2432-24	94	24.94	33.00	7.88	15.94	8.62	4.50	8.00
	5"	B2532-24	98	24.94	33.00	8.38	15.94	8.50	4.50	8.00
30	4"	B2432-30	109	30.19	39.00	7.88	17.12	10.62	4.50	8.00
	5"	B2532-30	114	30.19	39.00	8.38	17.12	10.50	4.50	8.00
36	4"	B2432-36	123	35.50	45.00	7.88	18.25	12.62	4.50	8.00
	5"	B2532-36	129	35.50	45.00	8.38	18.25	12.50	4.50	8.00
42	4"	B2432-42	145	40.75	51.00	7.88	19.44	14.62	4.50	8.00
	5"	B2532-42	152	40.75	51.00	8.38	19.44	14.50	4.50	8.00

\*\* Elevation above adjacent idlers.

■ 6" bolt spacing recommended to permit adjustment.

# 45° Troughed Belt Idlers, Equal Length Rolls

steel rolls

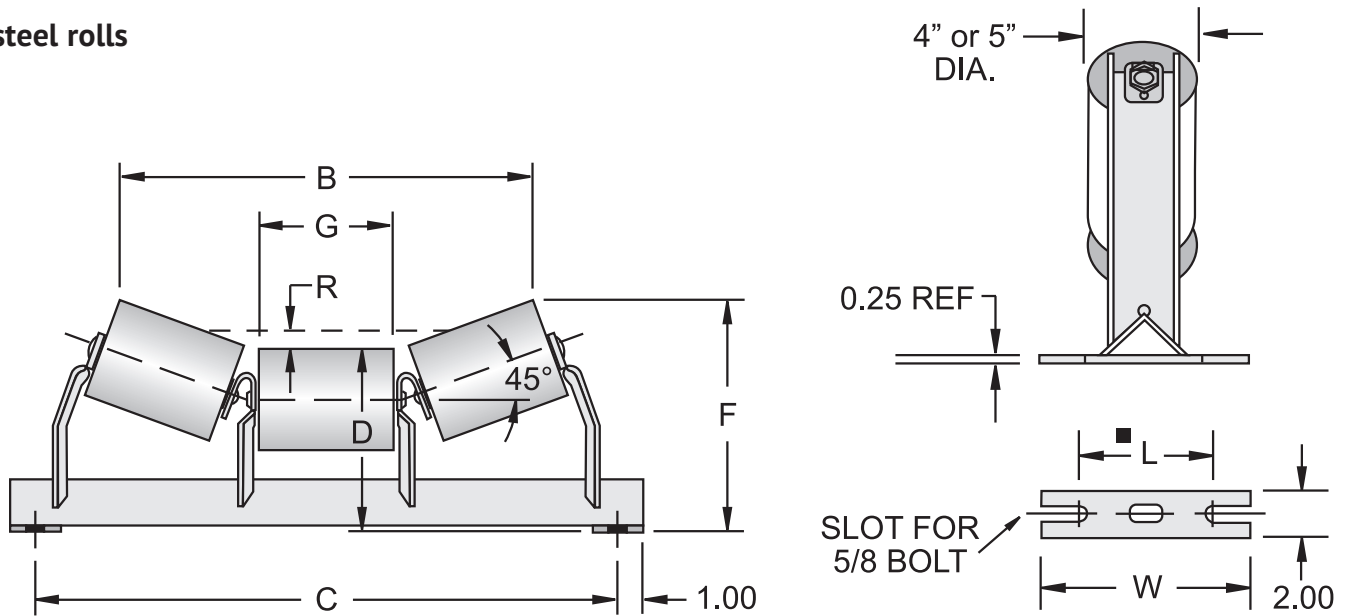

## CEMA B

Belt width, inches	Dia.	Idler number	Idler weight, pounds	B	C	D	F	G	L	R**	W
				Inches							
14	4"	B2402-14	27	13.19	23.00	7.19	11.06	5.25	4.50	1.56	7.50
	5"	B2502-14	31	12.38	23.00	7.69	11.38	5.12	4.50	1.56	7.50
16	4"	B2402-16	30	14.69	25.00	7.19	11.50	5.88	4.50	1.81	7.50
	5"	B2502-16	34	13.88	25.00	7.69	11.81	5.75	4.50	1.81	7.50
18	4"	B2402-18	31	16.50	27.00	7.19	12.00	6.62	4.50	2.00	7.50
	5"	B2502-18	35	15.69	27.00	7.69	12.31	6.50	4.50	2.00	7.50
20	4"	B2402-20	34	18.00	29.00	7.19	12.44	7.25	4.50	2.25	7.50
	5"	B2502-20	38	17.25	29.00	7.69	12.75	7.12	4.50	2.25	7.50
24	4"	B2402-24	37	21.31	33.00	7.19	13.44	8.62	4.50	2.75	7.50
	5"	B2502-24	42	20.56	33.00	7.69	13.75	8.50	4.50	2.75	7.50
30	4"	B2402-30	41	26.19	39.00	7.19	14.81	10.62	4.50	3.38	7.50
	5"	B2502-30	48	25.38	39.00	7.69	15.12	10.50	4.50	3.38	7.50
36	4"	B2402-36	47	31.00	45.00	7.19	16.25	12.62	4.50	4.12	7.50
	5"	B2502-36	55	30.19	45.00	7.69	16.56	12.50	4.50	4.12	7.50
42	4"	B2402-42	53	35.81	51.00	7.19	17.69	14.62	4.50	4.81	7.50
	5"	B2502-42	62	35.06	51.00	7.69	18.00	14.50	4.50	4.81	7.50

\*\* To top of discharge or bend pulleys, except tail pulley.

■ 6" bolt spacing recommended to permit adjustment.



# 45° Troughed Belt Idlers, Equal Length Rolls

rubber cushion rolls (impact)

(demountable end brackets)

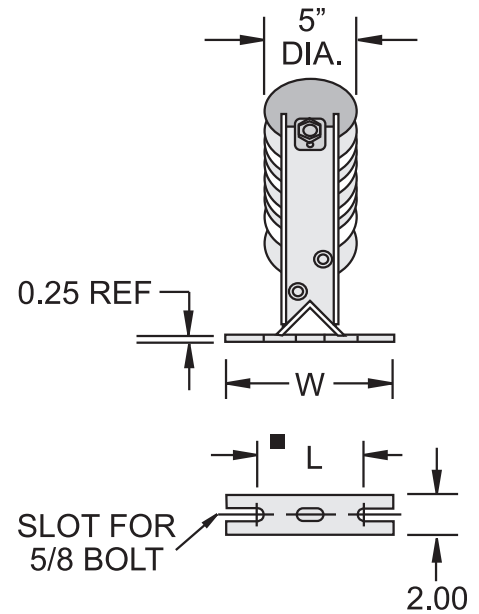
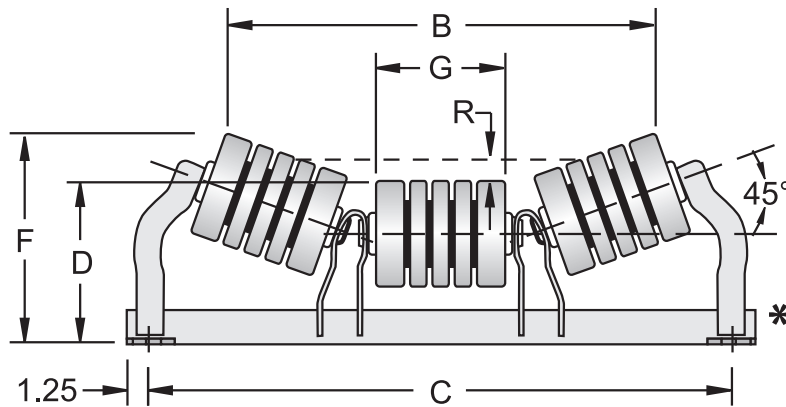

## CEMA B

Belt width, inches	Dia.	Idler number	Idler weight, pounds	B	C	D	F	G	L	R**	W
				Inches							
20	5"	B2523-20	51	17.50	29.00	7.69	13.94	6.81	4.50	2.69	7.50
24	5"	B2523-24	57	22.25	33.00	7.69	15.69	8.19	4.50	3.12	7.50
30	5"	B2523-30	66	27.00	39.00	7.69	16.81	10.19	4.50	3.75	7.50
36	5"	B2523-36	76	31.88	45.00	7.69	18.81	12.19	4.50	4.69	7.50

\*\* To top of discharge or bend pulleys, except tail pulley.

■ 6" bolt spacing recommended to permit adjustment.

# 45° Troughed Belt Training Idlers, Equal Length Rolls

positive action type

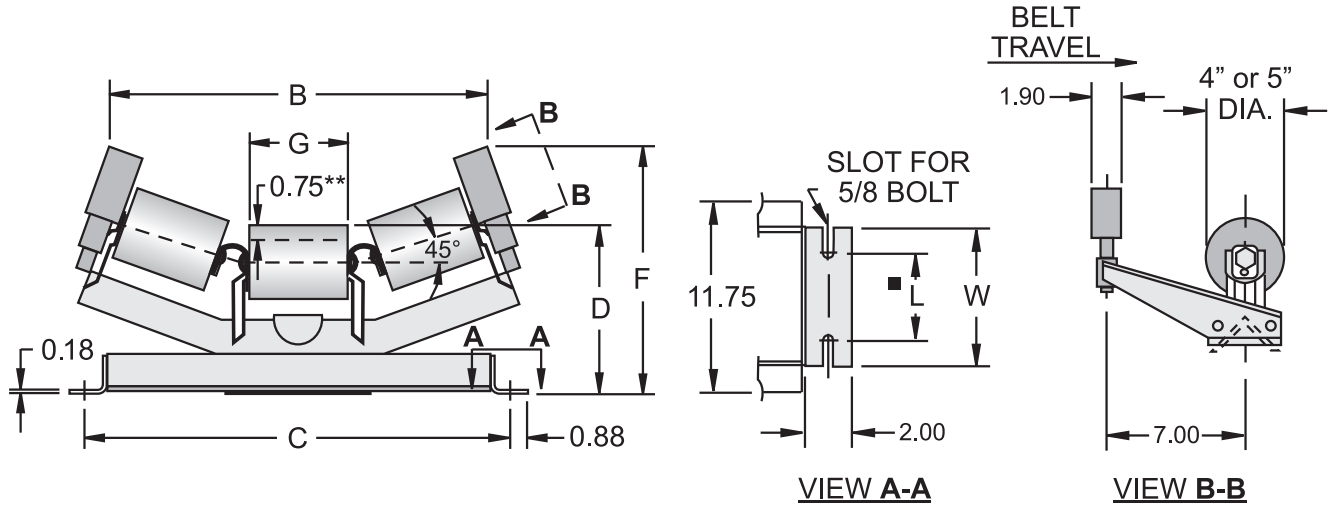

## CEMA B

Belt width, inches	Dia.	Idler number	Idler weight, pounds	B	C	D	F	G	L	W
				Inches						
14	4"	B2409-14	73	13.38	23.00	7.88	14.75	5.25	4.50	8.00
	5"	B2509-14	77	13.38	23.00	8.38	14.75	5.12	4.50	8.00
16	4"	B2409-16	79	14.88	25.00	7.88	15.19	5.88	4.50	8.00
	5"	B2509-16	83	14.88	25.00	8.38	15.19	5.75	4.50	8.00
18	4"	B2409-18	84	16.69	27.00	7.88	15.75	6.62	4.50	8.00
	5"	B2509-18	88	16.69	27.00	8.38	15.75	6.50	4.50	8.00
20	4"	B2409-20	89	18.19	29.00	7.88	16.19	7.25	4.50	8.00
	5"	B2509-20	93	18.19	29.00	8.38	16.19	7.12	4.50	8.00
24	4"	B2409-24	95	21.50	33.00	7.88	17.12	8.62	4.50	8.00
	5"	B2509-24	100	21.50	33.00	8.38	17.12	8.50	4.50	8.00
30	4"	B2409-30	110	26.31	39.00	7.88	18.56	10.62	4.50	8.00
	5"	B2509-30	115	26.31	39.00	8.38	18.56	10.50	4.50	8.00
36	4"	B2409-36	124	31.19	45.00	7.88	20.00	12.62	4.50	8.00
	5"	B2509-36	130	31.19	45.00	8.38	20.00	12.50	4.50	8.00

\*\* Elevation above adjacent idlers.

■ 6" bolt spacing recommended to permit adjustment.

# Flat Belt Idlers

steel rolls

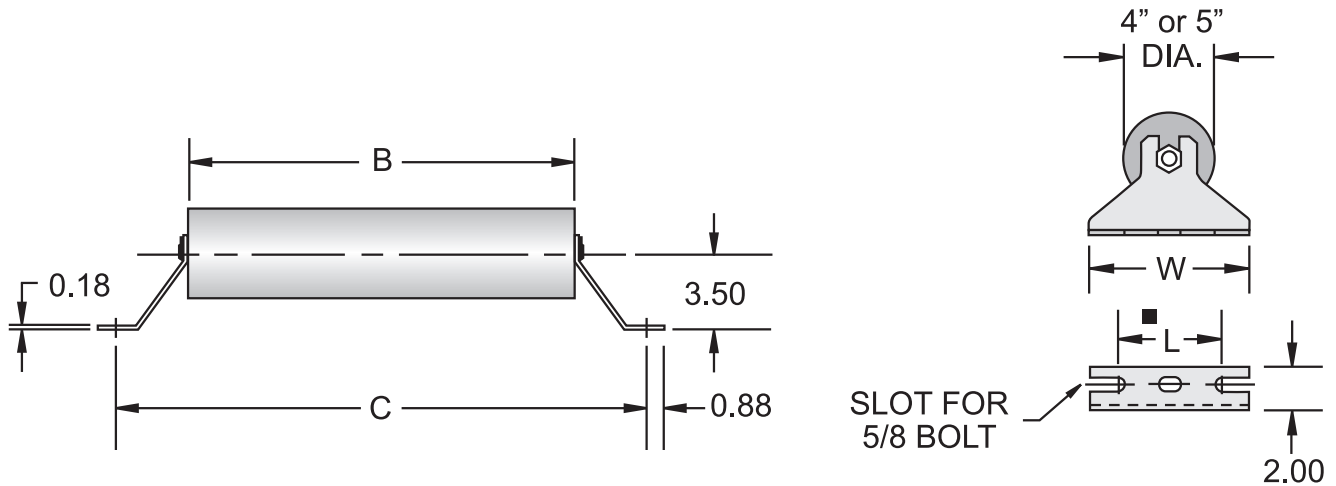

## CEMA B

Belt width, inches	Dia.	Idler number	Idler weight, pounds	B	C	L	W
				Inches			
14	4"	B2413-14	14	16.75	23.00	4.50	7.50
	5"	B2513-14	16	16.62	23.00	4.50	7.50
16	4"	B2413-16	15	18.75	25.00	4.50	7.50
	5"	B2513-16	18	18.62	25.00	4.50	7.50
18	4"	B2413-18	16	20.75	27.00	4.50	7.50
	5"	B2513-18	19	20.62	27.00	4.50	7.50
20	4"	B2413-20	17	22.75	29.00	4.50	7.50
	5"	B2513-20	20	22.62	29.00	4.50	7.50
24	4"	B2413-24	20	26.75	33.00	4.50	7.50
	5"	B2513-24	23	26.62	33.00	4.50	7.50
30	4"	B2413-30	24	32.75	39.00	4.50	7.50
	5"	B2513-30	27	32.62	39.00	4.50	7.50
36	4"	B2413-36	28	38.75	45.00	4.50	7.50
	5"	B2513-36	32	38.62	45.00	4.50	7.50
42	4"	B2413-42	31	44.75	51.00	4.50	7.50
	5"	B2513-42	36	44.62	51.00	4.50	7.50

■ 6" bolt spacing recommended to permit adjustment.

# Flat Belt Training Idlers

steel rolls, positive action type

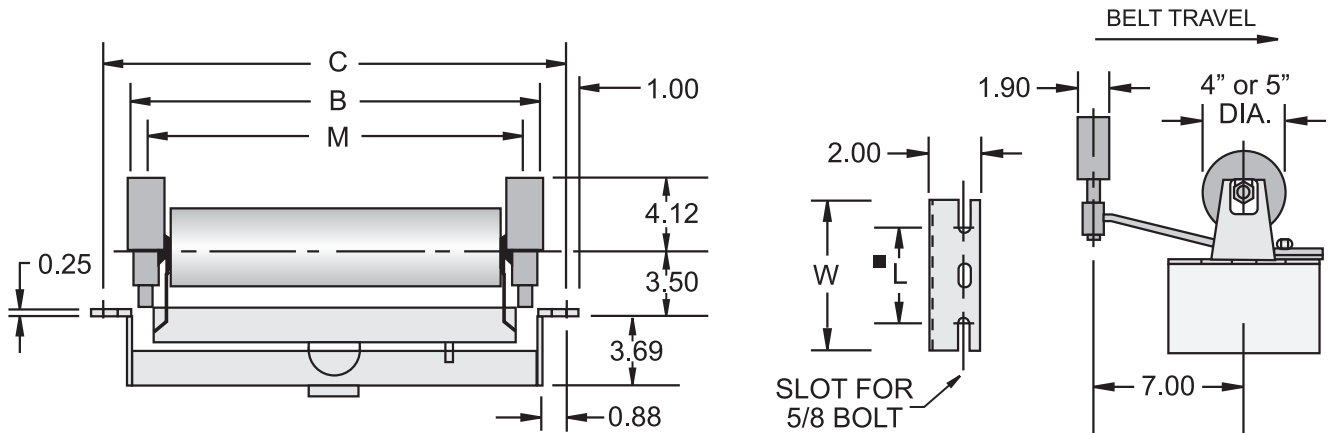

## CEMA B

Belt width, inches	Dia.	Idler number	Idler weight, pounds	B	C	M	L	W
				Inches				
14	4"	B2414-14	67	21.12	23.00	16.75	4.50	7.50
	5"	B2514-14	69	21.12	23.00	16.62	4.50	7.50
16	4"	B2414-16	70	23.12	25.00	18.75	4.50	7.50
	5"	B2514-16	73	23.12	25.00	18.62	4.50	7.50
18	4"	B2414-18	72	25.12	27.00	20.75	4.50	7.50
	5"	B2514-18	76	25.12	27.00	20.62	4.50	7.50
20	4"	B2414-20	75	27.12	29.00	22.75	4.50	7.50
	5"	B2514-20	79	27.12	29.00	22.62	4.50	7.50
24	4"	B2414-24	83	31.12	33.00	26.75	4.50	7.50
	5"	B2514-24	85	31.12	33.00	26.62	4.50	7.50
30	4"	B2414-30	88	37.12	39.00	32.75	4.50	7.50
	5"	B2514-30	91	37.12	39.00	32.62	4.50	7.50
36	4"	B2414-36	94	43.12	45.00	38.75	4.50	7.50
	5"	B2514-36	101	43.12	45.00	38.62	4.50	7.50
42	4"	B2414-42	103	49.12	51.00	44.75	4.50	7.50
	5"	B2514-42	108	49.12	51.00	44.62	4.50	7.50

■ 6" bolt spacing recommended to permit adjustment.

# Return Belt Idlers

steel rolls

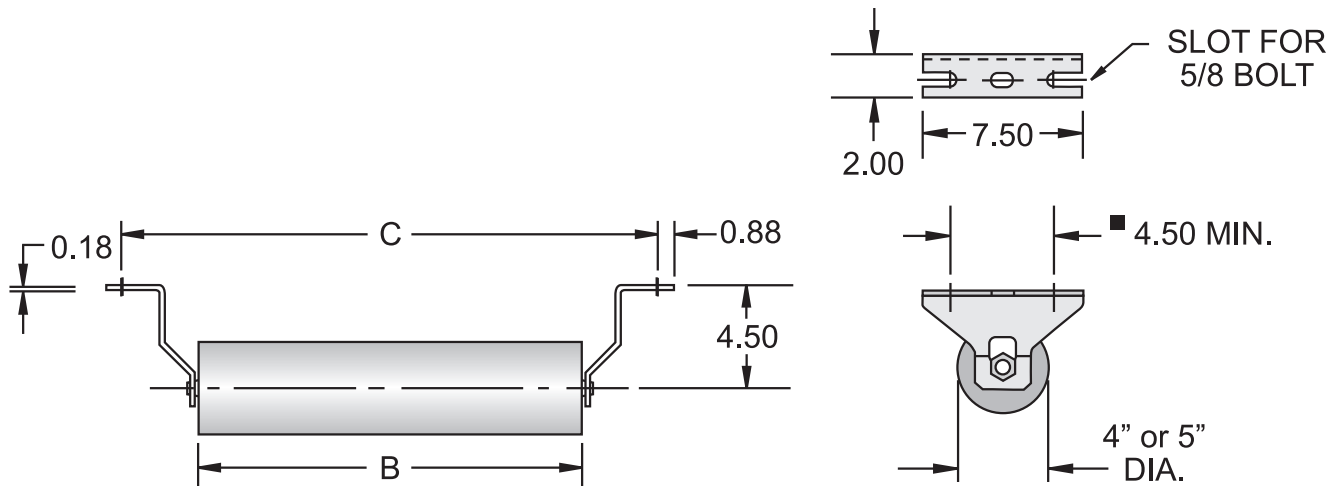

## CEMA B

Belt width, inches	Dia.	Idler number	Idler weight, pounds	Inches	
				B	C
14	4"	B2417-14	15	16.75	23.00
	5"	B2517-14	17	16.62	23.00
16	4"	B2417-16	17	18.75	25.00
	5"	B2517-16	19	18.62	25.00
18	4"	B2417-18	17	20.75	27.00
	5"	B2517-18	20	20.62	27.00
20	4"	B2417-20	18	22.75	29.00
	5"	B2517-20	21	22.62	29.00
24	4"	B2417-24	21	26.75	33.00
	5"	B2517-24	25	26.62	33.00
30	4"	B2417-30	25	32.75	39.00
	5"	B2517-30	28	32.62	39.00
36	4"	B2417-36	29	38.75	45.00
	5"	B2517-36	33	38.62	45.00
42	4"	B2417-42	32	44.75	51.00
	5"	B2517-42	37	44.62	51.00

■ 6" bolt spacing recommended to permit adjustment.

# Return Belt Idlers

rubber tread rolls

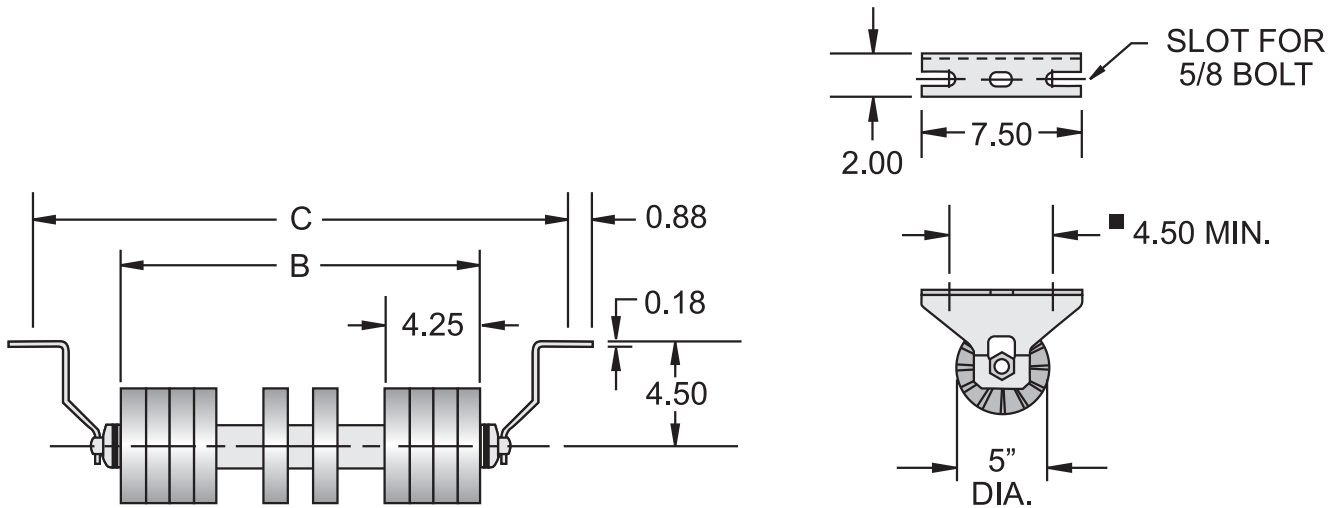

## CEMA B

Belt width, inches	Dia.	Idler number	Idler weight, pounds	B	C	Number of treads
				Inches		
14	5"	B2518-14	31	15.69	23.00	9
16	5"	B2518-16	32	17.69	25.00	9
18	5"	B2518-18	33	19.69	27.00	10
20	5"	B2518-20	34	21.69	29.00	10
24	5"	B2518-24	38	25.69	33.00	11
30	5"	B2518-30	42	31.69	39.00	12
36	5"	B2518-36	50	37.69	45.00	13
42	5"	B2518-42	54	43.69	51.00	15

■ 6" bolt spacing recommended to permit adjustment.



# Return Belt Training Idlers

steel rolls, positive action type

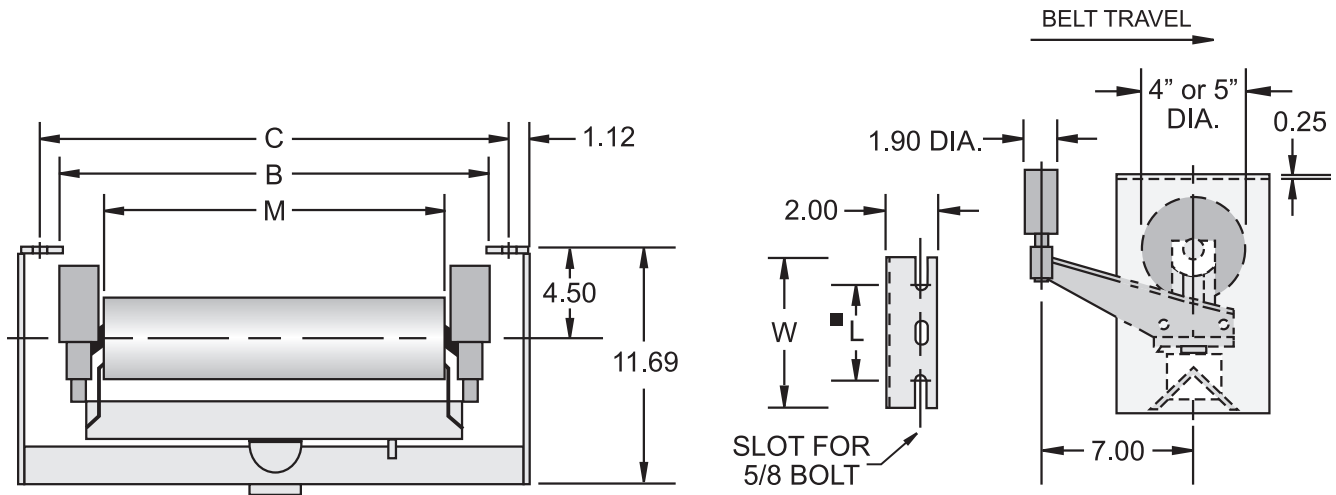

## CEMA B

Belt width, inches	Dia.	Idler number	Idler weight, pounds	B	C	M	L	W
				Inches				
14	4"	B2420-14	74	21.12	23.00	16.75	4.50	7.50
	5"	B2520-14	76	21.12	23.00	16.62	4.50	7.50
16	4"	B2420-16	77	23.12	25.00	18.75	4.50	7.50
	5"	B2520-16	79	23.12	25.00	18.62	4.50	7.50
18	4"	B2420-18	79	25.12	27.00	20.75	4.50	7.50
	5"	B2520-18	81	25.12	27.00	20.62	4.50	7.50
20	4"	B2420-20	82	27.12	29.00	22.75	4.50	7.50
	5"	B2520-20	85	27.12	29.00	22.62	4.50	7.50
24	4"	B2420-24	89	31.12	33.00	26.75	4.50	7.50
	5"	B2520-24	92	31.12	33.00	26.62	4.50	7.50
30	4"	B2420-30	95	37.12	39.00	32.75	4.50	7.50
	5"	B2520-30	99	37.12	39.00	32.62	4.50	7.50
36	4"	B2420-36	101	43.12	45.00	38.75	4.50	7.50
	5"	B2520-36	105	43.12	45.00	38.62	4.50	7.50
42	4"	B2420-42	110	49.12	51.00	44.75	4.50	7.50
	5"	B2520-42	115	49.12	51.00	44.62	4.50	7.50

■ 6" bolt spacing recommended to permit adjustment.

# Return Belt Training Idlers

rubber tread rolls, positive action type

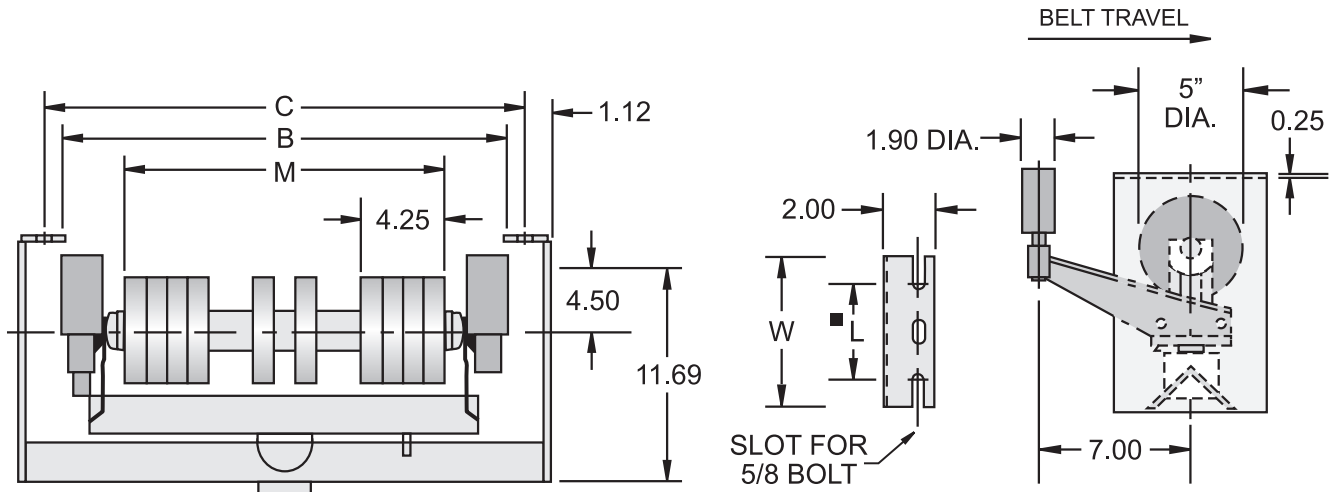

## CEMA B

Belt width, inches	Dia.	Idler number	Idler weight, pounds	B	C	M	L	W	Number of treads
				Inches					
14	5"	B2521-14	83	21.12	23.00	15.69	4.50	7.50	9
16	5"	B2521-16	86	23.12	25.00	17.69	4.50	7.50	9
18	5"	B2521-18	89	25.12	27.00	19.69	4.50	7.50	10
20	5"	B2521-20	92	27.12	29.00	21.69	4.50	7.50	10
24	5"	B2521-24	100	31.12	33.00	25.69	4.50	7.50	11
30	5"	B2521-30	105	37.12	39.00	31.69	4.50	7.50	12
36	5"	B2521-36	114	43.12	45.00	37.69	4.50	7.50	13
42	5"	B2521-42	125	49.12	51.00	43.69	4.50	7.50	15

■ 6" bolt spacing recommended to permit adjustment.

# Ordering Replacement Rolls

Below are the part numbers to reference when ordering sealed replacement rolls for CEMA Series B2000. Frame is not included.

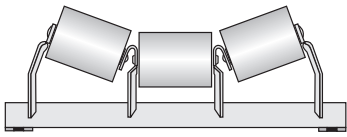

The following part numbers fit  
**4”** diameter steel troughing rolls for B2401, B2402, B2407, B2409,  
B2428 and B2432 idlers

## B2000 Replacement Rolls

Belt Width	Part Number
14	1726-112-A
16	1726-112-B
18	1726-112-C
20	1726-112-D
24	1726-112-E
30	1726-112-F
36	1726-112-G
42	1726-112-H

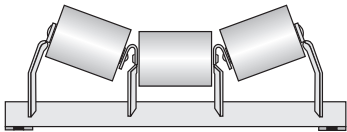

The following part numbers fit  
**5”** diameter steel troughing rolls for B2501, B2502, B2507, B2509,  
B2528 and B2532 idlers

## B2000 Replacement Rolls

Belt Width	Part Number
14	1726-112-AA
16	1726-112-AB
18	1726-112-AC
20	1726-112-AD
24	1726-112-AE
30	1726-112-AF
36	1726-112-AG
42	1726-112-AH

# Ordering Replacement Rolls

Below are the part numbers to reference when ordering sealed replacement rolls for CEMA Series B2000. Frame is not included.

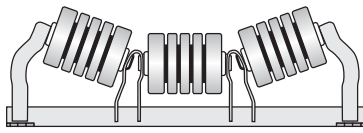

The following part numbers fit

**5”** diameter rubber cushion troughing rolls for B2504, B2523 and B2530 idlers

## B2000 Replacement Rolls

Belt Width	Part Number
18	1730-327-A.S
20	1730-327-B.S
24	1730-327-C.S
30	1730-327-D.S
36	1730-327-E.S
42	1730-327-F.S

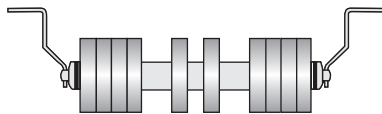

The following part numbers fit

**5”** diameter rubber tread return rolls for B2518 and B2521 idlers

## B2000 Replacement Rolls

Belt Width	Part Number
14	1726-108-A
16	1726-108-B
18	1726-108-C
20	1726-108-D
24	1726-108-E
30	1726-108-F
36	1726-108-G
42	1726-108-H

# Ordering Replacement Rolls

Below are the part numbers to reference when ordering sealed replacement rolls for CEMA Series B2000. Frame is not included.



The following part numbers fit  
**4”** diameter steel return/carrying rolls for B2413, B2414, B2417 and B2420 idlers

## B2000 Replacement Rolls

Belt Width	Part Number
14	1726-112-L
16	1726-112-M
18	1726-112-N
20	1726-112-P
24	1726-112-R
30	1726-112-S
36	1726-112-T
42	1726-112-U



The following part numbers fit  
**5”** diameter steel return/carrying rolls for B2513, B2514, B2517 and B2520 idlers

## B2000 Replacement Rolls

Belt Width	Part Number
14	1726-112-AL
16	1726-112-AM
18	1726-112-AN
20	1726-112-AP
24	1726-112-AR
30	1726-112-AS
36	1726-112-AT
42	1726-112-AU

# CEMA Series C2000 Idlers

## Bearings

- Link-Belt® CEMA C Rolls contain 6304 deep groove ball bearings, which have a 20% higher basic dynamic load rating than the commonly used 6204 bearing.

## Frames

- Inverted angle frame base with slotted foot straps to ensure quick, easy mounting and alignment
- Heavy-duty, die-formed, steel end brackets are contoured for generous clearance to safeguard against spilled materials becoming jammed and impeding the rotation of the rollers
- All idler frames are welded in accordance with AWS D1.1 specifications for structural welds

## Seal

- Rubber double lip contact seal paired with a polymer deflector with integrated labyrinth seal for robust, redundant sealing capability
- Seal works well in dusty conditions and wash down environments

## Coatings

- Frames and rolls are powder-coated (see page 155 for details)
- Assembly hardware is electro-zinc plated

## CEMA

- Idlers meet or exceed CEMA requirements for rugged, continuous material handling
- Multiple belt widths and models available to meet your needs

## Roll Thickness

- 5" diameter = 11 ga (0.120)
- 6" diameter = 11 ga (0.120)

## Testing Capabilities

- Load rating
- Seal life
- Roll concentricity
- Roll resistance
- Roll imbalance
- Water resistance

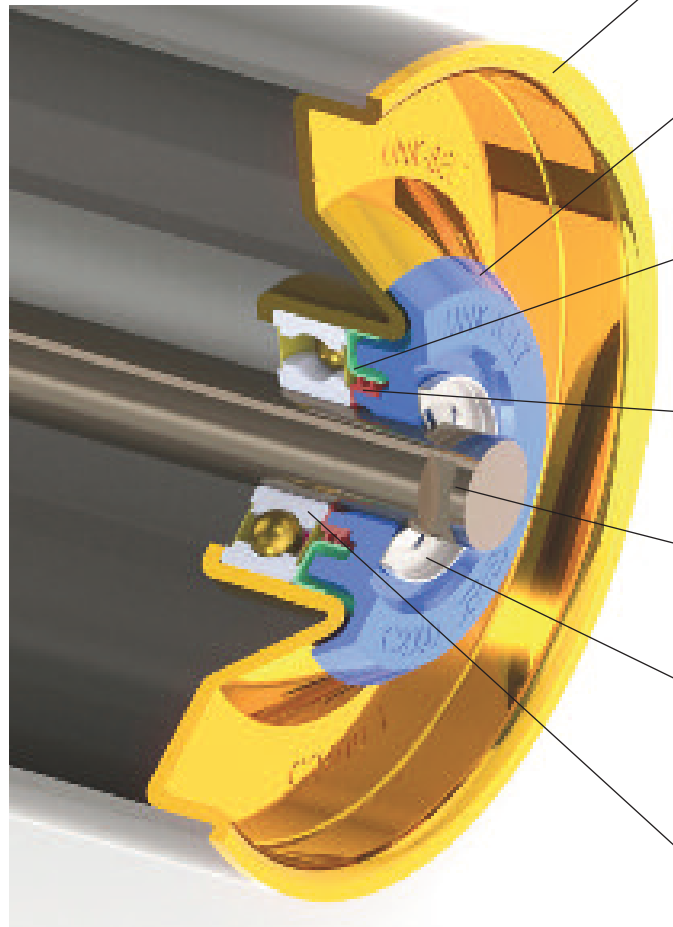

**Pressed Head:** Precision formed pressed head. Designed to provide strength and rigidity while offering reduced weight. Excellent roll concentricity and balance. Yellow Zinc plated for corrosion resistance.

**Deflector:** Impact and corrosion resistant deflector provides first line protection against abrasive materials and washdown water.

**Triple Labyrinth Seal:** Durable, zinc plated inner metal labyrinth seal serves to fling out material and water while providing a smooth, corrosion resistant, heat conductive surface for the contact seal.

**Contact Lip Seal:** Special wear resistant contact seal provides sealing against abrasive fines and washdown water. Suitable for dry, wet, and cold temperature conditions.

**Solid Shaft:** High strength, cold finished low carbon C1018 shafting. Broached shaft end slots anchor the roll assembly securely to the frame.

**Retaining Ring:** Corrosion resistant stainless steel retaining ring eliminates any possible shaft end-play while firmly securing the roll assembly under load.

**Deep Groove Bearings:** Distance from the bearings and shaft ends is minimized to reduce shaft deflection at the bearings. Standard 2RS rubber seals add another level of protection against material and water.

C2000 / 6304-2RS / 20mm



## Carrying Idler Types

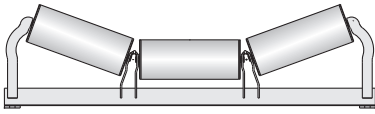

**Troughed belt idlers** for general carrying service are available with roll inclinations of 20°, 35°, and 45°.

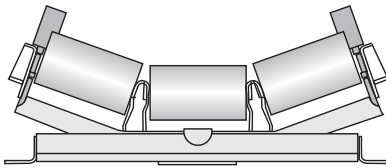

**Troughed belt training idlers** automatically train belts and protect belt edges from damage caused by misalignment. Positive action type available for belts operating in one direction, and actuating shoe type available for two-directional operation (reversing).

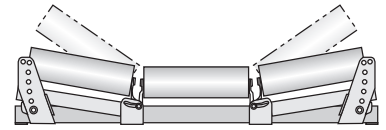

**Variable troughed belt idlers** placed between the final troughing idler and the head pulley, support the belt during its transition from a concave to a flat contour. The end rolls can be adjusted vertically to match the changing contour of the belt during this critical period of transition.

## Return Idler Types



**Return belt idlers** carry the empty belt on the return run.

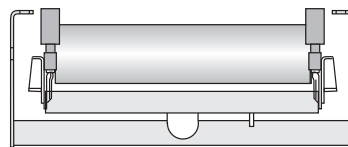

**Return belt training idlers** train the belt and protect its edges from damage caused by misalignment. Positive action type for belts operating in one direction. Actuating shoe type for reversing belts.





# 20° Troughed Belt Idlers, Equal Length Rolls

steel rolls

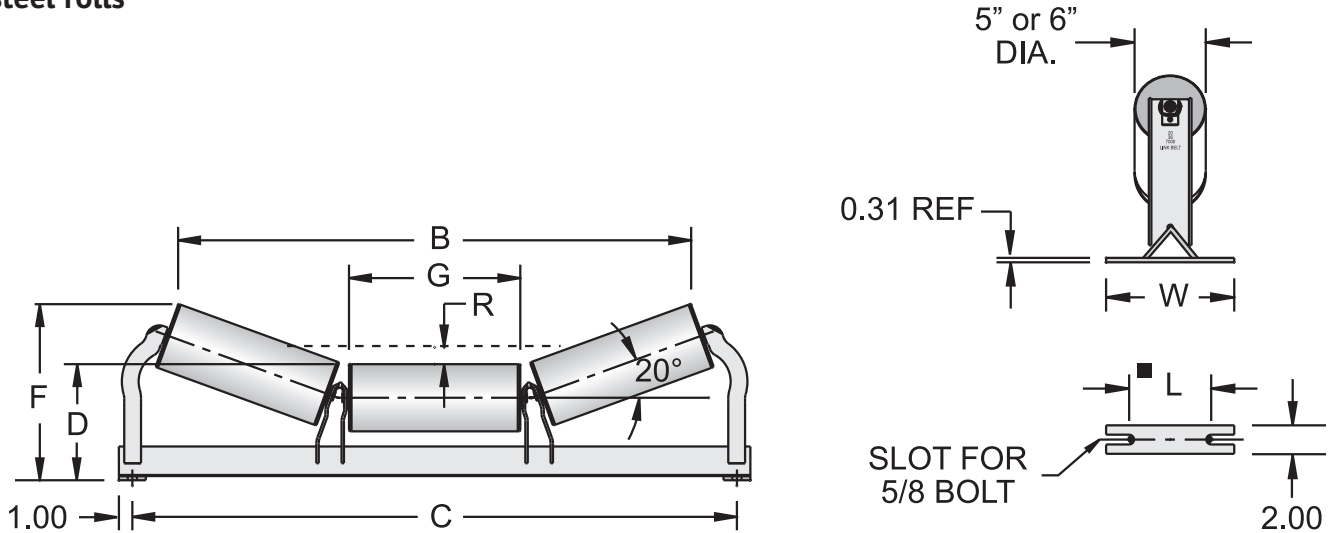

## CEMA C

Belt width, inches	Dia.	Idler number	Standard Base (Belt width + 9")		B	D	F	G	L	R**	W
			Idler weight, pounds	C							
					Inches						
18	5"	C2501-18	43	27.00	20.36	8.27	10.63	6.44	5.75	0.94	9.00
	6"	C2601-18	47	27.00	19.76	8.77	11.04	6.19	5.75	0.94	9.00
20	5"	C2501-20	45	29.00	22.52	8.27	10.89	7.19	5.75	1.00	9.00
	6"	C2601-20	50	29.00	21.95	8.77	11.30	6.94	5.75	1.00	9.00
24	5"	C2501-24	49	33.00	26.46	8.27	11.36	8.56	5.75	1.25	9.00
	6"	C2601-24	55	33.00	25.89	8.77	11.77	8.31	5.75	1.25	9.00
30	5"	C2501-30	57	39.00	32.22	8.63	12.40	10.56	5.75	1.62	9.00
	6"	C2601-30	63	39.00	31.65	9.13	12.82	10.31	5.75	1.62	9.00
36	5"	C2501-36	64	45.00	37.98	8.63	13.09	12.56	5.75	1.94	9.00
	6"	C2601-36	70	45.00	37.41	9.13	13.50	12.31	5.75	1.94	9.00
42	5"	C2501-42	83	51.00	44.66	9.00	14.25	14.88	5.75	2.25	9.00
	6"	C2601-42	89	51.00	44.06	9.50	14.66	14.63	5.75	2.25	9.00
48	5"	C2501-48	91	57.00	50.42	9.00	14.93	16.88	5.75	2.62	9.00
	6"	C2601-48	99	57.00	49.82	9.50	15.34	16.63	5.75	2.62	9.00
54	5"	C2501-54	99	63.00	56.35	9.00	15.64	18.94	5.75	2.94	9.00
	6"	C2601-54	106	63.00	55.75	9.50	16.05	18.69	5.75	2.94	9.00
60	5"	C2501-60	107	69.00	62.11	9.00	16.32	20.94	5.75	3.25	9.00
	6"	C2601-60	115	69.00	61.51	9.50	16.73	20.69	5.75	3.25	9.00

\*\* To top of discharge or bend pulleys, except tail pulley.

■ 7.5" bolt spacing recommended to permit adjustment.

# 20° Troughed Belt Training Idlers, Equal Length Rolls

**positive action type**  
(above deck mounting)

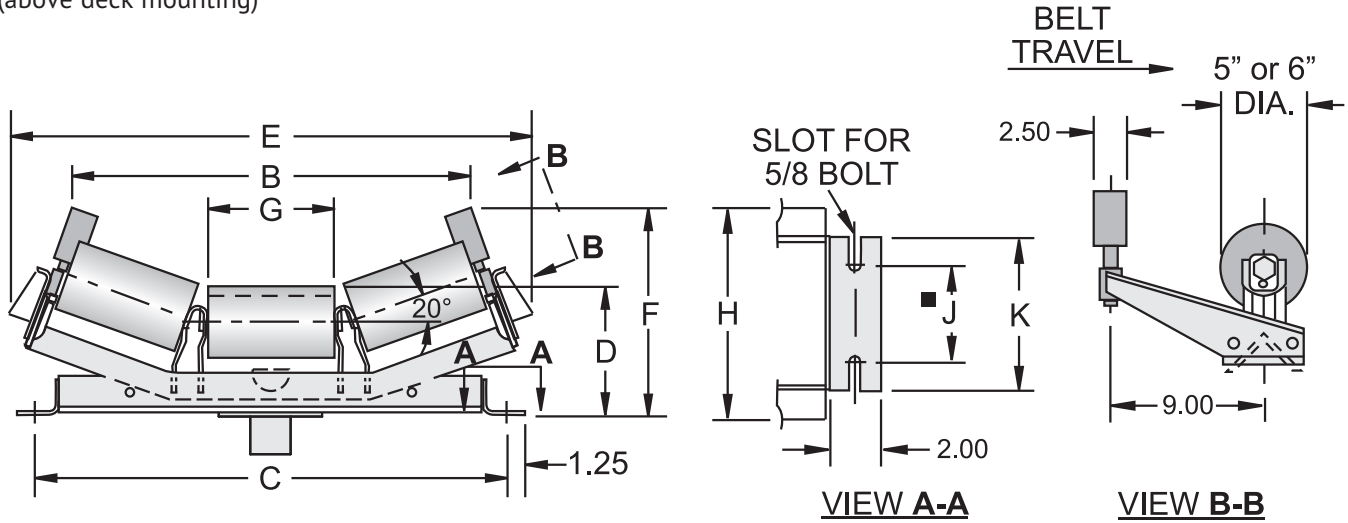

## CEMA C

Belt width, inches	Dia.	Idler number	Standard Base (Belt width + 9")		B	D	E	F	G	H	J	K
			Idler weight, pounds	C								
18	5"	C2507-18	95	27.00	23.38	8.50	30.04	12.91	6.44	12.00	5.75	9.12
	6"	C2607-18	99	27.00	23.38	9.00	30.04	12.91	6.19	12.00	5.75	9.12
20	5"	C2507-20	99	29.00	25.54	8.50	32.20	13.17	7.19	12.00	5.75	9.12
	6"	C2607-20	103	29.00	25.54	9.00	32.20	13.17	6.94	12.00	5.75	9.12
24	5"	C2507-24	106	33.00	29.48	8.50	36.14	13.64	8.56	12.00	5.75	9.12
	6"	C2607-24	111	33.00	29.48	9.00	36.14	13.64	8.31	12.00	5.75	9.12
30	5"	C2507-30	128	39.00	35.24	8.75	41.90	14.57	10.56	14.50	5.75	10.50
	6"	C2607-30	134	39.00	35.24	9.25	41.90	14.57	10.31	4.50	5.75	10.50
36	5"	C2507-36	141	45.00	41.00	8.75	47.66	15.26	12.56	14.50	5.75	10.50
	6"	C2607-36	146	45.00	41.00	9.25	47.66	15.26	12.31	14.50	5.75	10.50
42	5"	C2507-42	193	51.00	47.67	8.75	54.33	16.42	14.88	17.00	5.75	13.00
	6"	C2607-42	200	51.00	47.67	9.25	54.33	16.42	14.63	17.00	5.75	13.00
48	5"	C2507-48	209	57.00	53.43	9.12	60.09	17.11	16.88	17.00	5.75	13.00
	6"	C2607-48	216	57.00	53.43	9.62	60.09	17.11	16.63	17.00	5.75	13.00
54	5"	C2507-54	223	63.00	59.37	9.12	66.03	17.81	18.94	17.00	5.75	13.00
	6"	C2607-54	231	63.00	59.37	9.62	66.03	17.81	18.69	17.00	5.75	13.00
60	5"	C2507-60	238	69.00	65.13	9.12	71.79	18.49	20.94	17.00	5.75	13.00
	6"	C2607-60	246	69.00	65.13	9.62	71.79	18.49	20.69	17.00	5.75	13.00

■ 7.5" bolt spacing recommended to permit adjustment.

# 20° Troughed Belt Training Idlers, Equal Length Rolls

actuating shoe type reversing belts

(above deck mounting)

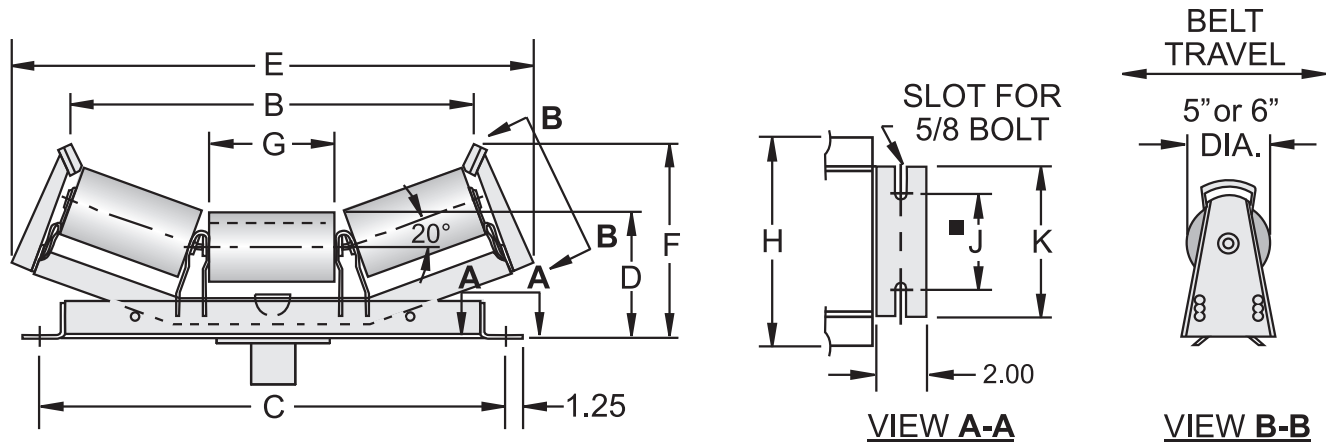

## CEMA C

Belt width, inches	Dia.	Idler number	Standard Base (Belt width + 9")		B	D	E	F	G	H	J	K
			Idler weight, pounds	C								
Inches												
18	5"	C2508-18	88	27.00	22.53	8.50	31.00	12.59	6.44	12.00	5.75	9.12
	6"	C2608-18	92	27.00	22.19	9.00	30.66	13.06	6.19	12.00	5.75	9.12
20	5"	C2508-20	92	29.00	24.69	8.50	33.16	12.85	7.19	12.00	5.75	9.12
	6"	C2608-20	96	29.00	24.35	9.00	32.81	13.32	6.94	12.00	5.75	9.12
24	5"	C2508-24	99	33.00	28.63	8.50	37.10	13.31	8.56	12.00	5.75	9.12
	6"	C2608-24	104	33.00	28.29	9.00	36.76	13.78	8.31	12.00	5.75	9.12
30	5"	C2508-30	122	39.00	34.39	8.75	42.86	14.25	10.56	14.50	5.75	10.50
	6"	C2608-30	127	39.00	34.05	9.25	42.52	14.72	10.31	14.50	5.75	10.50
36	5"	C2508-36	134	45.00	40.15	8.75	48.62	14.93	12.56	14.50	5.75	10.50
	6"	C2608-36	140	45.00	39.81	9.25	48.28	15.40	12.31	14.50	5.75	10.50
42	5"	C2508-42	187	51.00	46.82	9.12	55.29	16.10	14.88	17.00	5.75	13.00
	6"	C2608-42	193	51.00	46.48	9.62	54.95	16.57	14.63	17.00	5.75	13.00
48	5"	C2508-48	202	57.00	52.58	9.12	61.05	16.78	16.88	17.00	5.75	13.00
	6"	C2608-48	209	57.00	52.24	9.62	60.71	17.25	16.63	17.00	5.75	13.00
54	5"	C2508-54	216	63.00	58.52	9.12	66.99	17.48	18.94	17.00	5.75	13.00
	6"	C2608-54	224	63.00	58.18	9.62	66.65	17.95	18.69	17.00	5.75	13.00
60	5"	C2508-60	231	69.00	64.28	9.12	72.75	18.17	20.94	17.00	5.75	13.00
	6"	C2608-60	239	69.00	63.94	9.62	72.41	18.64	20.69	17.00	5.75	13.00

■ 7.5" bolt spacing recommended to permit adjustment.

# 35°

## Troughed Belt Idlers, Equal Length Rolls

steel rolls

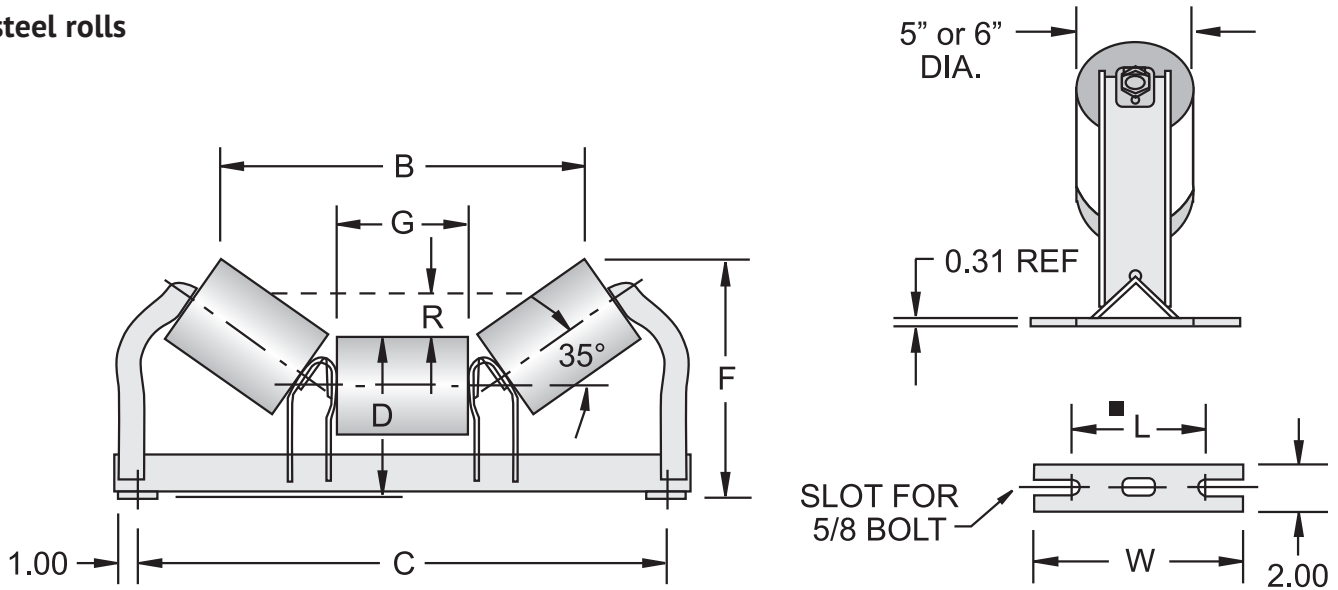

## CEMA C

Belt width, inches	Dia.	Idler number	Standard Base (Belt width + 9")		B	D	F	G	L	R**	W
			Idler weight, pounds	C							
18	5"	C2528-18	45	27.00	18.45	8.27	12.19	6.44	5.75	1.56	9.00
	6"	C2628-18	49	27.00	17.67	8.77	12.53	6.19	5.75	1.56	9.00
20	5"	C2528-20	47	29.00	20.43	8.27	12.62	7.19	5.75	1.75	9.00
	6"	C2628-20	51	29.00	19.65	8.77	12.96	6.94	5.75	1.75	9.00
24	5"	C2528-24	51	33.00	24.05	8.27	13.41	8.56	5.75	2.12	9.00
	6"	C2628-24	56	33.00	23.27	8.77	13.75	8.31	5.75	2.12	9.00
30	5"	C2528-30	59	39.00	29.32	8.63	14.92	10.56	5.75	2.69	9.00
	6"	C2628-30	65	39.00	28.54	9.13	15.25	10.31	5.75	2.69	9.00
36	5"	C2528-36	66	45.00	34.60	8.63	16.06	12.56	5.75	3.25	9.00
	6"	C2628-36	72	45.00	33.82	9.13	16.40	12.31	5.75	3.25	9.00
42	5"	C2528-42	86	51.00	40.72	9.00	17.76	14.88	5.75	3.81	9.00
	6"	C2628-42	92	51.00	39.94	9.50	18.10	14.63	5.75	3.81	9.00
48	5"	C2528-48	94	57.00	46.00	9.00	18.91	16.88	5.75	4.38	9.00
	6"	C2628-48	101	57.00	45.22	9.50	19.25	16.63	5.75	4.38	9.00
54	5"	C2528-54	101	63.00	51.43	9.00	20.10	18.94	5.75	4.94	9.00
	6"	C2628-54	109	63.00	50.65	9.50	20.43	18.69	5.75	4.94	9.00
60	5"	C2528-60	110	69.00	56.71	9.00	21.24	20.94	5.75	5.50	9.00
	6"	C2628-60	118	69.00	55.93	9.50	21.58	20.69	5.75	5.50	9.00

\*\* To top of discharge or bend pulleys, except tail pulley.

■ 7.5" bolt spacing recommended to permit adjustment.

# 35°

## Troughed Belt Training Idlers, Equal Length Rolls

### positive action type

(above deck mounting)

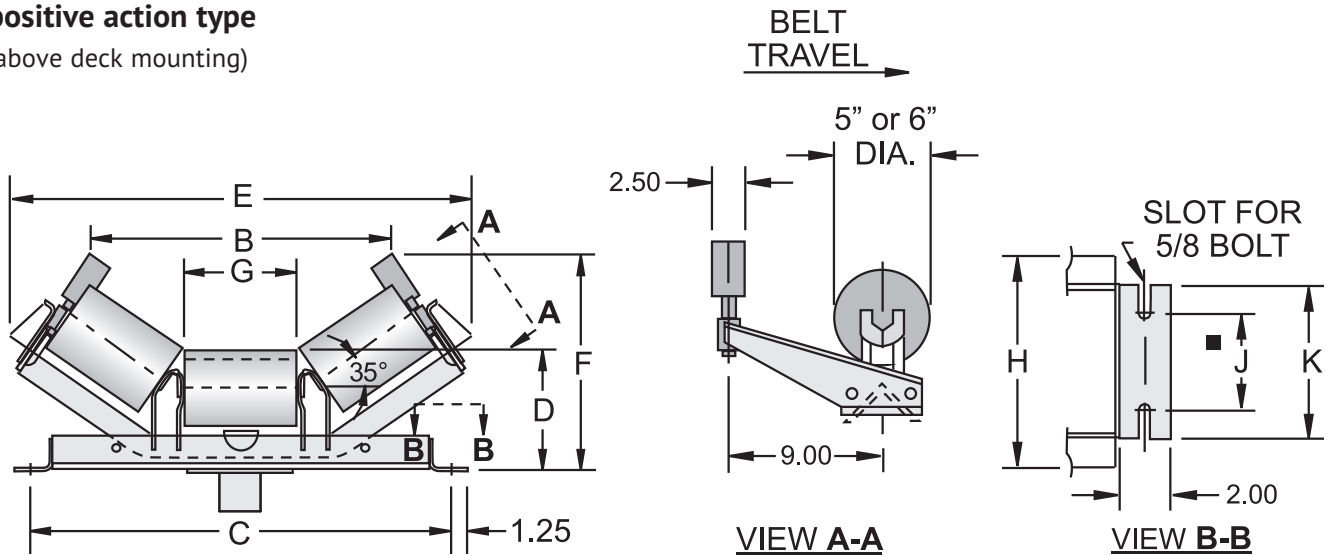

## CEMA C

Belt width, inches	Dia.	Idler number	Standard Base (Belt width + 9")		B	D	E	F	G	H	J	K
			Idler weight, pounds	C								
Inches												
18	5"	C2532-18	98	27.00	20.34	8.50	30.36	14.80	6.44	12.00	5.75	9.12
	6"	C2632-18	101	27.00	20.34	9.00	30.36	14.80	6.19	12.00	5.75	9.12
20	5"	C2532-20	101	29.00	22.32	8.50	32.34	15.23	7.19	12.00	5.75	9.12
	6"	C2632-20	106	29.00	22.32	9.00	32.34	15.23	6.94	12.00	5.75	9.12
24	5"	C2532-24	109	33.00	25.94	8.50	35.97	16.02	8.56	12.00	5.75	9.12
	6"	C2632-24	114	33.00	25.94	9.00	35.97	16.02	8.31	12.00	5.75	9.12
30	5"	C2532-30	130	39.00	31.22	8.75	41.25	17.42	10.56	14.00	5.75	10.00
	6"	C2632-30	135	39.00	31.22	9.25	41.25	17.42	10.31	14.00	5.75	10.00
36	5"	C2532-36	142	45.00	36.50	8.75	46.52	18.57	12.56	14.00	5.75	10.00
	6"	C2632-36	148	45.00	36.50	9.25	46.52	18.57	12.31	14.00	5.75	10.00
42	5"	C2532-42	193	51.00	42.60	9.12	52.62	20.27	14.88	16.00	5.75	12.00
	6"	C2632-42	200	51.00	42.60	9.62	52.62	20.27	14.63	16.00	5.75	12.00
48	5"	C2532-48	208	57.00	47.88	9.12	57.90	21.42	16.88	16.00	5.75	12.00
	6"	C2632-48	216	57.00	47.88	9.62	57.90	21.42	16.63	16.00	5.75	12.00
54	5"	C2532-54	223	63.00	53.32	9.12	63.34	22.60	18.94	16.00	5.75	12.00
	6"	C2632-54	231	63.00	53.32	9.62	63.34	22.60	18.69	16.00	5.75	12.00
60	5"	C2532-60	238	69.00	58.59	9.12	68.62	23.75	20.94	16.00	5.75	12.00
	6"	C2632-60	246	69.00	58.59	9.62	68.62	23.75	20.69	16.00	5.75	12.00

■ 7.5" bolt spacing recommended to permit adjustment.



# 35°

## Troughed Belt Training Idlers, Equal Length Rolls

### actuating shoe type

(above deck mounting)

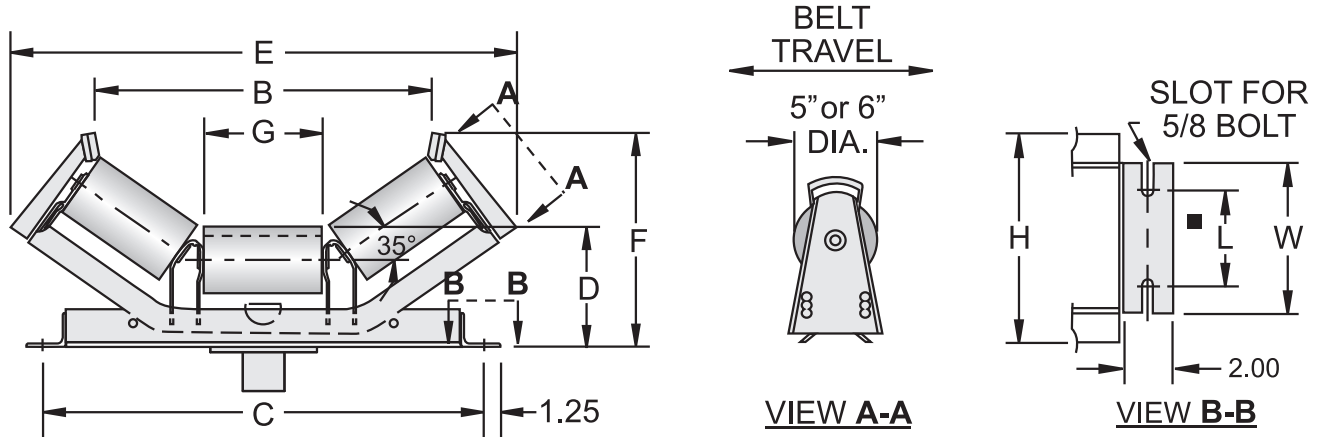

## CEMA C

Belt width, inches	Dia.	Idler number	Standard Base (Belt width + 9")		B	D	E	F	G	H	L	W
			Idler weight, pounds	C								
Inches												
18	5"	C2537-18	91	27.00	19.69	8.50	32.26	14.38	6.44	12.00	5.75	9.12
	6"	C2637-18	95	27.00	19.11	9.00	31.69	14.78	6.19	12.00	5.75	9.12
20	5"	C2537-20	95	29.00	21.67	8.50	34.24	14.81	7.19	12.00	5.75	9.12
	6"	C2637-20	99	29.00	21.09	9.00	33.67	15.21	6.94	12.00	5.75	9.12
24	5"	C2537-24	102	33.00	25.29	8.50	37.87	15.59	8.56	12.00	5.75	9.12
	6"	C2637-24	107	33.00	24.72	9.00	37.30	16.00	8.31	12.00	5.75	9.12
30	5"	C2537-30	123	39.00	30.57	8.75	43.15	16.99	10.56	14.00	5.75	10.00
	6"	C2637-30	128	39.00	30.00	9.25	42.57	17.40	10.31	14.00	5.75	10.00
36	5"	C2537-36	135	45.00	35.85	8.75	48.42	18.14	12.56	14.00	5.75	10.00
	6"	C2637-36	141	45.00	35.27	9.25	47.85	18.55	12.31	14.00	5.75	10.00
42	5"	C2537-42	187	51.00	41.95	9.12	54.52	19.84	14.88	16.00	5.75	12.00
	6"	C2637-42	193	51.00	41.37	9.62	53.95	20.25	14.63	16.00	5.75	12.00
48	5"	C2537-48	202	57.00	47.22	9.12	59.80	20.99	16.88	16.00	5.75	12.00
	6"	C2637-48	209	57.00	46.65	9.62	59.23	21.40	16.63	16.00	5.75	12.00
54	5"	C2537-54	216	63.00	52.66	9.12	65.24	22.17	18.94	16.00	5.75	12.00
	6"	C2637-54	224	63.00	52.09	9.62	64.67	22.59	18.69	16.00	5.75	12.00
60	5"	C2537-60	231	69.00	57.94	9.12	70.52	23.32	20.94	16.00	5.75	12.00
	6"	C2637-60	239	69.00	57.37	9.62	69.94	23.73	20.69	16.00	5.75	12.00

■ 7.5" bolt spacing recommended to permit adjustment.

# 45° Troughed Belt Idlers, Equal Length Rolls

steel rolls

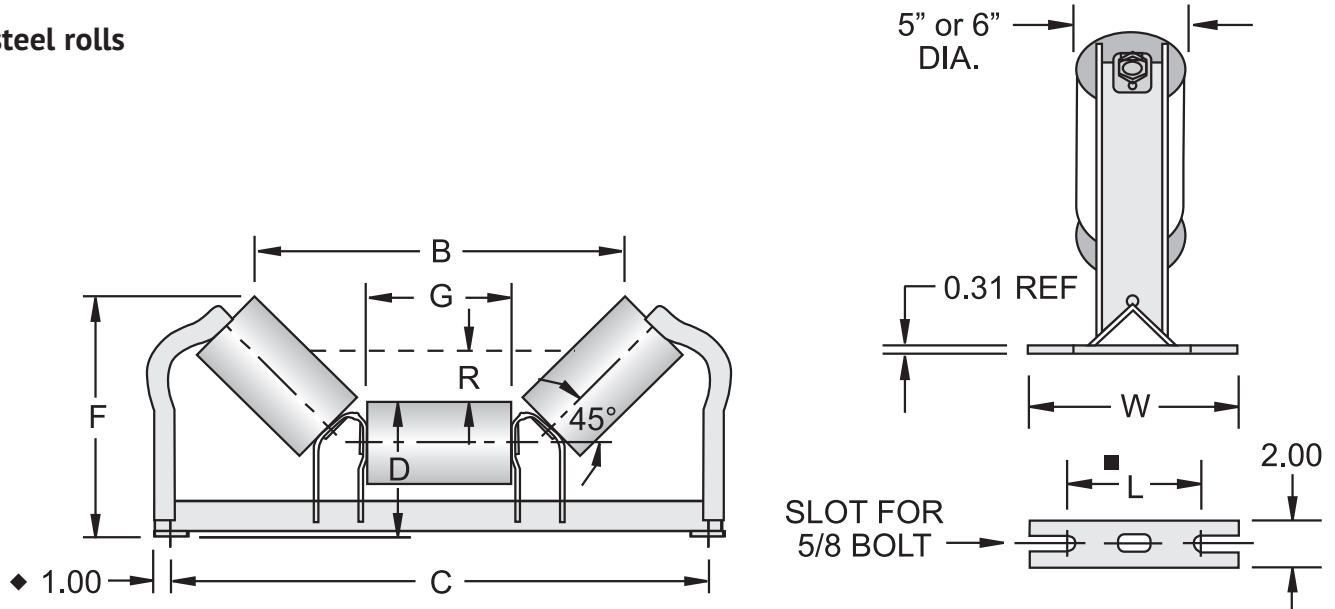

## CEMA C

Belt width, inches	Dia.	Idler number	Standard Base (Belt width + 9")		B	D	F	G	L	R**	W
			Idler weight, pounds	C							
18	5"	C2502-18	47	27.00	17.36	8.27	13.20	6.44	5.75	1.88	9.00
	6"	C2602-18	50	27.00	16.47	8.77	13.46	6.19	5.75	1.88	9.00
20	5"	C2502-20	49	29.00	19.17	8.27	13.73	7.19	5.75	2.12	9.00
	6"	C2602-20	53	29.00	18.28	8.77	13.99	6.94	5.75	2.12	9.00
24	5"	C2502-24	53	33.00	22.47	8.27	14.70	8.56	5.75	2.56	9.00
	6"	C2602-24	58	33.00	21.59	8.77	14.96	8.31	5.75	2.56	9.00
30	5"	C2502-30	61	39.00	27.30	8.63	16.47	10.56	5.75	3.31	9.00
	6"	C2602-30	66	39.00	26.42	9.13	16.74	10.31	5.75	3.31	9.00
36	5"	C2502-36	68	45.00	32.13	8.63	17.88	12.56	5.75	4.00	9.00
	6"	C2602-36	74	45.00	31.25	9.13	18.15	12.31	5.75	4.00	9.00
42	5"	C2502-42	88	51.00	37.73	9.00	19.90	14.88	5.75	4.62	9.00
	6"	C2602-42	94	51.00	36.85	9.50	20.16	14.63	5.75	4.62	9.00
48	5"	C2502-48	96	57.00	42.56	9.00	21.31	16.88	5.75	5.38	9.00
	6"	C2602-48	104	57.00	41.68	9.50	21.57	16.63	5.75	5.38	9.00
54	5"	C2502-54	104	63.00	47.53	9.00	22.77	18.94	5.75	6.06	9.00
	6"	C2602-54	111	63.00	46.65	9.50	23.03	18.69	5.75	6.06	9.00
60	5"	C2502-60	112	69.00	52.36	9.00	24.18	20.94	5.75	6.75	9.00
	6"	C2602-60	120	69.00	51.48	9.50	24.45	20.69	5.75	6.75	9.00

\*\* To top of discharge or bend pulleys, except tail pulley.

■ 7.5" bolt spacing recommended to permit adjustment.

◆ 1.69 for 18" belt width; 1.31 for 20" belt width.

# 45°

## Troughed Belt Training Idlers, Equal Length Rolls

### positive action type

(above deck mounting)

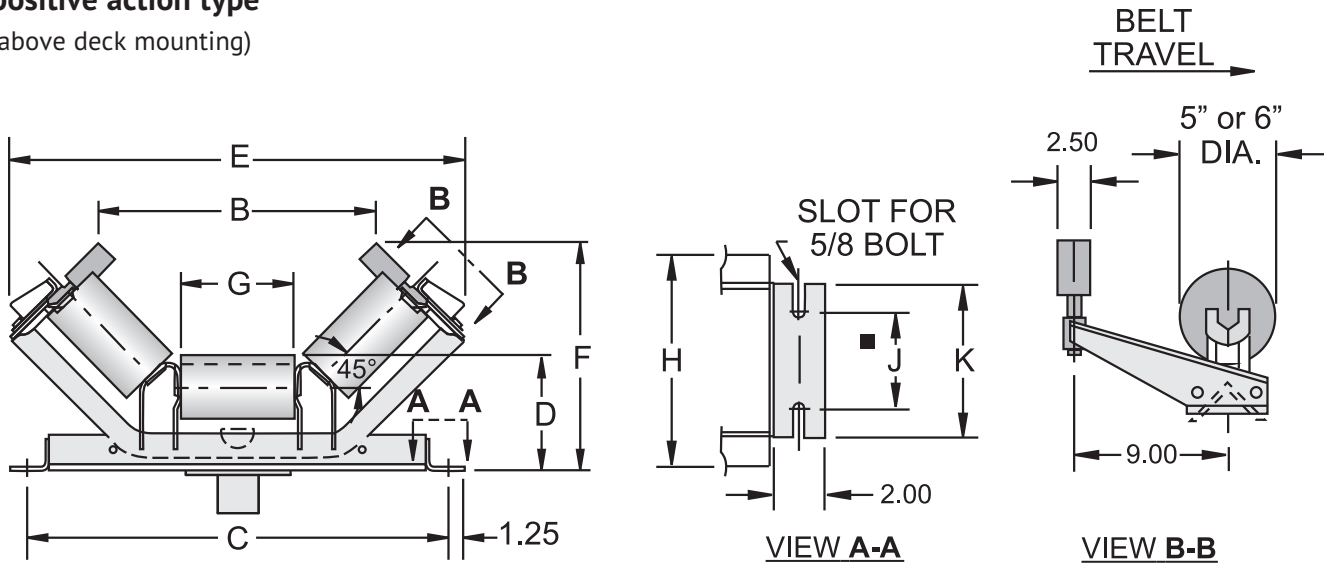

## CEMA C

Belt width, inches	Dia.	Idler number	Standard Base (Belt width + 9")		B	D	E	F	G	H	J	K
			Idler weight, pounds	C								
Inches												
18	5"	C2509-18	100	27.00	18.38	8.50	30.29	15.91	6.44	12.00	5.75	9.12
	6"	C2609-18	103	27.00	18.38	9.00	30.29	15.91	6.19	12.00	5.75	9.12
20	5"	C2509-20	104	29.00	20.17	8.50	32.07	16.45	7.19	12.00	5.75	9.12
	6"	C2609-20	108	29.00	20.17	9.00	32.07	16.45	6.94	12.00	5.75	9.12
24	5"	C2509-24	110	33.00	23.49	8.50	35.39	17.42	8.56	12.00	5.75	9.12
	6"	C2609-24	115	33.00	23.49	9.00	35.39	17.42	8.31	12.00	5.75	9.12
30	5"	C2509-30	131	39.00	28.32	8.75	40.22	19.09	10.56	14.00	5.75	10.00
	6"	C2609-30	137	39.00	28.32	9.25	40.22	19.09	10.31	14.00	5.75	10.00
36	5"	C2509-36	144	45.00	33.15	8.75	45.05	20.50	12.56	14.00	5.75	10.00
	6"	C2609-36	149	45.00	33.15	9.25	45.05	20.50	12.31	14.00	5.75	10.00
42	5"	C2509-42	196	51.00	38.73	9.12	50.63	22.52	14.88	16.00	5.75	12.00
	6"	C2609-42	202	51.00	38.73	9.62	50.63	22.52	14.63	16.00	5.75	12.00
48	5"	C2509-48	210	57.00	43.55	9.12	55.46	23.93	16.88	16.00	5.75	12.00
	6"	C2609-48	218	57.00	43.55	9.62	55.46	23.93	16.63	16.00	5.75	12.00
54	5"	C2509-54	226	63.00	48.53	9.12	60.43	25.38	18.94	16.00	5.75	12.00
	6"	C2609-54	233	63.00	48.53	9.62	60.43	25.38	18.69	16.00	5.75	12.00
60	5"	C2509-60	240	69.00	53.36	9.12	65.26	26.79	20.94	16.00	5.75	12.00
	6"	C2609-60	248	69.00	53.36	9.62	65.26	26.79	20.69	16.00	5.75	12.00

■ 7.5" bolt spacing recommended to permit adjustment.

# 45° Troughed Belt Training Idlers, Equal Length Rolls

actuating shoe type reversing belts

(above deck mounting)

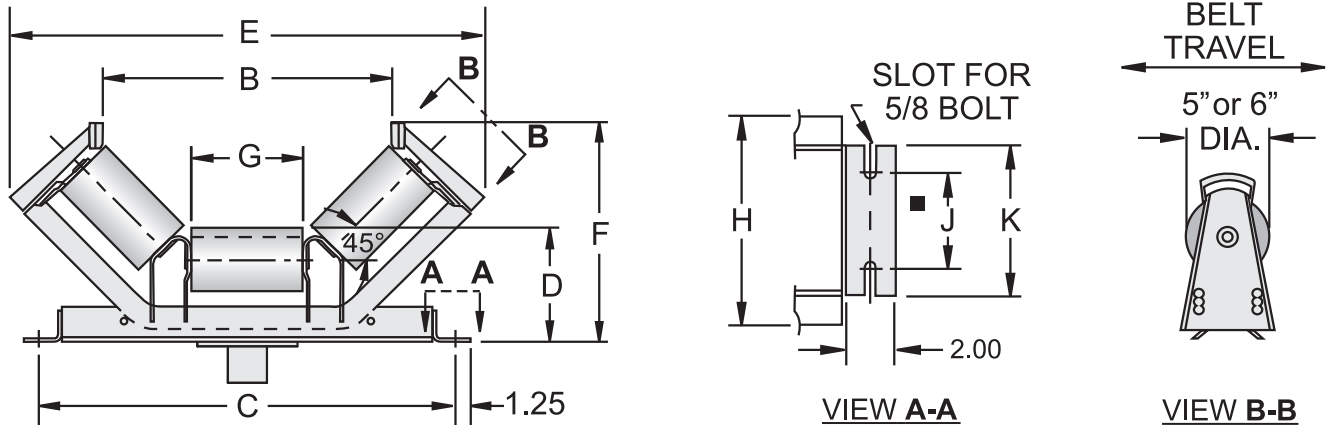

## CEMA C

Belt width, inches	Dia.	Idler number	Standard Base (Belt width + 9")		B	D	E	F	G	H	J	K
			Idler weight, pounds	C								
Inches												
18	5"	C2511-18	93	27.00	17.89	8.50	32.75	15.43	6.44	12.00	5.75	9.12
	6"	C2611-18	97	27.00	17.18	9.00	32.04	15.79	6.19	12.00	5.75	9.12
20	5"	C2511-20	97	29.00	19.68	8.50	34.53	15.97	7.19	12.00	5.75	9.12
	6"	C2611-20	102	29.00	18.97	9.00	33.83	16.33	6.94	12.00	5.75	9.12
24	5"	C2511-24	104	33.00	22.99	8.50	37.85	16.95	8.56	12.00	5.75	9.12
	6"	C2611-24	109	33.00	22.29	9.00	37.14	17.30	8.31	12.00	5.75	9.12
30	5"	C2511-30	125	39.00	27.82	8.75	42.68	18.61	10.56	14.00	5.75	10.00
	6"	C2611-30	130	39.00	27.12	9.25	41.97	18.96	10.31	14.00	5.75	10.00
36	5"	C2511-36	137	45.00	32.65	8.75	47.51	20.02	12.56	14.00	5.75	10.00
	6"	C2611-36	143	45.00	31.94	9.25	46.80	20.38	12.31	14.00	5.75	10.00
42	5"	C2511-42	189	51.00	38.23	9.12	53.09	22.03	14.88	16.00	5.75	12.00
	6"	C2611-42	195	51.00	37.52	9.62	52.38	22.39	14.63	16.00	5.75	12.00
48	5"	C2511-48	204	57.00	43.06	9.12	57.91	23.45	16.88	16.00	5.75	12.00
	6"	C2611-48	211	57.00	42.35	9.62	57.21	23.80	16.63	16.00	5.75	12.00
54	5"	C2511-54	219	63.00	48.03	9.12	62.89	24.90	18.94	16.00	5.75	12.00
	6"	C2611-54	227	63.00	47.33	9.62	62.18	25.26	18.69	16.00	5.75	12.00
60	5"	C2511-60	234	69.00	52.86	9.12	67.72	26.32	20.94	16.00	5.75	12.00
	6"	C2611-60	242	69.00	52.15	9.62	67.10	26.67	20.69	16.00	5.75	12.00

■ 7.5" bolt spacing recommended to permit adjustment.

# Variable Troughed Belt Idlers 10° - 35° Adjustment

steel rolls

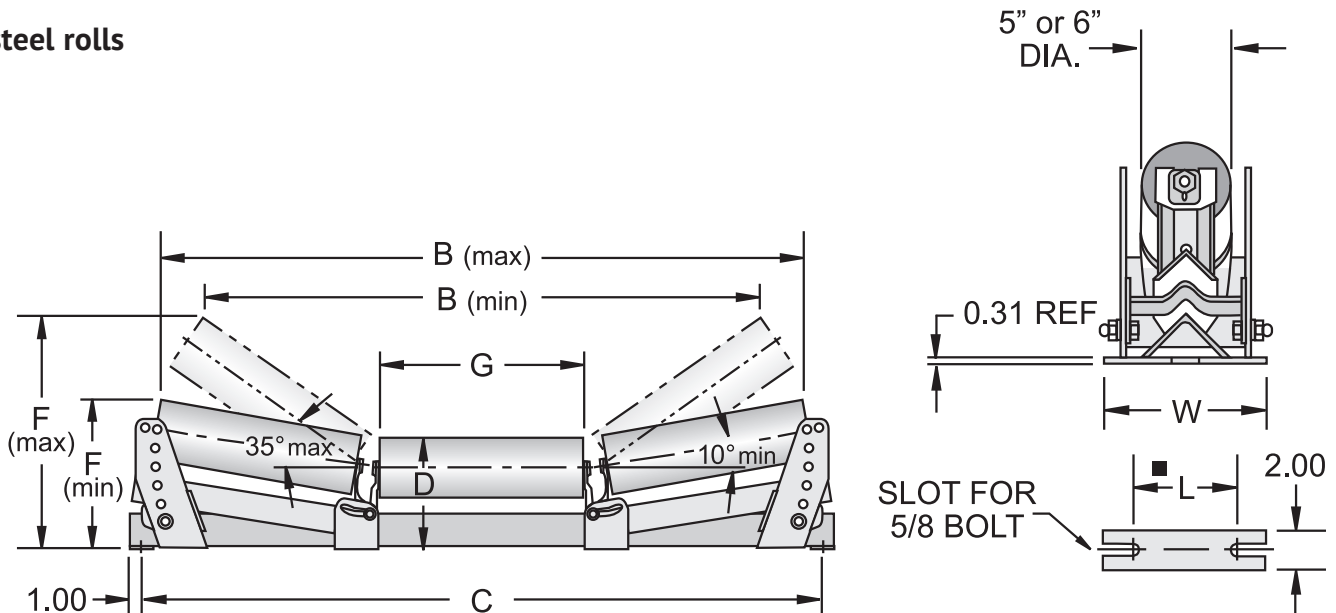

## CEMA C

Belt width, inches	Dia.	Idler number	Standard Base (Belt width + 9")		B		□	F		G	L	W
			Idler weight, pounds	C	MIN.	MAX.		D	MIN.			
							Inches					
24	5"	C2506-24	97	33.00	24.52	28.88	9.31	11.06	14.67	8.56	5.75	9.00
	6"	C2606-24	108	33.00	23.75	28.47	9.81	11.54	15.00	8.31	5.75	9.00
30	5"	C2506-30	106	39.00	29.77	34.79	9.31	11.41	15.81	10.56	5.75	9.00
	6"	C2606-30	113	39.00	28.99	34.38	9.81	11.89	16.14	10.31	5.75	9.00
36	5"	C2506-36	120	45.00	35.02	40.71	9.31	11.76	16.96	12.56	5.75	9.00
	6"	C2606-36	126	45.00	34.25	40.29	9.81	12.24	17.29	12.31	5.75	9.00
42	5"	C2506-42	133	51.00	41.11	47.57	9.31	12.17	18.28	14.88	5.75	9.00
	6"	C2606-42	137	51.00	40.34	47.15	9.81	12.64	18.62	14.63	5.75	9.00
48	5"	C2506-48	148	57.00	46.38	53.49	9.31	12.52	19.43	16.88	5.75	9.00
	6"	C2606-48	154	57.00	45.60	53.08	9.81	12.99	19.77	16.63	5.75	9.00
54	5"	C2506-54	156	63.00	51.81	59.61	9.31	12.88	20.61	18.94	5.75	9.00
	6"	C2606-54	162	63.00	51.03	59.19	9.81	13.35	20.95	18.69	5.75	9.00
60	5"	C2506-60	167	69.00	57.08	65.54	9.31	13.22	21.76	20.94	5.75	9.00
	6"	C2606-60	175	69.00	56.30	65.12	9.81	13.69	22.10	20.69	5.75	9.00

- 7.5" bolt spacing recommended to permit adjustment.
- Shim as required to contact belt and support load.

# Return Belt Idlers

## steel rolls

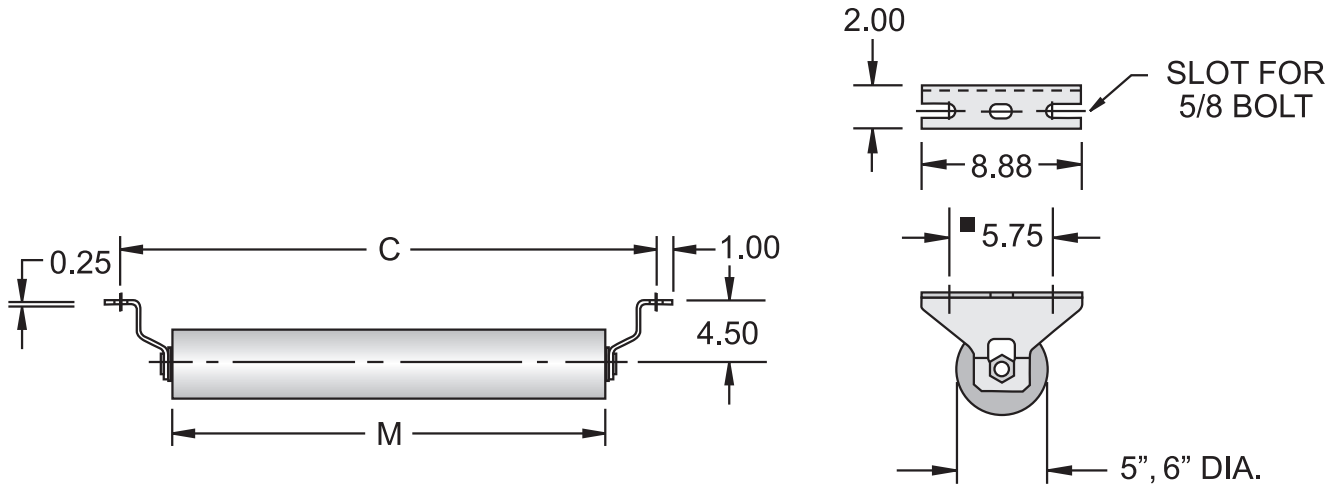

# CEMA C

Belt width, inches	Dia.	Idler number	Idler weight, pounds	Standard Base (Belt width + 9")	
				C	M
				Inches	
18	5"	C2517-18	25	27.00	20.63
	6"	C2617-18	28	27.00	20.38
20	5"	C2517-20	26	29.00	22.63
	6"	C2617-20	30	29.00	22.38
24	5"	C2517-24	29	33.00	26.63
	6"	C2617-24	32	33.00	26.38
30	5"	C2517-30	33	39.00	32.63
	6"	C2617-30	37	39.00	32.38
36	5"	C2517-36	37	45.00	38.63
	6"	C2617-36	41	45.00	38.38
42	5"	C2517-42	44	51.00	44.63
	6"	C2617-42	50	51.00	44.38
48	5"	C2517-48	49	57.00	50.63
	6"	C2617-48	55	57.00	50.38
54	5"	C2517-54	53	63.00	56.63
	6"	C2617-54	60	63.00	56.38
60	5"	C2517-60	58	69.00	62.63
	6"	C2617-60	65	69.00	62.38

■ 7.50" bolt spacing recommended to permit adjustment.

# Return Belt Training Idlers

steel rolls, positive action type

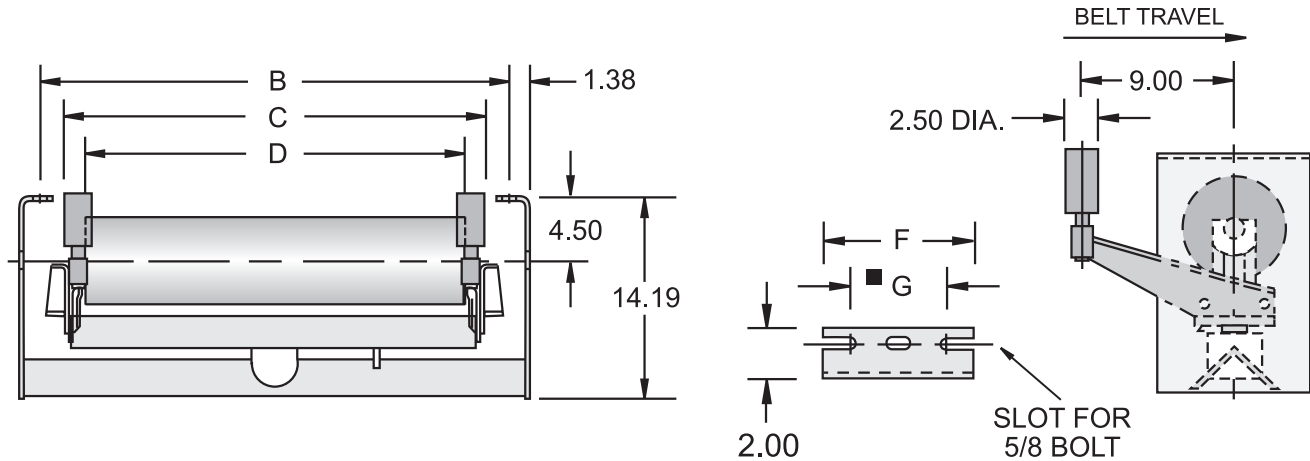

## CEMA C

Belt width, inches	Dia.	Idler number	Standard Base (Belt width + 9")		C	D	G	F
			Idler weight, pounds	B				
18	5"	C2520-18	101	27.00	24.91	20.63	5.75	9.00
	6"	C2620-18	104	27.00	24.91	20.38	5.75	9.00
20	5"	C2520-20	105	29.00	26.91	22.63	5.75	9.00
	6"	C2620-20	108	29.00	26.91	22.38	5.75	9.00
24	5"	C2520-24	113	33.00	30.91	26.63	5.75	9.00
	6"	C2620-24	116	33.00	30.91	26.38	5.75	9.00
30	5"	C2520-30	134	39.00	36.91	32.63	5.75	9.00
	6"	C2620-30	138	39.00	36.91	32.38	5.75	9.00
36	5"	C2520-36	147	45.00	42.91	38.63	5.75	9.00
	6"	C2620-36	152	45.00	42.91	38.38	5.75	9.00
42	5"	C2520-42	177	51.00	48.91	44.63	5.75	9.00
	6"	C2620-42	182	51.00	48.91	44.38	5.75	9.00
48	5"	C2520-48	193	57.00	54.91	50.63	5.75	9.00
	6"	C2620-48	199	57.00	54.91	50.38	5.75	9.00
54	5"	C2520-54	211	63.00	60.91	56.63	6.75	10.00
	6"	C2620-54	217	63.00	60.91	56.38	6.75	10.00
60	5"	C2520-60	227	69.00	66.91	62.63	6.75	10.00
	6"	C2620-60	234	69.00	66.91	62.38	6.75	10.00

■ 7.5" bolt spacing recommended to permit adjustment. (8.5" for 54" belt width and above).

# Return Belt Training Idlers

steel rolls, actuating shoe type, reversing belts

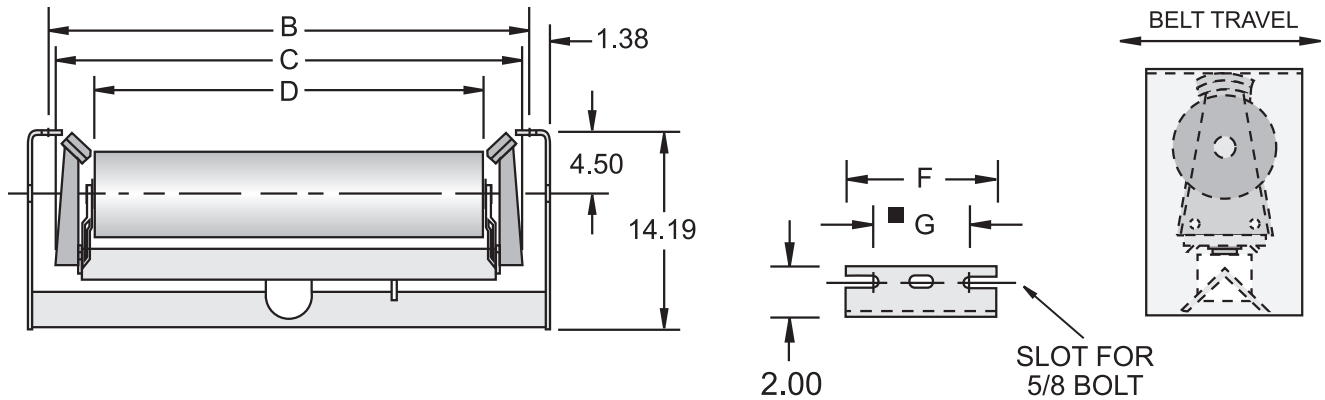

## CEMA C

Belt width, inches	Dia.	Idler number	Standard Base (Belt width + 9")		C	D	G	F
			Idler weight, pounds	B				
18	5"	C2526-18	97	27.00	26.17	20.63	5.75	9.00
	6"	C2626-18	100	27.00	26.17	20.38	5.75	9.00
20	5"	C2526-20	101	29.00	28.17	22.63	5.75	9.00
	6"	C2626-20	104	29.00	28.17	22.38	5.75	9.00
24	5"	C2526-24	109	33.00	32.17	26.63	5.75	9.00
	6"	C2626-24	112	33.00	32.17	26.38	5.75	9.00
30	5"	C2526-30	130	39.00	38.17	32.63	5.75	9.00
	6"	C2626-30	134	39.00	38.17	32.38	5.75	9.00
36	5"	C2526-36	143	45.00	44.17	38.63	5.75	9.00
	6"	C2626-36	148	45.00	44.17	38.38	5.75	9.00
42	5"	C2526-42	173	51.00	50.17	44.63	5.75	9.00
	6"	C2626-42	178	51.00	50.17	44.38	5.75	9.00
48	5"	C2526-48	189	57.00	56.17	50.63	5.75	9.00
	6"	C2626-48	195	57.00	56.17	50.38	5.75	9.00
54	5"	C2526-54	207	63.00	62.17	56.63	6.75	10.00
	6"	C2626-54	213	63.00	62.17	56.38	6.75	10.00
60	5"	C2526-60	223	69.00	68.17	62.63	6.75	10.00
	6"	C2626-60	230	69.00	68.17	62.38	6.75	10.00

■ 7.5" bolt spacing recommended to permit adjustment. (8.5" for 54" belt width and above).





# Ordering Replacement Rolls

Below are the part numbers to reference when ordering sealed replacement rolls for CEMA Series C2000. Frame is not included.

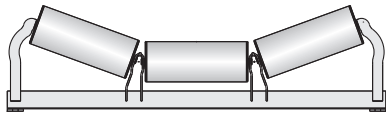

The following part numbers fit

**5"** diameter steel troughing rolls for C2501, C2502, C2506, C2507, C2508, C2509, C2511, C2528, C2532 and C2537 idlers

## C2000 Replacement Rolls

Belt Width	Part Number
18	1726-258-A
20	1726-258-B
24	1726-258-C
30	1726-258-D
36	1726-258-E
42	1726-258-F
48	1726-258-G
54	1726-258-H
60	1726-258-J

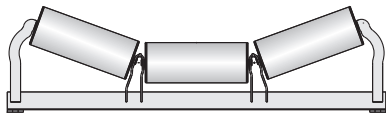

The following part numbers fit

**6"** diameter steel troughing rolls for C2601, C2602, C2606, C2607, C2608, C2609, C2611, C2628, C2632 and C2637 idlers

## C2000 Replacement Rolls

Belt Width	Part Number
18	1726-259-A
20	1726-259-B
24	1726-259-C
30	1726-259-D
36	1726-259-E
42	1726-259-F
48	1726-259-G
54	1726-259-H
60	1726-259-J

# Ordering Replacement Rolls

Below are the part numbers to reference when ordering sealed replacement rolls for CEMA Series C2000. Frame is not included.



The following part numbers fit

**5”** diameter steel return/carrying rolls for C2526, C2517 and C2520 idlers

## C2000 Replacement Rolls

Belt Width	Part Number
18	1726-258-AA
20	1726-258-AB
24	1726-258-AC
30	1726-258-AD
36	1726-258-AE
42	1726-258-AF
48	1726-258-AG
54	1726-258-AH
60	1726-258-AJ



The following part numbers fit

**6”** diameter steel return/carrying rolls for C2626, C2617 and C2620 idlers

## C2000 Replacement Rolls

Belt Width	Part Number
18	1726-259-AA
20	1726-259-AB
24	1726-259-AC
30	1726-259-AD
36	1726-259-AE
42	1726-259-AF
48	1726-259-AG
54	1726-259-AH
60	1726-259-AJ

# Ordering Replacement Rolls

(FOR C2000 IDLERS PURCHASED 1995-2013)

Below are the part numbers to reference when ordering sealed replacement rolls for CEMA Series C2000.  
Frame is not included.

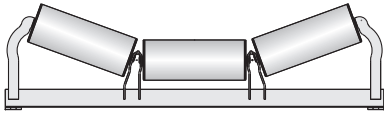

The following part numbers fit

**5"** diameter steel troughing rolls for C2501, C2502, C2506, C2507, C2508, C2509, C2511, C2528, C2532 and C2537 idlers

## C2000 Replacement Rolls

Belt Width	Part Number
24	1726-116-B
30	1726-116-C
36	1726-116-D
42	1726-116-E
48	1726-116-F

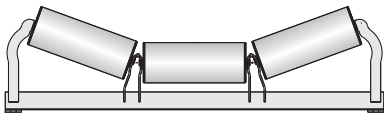

The following part numbers fit

**6"** diameter steel troughing rolls for C2601, C2602, C2606, C2607, C2608, C2609, C2611, C2628, C2632 and C2637 idlers

## C2000 Replacement Rolls

Belt Width	Part Number
24	1726-118-B
30	1726-118-C
36	1726-118-D
42	1726-118-E
48	1726-118-F

# Ordering Replacement Rolls

(FOR C2000 IDLERS PURCHASED 1995-2013)

Below are the part numbers to reference when ordering sealed replacement rolls for CEMA Series C2000.  
Frame is not included.



The following part numbers fit  
**5”** diameter steel return/carrying rolls for C2526, C2517 and C2520 idlers

## C2000 Replacement Rolls

Belt Width	Part Number
24	1726-116-AB
30	1726-116-AC
36	1726-116-AD
42	1726-116-AE
48	1726-116-AF



The following part numbers fit  
**6”** diameter steel return/carrying rolls for C2626, C2617 and C2620 idlers

## C2000 Replacement Rolls

Belt Width	Part Number
24	1726-118-AB
30	1726-118-AC
36	1726-118-AD
42	1726-118-AE
48	1726-118-AF

# CEMA Series C3000 and D3000 Idlers

## Bearings

- Precision tapered roller bearings with modified geometry; LM11900 with  $\frac{3}{4}$ " bore
- Bearings/shaft are designed to accommodate bearing misalignment under fully rated loads
- L10 bearing life > 60,000 hrs @ 500 rpm, exceeds load ratings of 6306 ball bearing products

## Frames

- Inverted angle frame base with slotted foot straps to ensure quick, easy mounting and alignment
- Heavy-duty, die-formed, steel end brackets are contoured for generous clearance to safeguard against spilled materials becoming jammed and impeding the rotation of the rollers
- All idler frames are welded in accordance with AWS D1.1 specifications for structural welds

## Seal

- The outer adjusting nuts are zinc plated, machined steel, to minimize corrosion
- Rubber triple lip contact seal paired with a nylon deflector nut with integrated labyrinth seal for robust, redundant sealing capability
- Seal works well in dusty conditions and wash down environments

## Coatings

- Frames and rolls are powder-coated (see page 155 for details)
- Assembly hardware is electro-zinc plated

## CEMA

- Idlers meet or exceed CEMA requirements for rugged, continuous material handling
- Multiple belt widths and models available to meet your needs

## Roll Thickness

- 5" diameter = 9 ga (0.148)
- 6" diameter = 8 ga (0.165)
- 4" diameter rolls are available
- $\frac{1}{4}$ " thick steel rolls are optional

## Testing Capabilities

- Load rating
- Seals
- Roll concentricity
- Roll resistance
- Roll imbalance
- Water resistance

One of the following letter suffixes may sometimes be necessary to complete an idler description:

**P** - Polyethylene rolls

**R** - Rubber lagged impact or rubber tread rolls

**RC** - Rubber lagged impact center roll

**W** - Scale idler

**U** - Urethane coated or lagged rolls

**GAL** - Galvanized frame

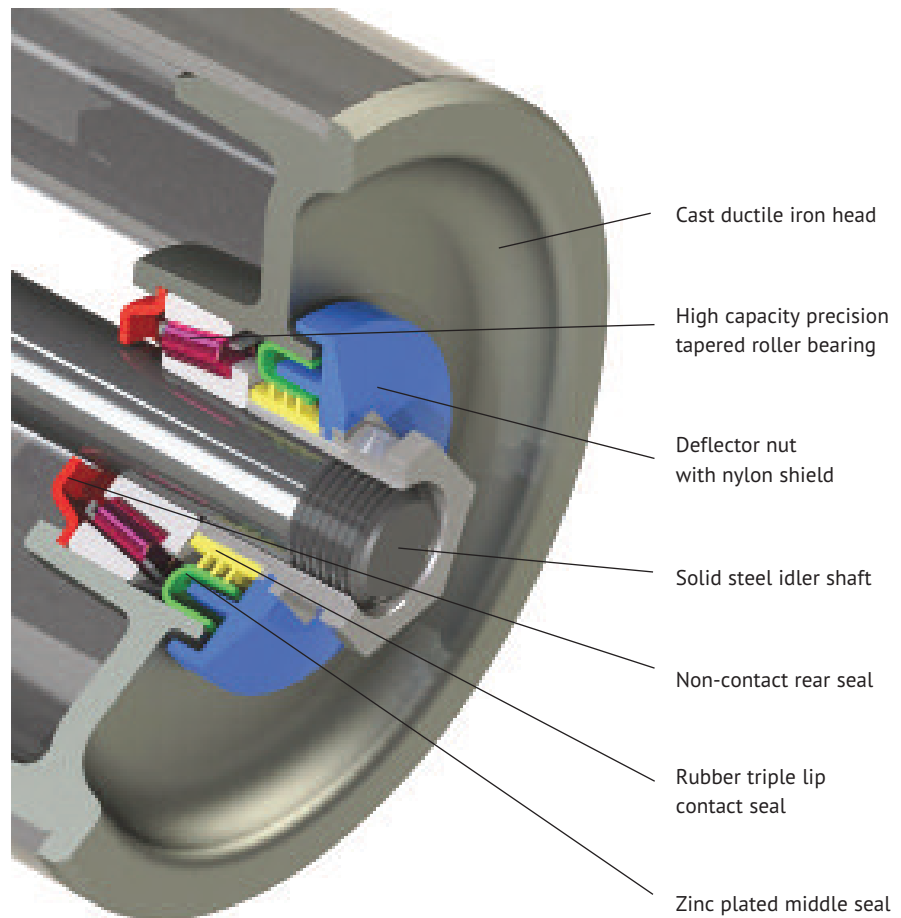

## Carrying Idler Types

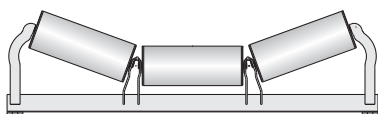

**Troughed belt idlers** for general carrying service are available with roll inclinations of 20°, 35°, and 45°.



**Flat belt idlers** are used for handling bulk materials such as prepared foundry sand and undelinted cotton seed where it is desirable to plow off material at one or more intermediate points along the conveyor. Also used for pulpwood logs, packages, picking and sorting conveyors. Live shaft type is available for heavy duty service.

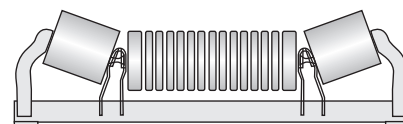

**Troughed belt picking and feeder conveyor idlers** carry the load in a wide, thin layer where picking and sorting are required or where a shallow bed of material is required to minimize degradation. Standard design features rubber cushion center roll and steel end rolls. Also available with all steel or all rubber cushion rolls.

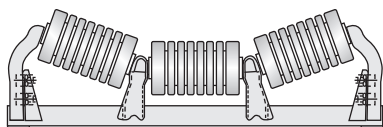

**Troughed belt rubber cushion idlers** protect the belt by absorbing impacts at loading and transfer points. Design features include removable end brackets on 35° and 45° idlers.

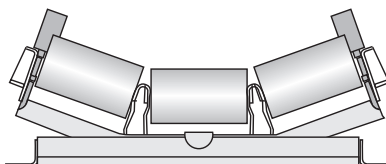

**Troughed belt training idlers** automatically train belts and protect belt edges from damage caused by misalignment. Positive action type available for belts operating in one direction, and actuating shoe type available for two-directional operation (reversing).



**Flat belt rubber cushion idlers** protect the belt by absorbing impacts at loading and transfer points. Live shaft type is for heavy-duty service.

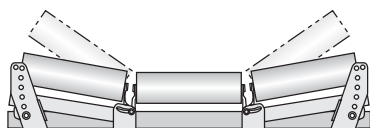

**Variable troughed belt idlers** placed between the final troughing idler and the head pulley, support the belt during its transition from a concave to a flat contour. The end rolls can be adjusted vertically to match the changing contour of the belt during this critical period of transition.

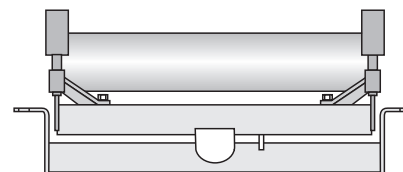

**Flat belt training idlers** automatically train belts and protect belt edges from damage caused by misalignment. Available in the positive action type for belts operating in one direction.

## Return Idler Types



**Return belt idlers** carry the empty belt on the return run.

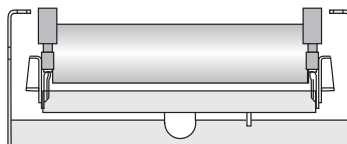

**Return belt training idlers** train the belt and protect its edges from damage caused by misalignment. Positive action type for belts operating in one direction. Actuating shoe type for reversing belts.

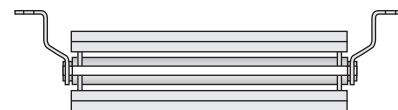

**Return belt beater idlers** remove excessive amounts of tenacious materials that adhere to the belt.

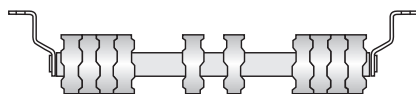

**Return belt rubber tread idlers** are used when wet or sticky materials tend to cling to the belt, where corrosion resistance is required or where chemical reaction to iron or steel is involved. Available with urethane treads.

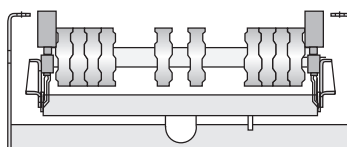

**Return rubber tread training idlers** train the belt and protect its edges from damage caused by misalignment. Used when wet or sticky materials tend to cling to the belt, where corrosion resistance is required or where chemical reaction to iron or steel is involved. Positive action type for belts operating in one direction. Actuating shoe type for reversing belts.

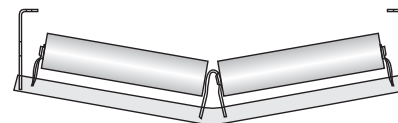

**Rigid frame v-return idlers** provide a means of training the return belt, with the added benefit of additional carrying load capacity. Rigid v-returns can be adjusted using slotted bolt holes in the end brackets of the frame to aid in proper belt training.

## CEMA C / D idlers of every type to meet your specific needs...

Syntron Material Handling Model Number	Page	CEMA C	CEMA D	10°	15°	20°	35°	45°	10-35° Variable
3501S / 3601S	54	18" - 60"	24" - 72"			●			
3502S / 3602S	62	20" - 60"	24" - 72"					●	
3504S / 3604S	55	18" - 60"	24" - 72"			●			
3505S / 3605S	66	24" - 60"	30" - 72"			●			
3505RS / 3605RS	67	24" - 60"	30" - 72"			●			
3505RCS / 3605RCS	67	24" - 60"	30" - 72"			●			
3506S / 3606S	68	24" - 60"	24" - 72"						●
3507S / 3607S	56	18" - 60"	24" - 72"			●			
3508S / 3608S	57	18" - 60"	24" - 72"			●			
3509S / 3609S	64	18" - 60"	24" - 72"					●	
3511S / 3611S	65	18" - 60"	24" - 72"					●	
3513S / 3613S	69	18" - 48"	24" - 78"						
3513LS / 3613LS	70	18" - 60"	N/A						
3514S / 3614S	73	18" - 48"	24" - 72"						
3515S / 3615S	71	18" - 48"	24" - 72"						
3516S / 3616S	72	18" - 60"	N/A						
3517S / 3617S	75	18" - 48"	24" - 72"						
3518S / 3618S	74	18" - 48"	24" - 72"						
3619S	76	18" - 48"	24" - 60"						
3520S / 3620S	77	18" - 48"	24" - 72"						
3521S / 3621S	78	18" - 48"	24" - 72"						
3523S / 3623S	63	20" - 60"	24" - 72"					●	
3526S / 3626S	79	18" - 48"	24" - 72"						
3527S / 3627S	80	18" - 48"	24" - 72"						
3528S / 3628S	58	18" - 60"	24" - 72"				●		
3530S / 3630S	59	18" - 60"	24" - 72"				●		
3532S / 3632S	60	18" - 60"	24" - 72"				●		
3537S / 3637S	61	18" - 60"	24" - 72"				●		
3565S / 3665S	81	24" - 66"	36" - 78"	●					
3566S / 3666S	82	24" - 66"	36" - 78"		●				
3668S	83	24" - 66"	36" - 78"	●					
3669S	84	24" - 66"	36" - 78"		●				



CAUTION: Link-Belt Conveyor Idlers must be installed, operated and maintained in accordance with accompanying Syntron Material Handling Service Instructions. Failure to follow these instructions can result in serious personal injury, property damage or both.

Syntron Material Handling Service Instructions are available for download at [www.syntronmh.com](http://www.syntronmh.com).



Flat Carrying	Return	V Return	Training Positive	Training Reversing	Picking & Feeding	Live Shaft	Steel	Rubber Cushion (Impact)	Rubber Tread
							●		
							●		
								●	
					●		●		
				●				●	
					●		● (ends)	● (center)	
							●		
			●				●		
				●			●		
			●				●		
				●			●		
●							●		
●						●	●		
●			●				●		
								●	
●						●		●	
	●						●		
	●								●
●									
	●		●				●		
	●		●						●
								●	
	●			●			●		
	●			●					●
							●		
			●				●		
				●			●		
		●					●		
		●					●		
		●							●
		●							●

# 20° Troughed Belt Idlers, Equal Length Rolls

steel rolls

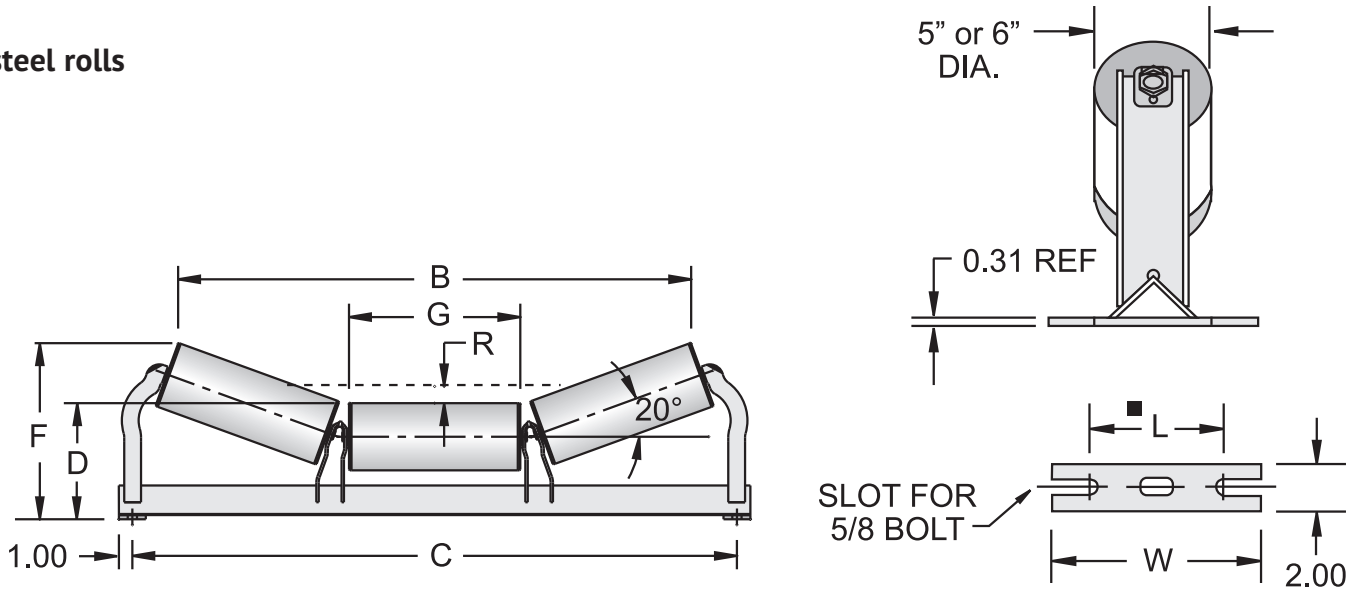

## CEMA C / D

Belt width, inches	Dia.	● Idler number	Standard Base (Belt width + 9")		Wide Base (Belt width + 15")		B	D	F	G	L	R**	W
			Idler weight, pounds	C	Idler weight, pounds	C							
Inches													
18	5"	C3501S-18	43	27.00	45	33.00	20.56	8.25	10.69	6.69	5.75	0.94	9.00
	6"	C3601S-18	52	27.00	54	33.00	20.25	8.75	11.12	6.69	5.75	0.94	9.00
20	5"	C3501S-20	45	29.00	47	35.00	22.75	8.25	10.94	7.44	5.75	1.00	9.00
	6"	C3601S-20	57	29.00	59	35.00	22.38	8.75	11.31	7.44	5.75	1.00	9.00
24	5"	3501S-24	52	33.00	54	39.00	26.69	8.25	11.38	8.81	5.75	1.25	9.00
	6"	3601S-24	66	33.00	68	39.00	26.31	8.75	11.88	8.81	5.75	1.25	9.00
30	5"	3501S-30	60	39.00	62	45.00	32.44	8.62	12.44	10.81	5.75	1.62	9.00
	6"	3601S-30	69	39.00	71	45.00	32.12	9.12	12.94	10.81	5.75	1.62	9.00
36	5"	3501S-36	70	45.00	72	51.00	38.19	8.62	13.12	12.81	5.75	1.94	9.00
	6"	3601S-36	81	45.00	83	51.00	37.88	9.12	13.62	12.81	5.75	1.94	9.00
42	5"	3501S-42	89	51.00	92	57.00	44.88	9.00	14.31	15.12	5.75	2.25	9.00
	6"	3601S-42	99	51.00	102	57.00	44.56	9.50	14.75	15.12	5.75	2.25	9.00
48	5"	3501S-48	97	57.00	100	63.00	50.62	9.00	15.00	17.12	5.75	2.62	9.00
	6"	3601S-48	110	57.00	113	63.00	50.31	9.50	15.44	17.12	5.75	2.62	9.00
54	5"	3501S-54	105	63.00	108	69.00	56.56	9.00	15.69	19.19	5.75	2.94	9.00
	6"	3601S-54	117	63.00	120	69.00	56.25	9.50	16.19	19.19	5.75	2.94	9.00
60	5"	3501S-60	118	69.00	121	75.00	62.31	9.00	16.38	21.19	5.75	3.25	9.00
	6"	3601S-60	133	69.00	136	75.00	62.00	9.50	16.81	21.19	5.75	3.25	9.00
72	5"	D3501S-72	143	81.00	147	87.00	73.88	9.38	18.12	25.19	8.25	3.94	11.50
	6"	D3601S-72	158	81.00	162	87.00	73.50	9.88	18.56	25.19	8.25	3.94	11.50

\*\* To top of discharge or bend pulleys, except foot pulley.

■ Bolt spacing recommended to permit adjustment is (L + 1.75"). Example: If "L" = 5.75" then (5.75" + 1.75" = 7.5" bolt spacing).

● CEMA C or D are available in belt widths of 24" - 60".

# 20° Troughed Belt Idlers, Equal Length Rolls

rubber cushion rolls (impact)

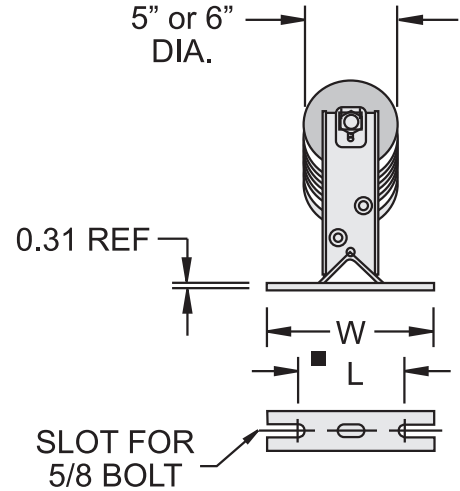
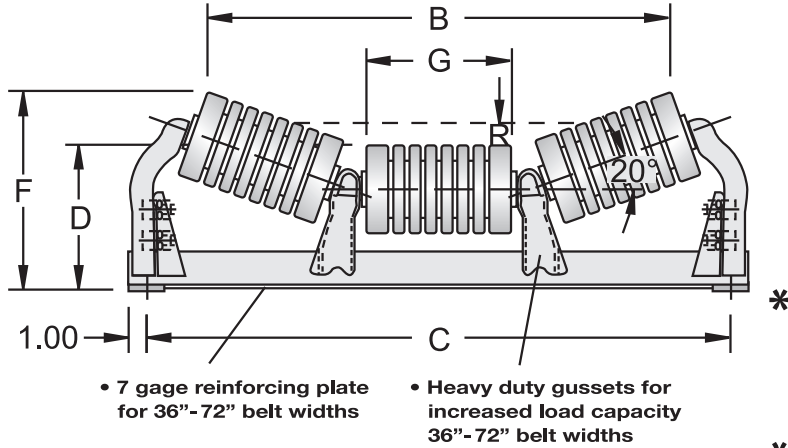

\* Demountable end bracket supplied for 36"- 72" belt widths

## CEMA C / D

Belt width, inches	Dia.	● Idler number	Standard Base (Belt width + 9")		Wide Base (Belt width + 15")		B	D	F	G	L	R**	W
			Idler weight, pounds	C	Idler weight, pounds	C							
18	5"	C3504S-18	44	27.00	46	33.00	20.00	8.25	10.50	6.06	5.75	0.88	9.00
	6"	C3604S-18	51	27.00	53	33.00	19.62	8.75	11.00	6.06	5.75	0.88	9.00
20	5"	C3504S-20	49	29.00	50	35.00	22.00	8.25	10.81	6.81	5.75	1.06	9.00
	6"	C3604S-20	58	29.00	60	35.00	21.81	8.75	11.25	6.81	5.75	1.06	9.00
24	5"	3504S-24	54	33.00	56	39.00	26.00	8.25	11.25	8.19	5.75	1.25	9.00
	6"	3604S-24	63	33.00	64	39.00	25.75	8.75	11.75	8.19	5.75	1.25	9.00
30	5"	3504S-30	64	39.00	66	45.00	31.88	8.62	12.38	10.19	5.75	1.62	9.00
	6"	3604S-30	70	39.00	72	45.00	31.56	9.12	12.81	10.19	5.75	1.62	9.00
36	5"	3504S-36	75	45.00	77	51.00	37.62	8.62	13.00	12.19	5.75	1.94	9.00
	6"	3604S-36	86	45.00	88	51.00	37.25	9.12	13.44	12.19	5.75	1.94	9.00
42	5"	3504S-42	96	51.00	99	57.00	44.25	9.00	14.12	14.50	5.75	2.25	9.00
	6"	3604S-42	108	51.00	111	57.00	43.94	9.50	14.62	14.50	5.75	2.25	9.00
48	5"	3504S-48	106	57.00	109	63.00	50.00	9.00	14.81	16.50	5.75	2.56	9.00
	6"	3604S-48	121	57.00	124	63.00	49.50	9.50	15.31	16.50	5.75	2.56	9.00
54	5"	3504S-54	119	63.00	121	69.00	56.00	9.00	15.56	18.56	5.75	3.00	9.00
	6"	3604S-54	135	63.00	138	69.00	55.62	9.50	16.00	18.56	5.75	3.00	9.00
60	5"	3504S-60	129	69.00	131	75.00	61.75	9.00	16.25	20.56	5.75	3.25	9.00
	6"	3604S-60	148	69.00	151	75.00	61.38	9.50	16.69	20.56	5.75	3.25	9.00
72	5"	D3504S-72	152	81.00	157	87.00	73.25	9.38	17.94	24.56	8.25	3.94	11.50
	6"	D3604S-72	171	81.00	176	87.00	72.94	9.88	18.44	24.56	8.25	3.94	11.50

\*\* To top of discharge or bend pulleys, except foot pulley.

■ Bolt spacing recommended to permit adjustment is (L + 1.75"). Example: If "L" = 5.75" then (5.75" + 1.75" = 7.5" bolt spacing).

● CEMA C or D are available in belt widths of 24" - 60".

# 20° Troughed Belt Training Idlers, Equal Length Rolls

**positive action type**  
(above deck mounting)

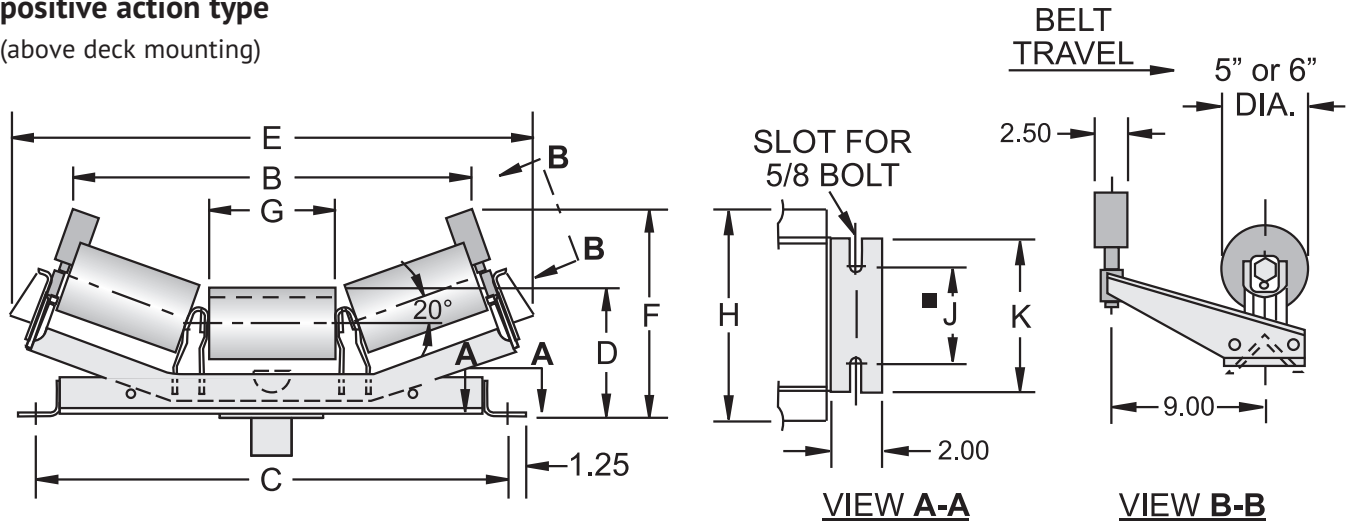

## CEMA C / D

Belt width, inches	Dia.	● Idler number	Standard Base (Belt width + 9")		Wide Base (Belt width + 15")		B	D	E	F	G	H	J	K
			Idler weight, pounds	C	Idler weight, pounds	C								
Inches														
18	5"	C3507S-18	94	27.00	96	33.00	22.64	9.00	30.38	14.26	6.69	11.50	5.75	9.00
	6"	C3607S-18	103	27.00	104	33.00	22.64	9.50	30.38	14.26	6.69	11.50	5.75	9.00
20	5"	C3507S-20	99	29.00	101	35.00	24.80	9.00	32.56	14.52	7.44	11.50	5.75	9.00
	6"	C3607S-20	111	29.00	113	35.00	24.80	9.50	32.56	14.52	7.44	11.50	5.75	9.00
24	5"	3507S-24	110	33.00	112	39.00	28.74	9.00	36.50	14.99	8.81	11.50	5.75	9.00
	6"	3607S-24	124	33.00	126	39.00	28.74	9.50	36.50	14.99	8.81	11.50	5.75	9.00
30	5"	3507S-30	125	39.00	127	45.00	34.50	9.38	42.25	16.05	10.81	12.50	5.75	9.00
	6"	3607S-30	135	39.00	137	45.00	34.50	9.88	42.25	16.05	10.81	12.50	5.75	9.00
36	5"	3507S-36	141	45.00	143	51.00	40.26	9.38	48.00	16.73	12.81	12.50	5.75	9.00
	6"	3607S-36	152	45.00	153	51.00	40.26	9.88	48.00	16.73	12.81	12.50	5.75	9.00
42	5"	3507S-42	168	51.00	170	57.00	46.91	9.75	54.69	17.89	15.12	12.50	5.75	9.00
	6"	3607S-42	178	51.00	180	57.00	46.91	10.25	54.69	17.89	15.12	12.50	5.75	9.00
48	5"	3507S-48	183	57.00	185	63.00	52.67	9.75	60.44	18.58	17.12	12.50	5.75	9.00
	6"	3607S-48	195	57.00	197	63.00	52.67	10.25	60.44	18.58	17.12	12.50	5.75	9.00
54	5"	3507S-54	198	63.00	200	69.00	58.63	9.75	66.38	19.29	19.19	12.50	5.75	9.00
	6"	3607S-54	209	63.00	211	69.00	58.63	10.25	66.38	19.29	19.19	12.50	5.75	9.00
60	5"	3507S-60	216	69.00	218	75.00	64.39	9.75	72.12	19.97	21.19	12.50	5.75	9.00
	6"	3607S-60	231	69.00	233	75.00	64.39	10.25	72.12	19.97	21.19	12.50	5.75	9.00
72	5"	D3507S-72	242	81.00	245	87.00	75.91	10.00	83.62	21.59	25.19	15.50	8.50	13.00
	6"	D3607S-72	256	81.00	260	87.00	75.91	10.50	83.62	21.59	25.19	15.50	8.50	13.00

\*\* Elevation above adjacent idlers.

■ Bolt spacing recommended to permit adjustment is (J + 1.75").  
Example: If "J" = 5.75" then (5.75" + 1.75" = 7.5" bolt spacing).

● 1/4" thick rubber or urethane coated rolls, optional.

● CEMA C or D are available in belt widths of 24" - 60".

# 20° Troughed Belt Training Idlers, Equal Length Rolls

## actuating shoe type reversing belts

(above deck mounting)

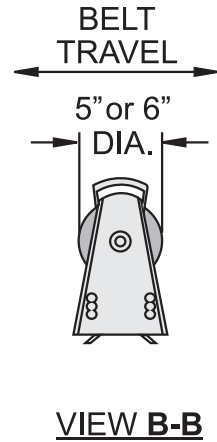
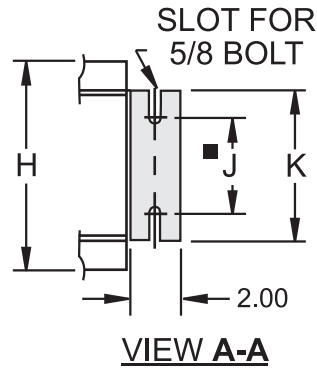
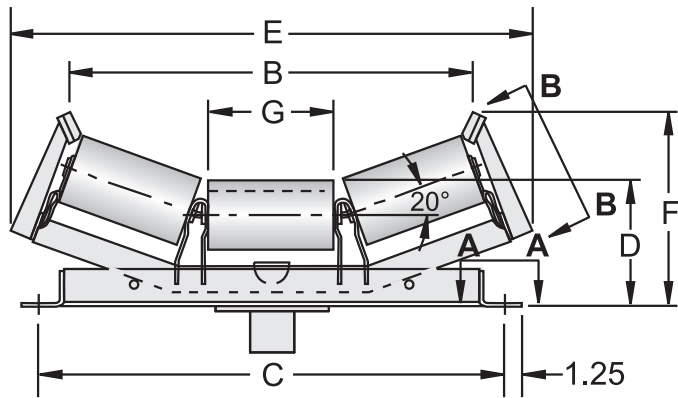

## CEMA C / D

Belt width, inches	Dia.	● Idler number	Standard Base (Belt width + 9")		Wide Base (Belt width + 15")		B	D	E	F	G	H	J	K
			Idler weight, pounds	C	Idler weight, pounds	C								
18	5"	C3508S-18	84	27.00	86	33.00	22.44	9.00	30.94	13.12	6.69	11.50	5.75	9.00
	6"	C3608S-18	91	27.00	93	33.00	22.12	9.50	30.56	13.56	6.69	11.50	5.75	9.00
20	5"	C3508S-20	89	29.00	91	35.00	24.62	9.00	33.06	13.38	7.44	11.50	5.75	9.00
	6"	C3608S-20	96	29.00	98	35.00	24.25	9.50	32.75	13.88	7.44	11.50	5.75	9.00
24	5"	3508S-24	100	33.00	102	39.00	28.56	9.00	37.00	13.88	8.81	11.50	5.75	9.00
	6"	3608S-24	108	33.00	110	39.00	28.19	9.50	36.69	14.31	8.81	11.50	5.75	9.00
30	5"	3508S-30	115	39.00	117	45.00	34.31	9.38	42.75	14.94	10.81	12.50	5.75	9.00
	6"	3608S-30	124	39.00	126	45.00	33.94	9.88	42.44	15.38	10.81	12.50	5.75	9.00
36	5"	3508S-36	131	45.00	133	51.00	40.06	9.38	48.56	15.62	12.81	12.50	5.75	9.00
	6"	3608S-36	142	45.00	144	51.00	39.75	9.88	48.00	16.06	12.81	12.50	5.75	9.00
42	5"	3508S-42	158	51.00	160	57.00	46.75	9.75	55.19	16.75	15.12	12.50	5.75	9.00
	6"	3608S-42	170	51.00	172	57.00	46.38	10.25	54.81	17.25	15.12	12.50	5.75	9.00
48	5"	3508S-48	167	57.00	169	63.00	52.50	9.75	60.94	17.44	17.12	12.50	5.75	9.00
	6"	3608S-48	180	57.00	182	63.00	52.12	10.25	60.62	17.94	17.12	12.50	5.75	9.00
54	5"	3508S-54	188	63.00	190	69.00	58.44	9.75	66.88	18.12	19.19	12.50	5.75	9.00
	6"	3608S-54	202	63.00	204	69.00	58.06	10.25	66.56	18.62	19.19	12.50	5.75	9.00
60	5"	3508S-60	206	69.00	208	75.00	64.19	9.75	72.62	18.81	21.19	12.50	5.75	9.00
	6"	3608S-60	222	69.00	224	75.00	63.81	10.25	72.31	19.31	21.19	12.50	5.75	9.00
72	5"	D3508S-72	242	81.00	245	87.00	75.69	10.00	84.19	20.44	25.19	15.50	8.50	13.00
	6"	D3608S-72	246	81.00	250	87.00	75.38	10.50	83.81	20.94	25.19	15.50	8.50	13.00

\*\* Elevation above adjacent idlers.

■ Bolt spacing recommended to permit adjustment is (J + 1.75").  
Example: If "J" = 5.75" then (5.75" + 1.75" = 7.5" bolt spacing).

● 1/4" thick rubber or urethane coated rolls, optional.

● CEMA C or D are available in belt widths of 24" - 60".

# 35°

## Troughed Belt Idlers, Equal Length Rolls

steel rolls

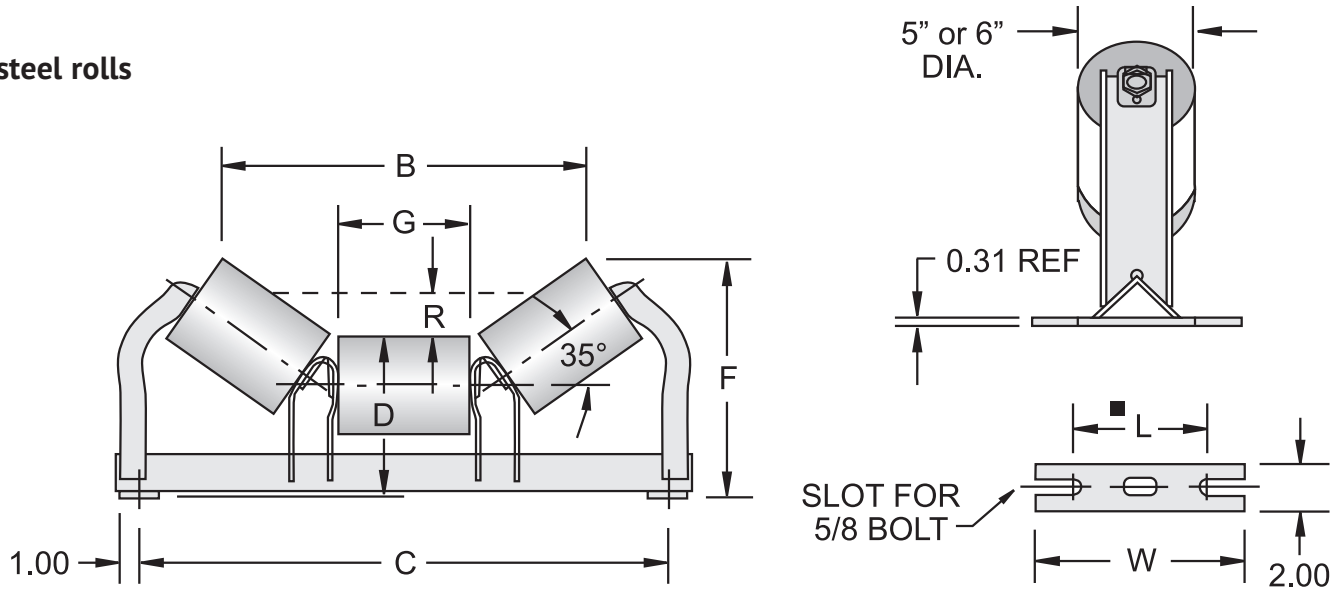

## CEMA C / D

Belt width, inches	Dia.	● Idler number	Standard Base (Belt width + 9")		Wide Base (Belt width + 15")		B	D	F	G	L	R**	W
			Idler weight, pounds	C	Idler weight, pounds	C							
18	5"	C3528S-18	45	27.00	47	33.00	18.62	8.25	12.25	6.69	5.75	1.56	9.00
	6"	C3628S-18	54	27.00	55	33.00	18.06	8.75	12.69	6.69	5.75	1.56	9.00
20	5"	C3528S-20	47	29.00	49	35.00	20.62	8.25	12.69	7.44	5.75	1.75	9.00
	6"	C3628S-20	59	29.00	61	35.00	20.06	8.75	13.06	7.44	5.75	1.75	9.00
24	5"	3528S-24	55	33.00	57	39.00	24.25	8.25	13.44	8.81	5.75	2.12	9.00
	6"	3628S-24	69	33.00	71	39.00	23.69	8.75	13.88	8.81	5.75	2.12	9.00
30	5"	3528S-30	63	39.00	65	45.00	29.50	8.62	15.00	10.81	5.75	2.69	9.00
	6"	3628S-30	73	39.00	75	45.00	28.94	9.12	15.38	10.81	5.75	2.69	9.00
36	5"	3528S-36	73	45.00	75	51.00	34.81	8.62	16.12	12.81	5.75	3.25	9.00
	6"	3628S-36	83	45.00	84	51.00	34.19	9.12	16.50	12.81	5.75	3.25	9.00
42	5"	3528S-42	92	51.00	95	57.00	40.88	9.00	17.81	15.12	5.75	3.81	9.00
	6"	3628S-42	102	51.00	105	57.00	40.31	9.50	18.25	15.12	5.75	3.81	9.00
48	5"	3528S-48	101	57.00	104	63.00	46.19	9.00	18.94	17.12	5.75	4.38	9.00
	6"	3628S-48	113	57.00	116	63.00	45.56	9.50	19.38	17.12	5.75	4.38	9.00
54	5"	3528S-54	109	63.00	112	69.00	51.62	9.00	20.12	19.19	5.75	4.94	9.00
	6"	3628S-54	121	63.00	124	69.00	51.06	9.50	20.56	19.19	5.75	4.94	9.00
60	5"	3528S-60	122	69.00	124	75.00	56.88	9.00	21.31	21.19	5.75	5.50	9.00
	6"	3628S-60	137	69.00	139	75.00	56.31	9.50	21.69	21.19	5.75	5.50	9.00
72	5"	D3528S-72	148	81.00	152	87.00	67.44	9.38	24.00	25.19	8.25	6.69	11.50
	6"	D3628S-72	163	81.00	167	87.00	66.88	9.88	24.38	25.19	8.25	6.69	11.50

\*\* To top of discharge or bend pulleys, except foot pulley.

■ Bolt spacing recommended to permit adjustment is  $(L + 1.75)$ .  
Example: If "L" = 5.75" then  $(5.75 + 1.75 = 7.5)$  bolt spacing).

● 1/4" thick rubber or urethane coated rolls, optional.

● CEMA C or D are available in belt widths of 24" - 60".

# 35°

## Troughed Belt Idlers, Equal Length Rolls

rubber cushion rolls (impact)

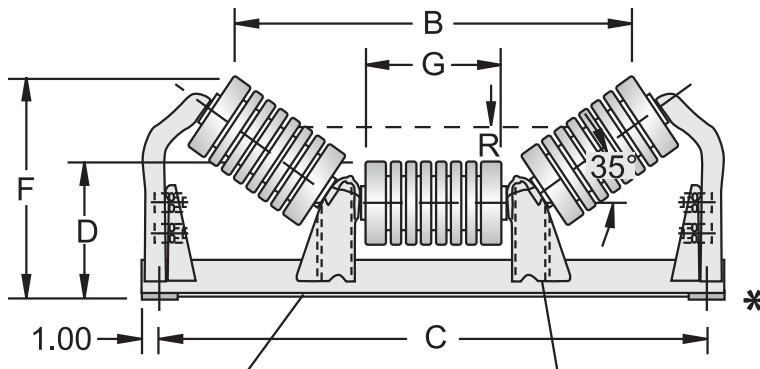

- 7 gage reinforcing plate for 36"-72" belt widths
- Heavy duty gussets for increased load capacity 36"-72" belt widths

\* Demountable end bracket supplied for 18"-72" belt widths

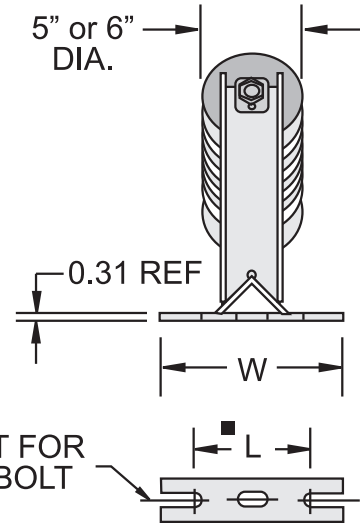

## CEMA C / D

Belt width, inches	Dia.	● Idler number	Standard Base (Belt width + 9")		Wide Base (Belt width + 15")		B	D	F	G	L	R**	W
			Idler weight, pounds	C	Idler weight, pounds	C							
Inches													
18	5"	C3530S-18	46	27.00	48	33.00	18.62	8.25	12.06	6.06	5.75	1.56	9.00
	6"	C3630S-18	53	27.00	55	33.00	17.62	8.75	12.50	6.06	5.75	1.56	9.00
20	5"	C3530S-20	52	29.00	53	35.00	20.19	8.25	12.50	6.81	5.75	1.75	9.00
	6"	C3630S-20	61	29.00	63	35.00	19.62	8.75	12.88	6.81	5.75	1.75	9.00
24	5"	3530S-24	57	33.00	59	39.00	23.81	8.25	13.25	8.19	5.75	2.12	9.00
	6"	3630S-24	66	33.00	67	39.00	23.25	8.75	13.69	8.19	5.75	2.12	9.00
30	5"	3530S-30	67	39.00	69	45.00	29.12	8.62	14.81	10.19	5.75	2.69	9.00
	6"	3630S-30	76	39.00	78	45.00	28.50	9.12	15.19	10.19	5.75	2.69	9.00
36	5"	3530S-36	77	45.00	79	51.00	34.38	8.62	15.94	12.19	5.75	3.31	9.00
	6"	3630S-36	89	45.00	91	51.00	33.75	9.12	16.44	12.19	5.75	3.31	9.00
42	5"	3530S-42	99	51.00	102	57.00	40.50	9.00	17.62	14.50	5.75	3.75	9.00
	6"	3630S-42	111	51.00	114	57.00	39.94	9.50	18.06	14.50	5.75	3.75	9.00
48	5"	3530S-48	109	57.00	112	63.00	45.75	9.00	18.81	16.50	5.75	4.38	9.00
	6"	3630S-48	124	57.00	127	63.00	45.25	9.50	19.19	16.50	5.75	4.38	9.00
54	5"	3530S-54	123	63.00	125	69.00	51.19	9.00	19.94	18.56	5.75	4.94	9.00
	6"	3630S-54	139	63.00	142	69.00	50.62	9.50	20.38	18.56	5.75	4.94	9.00
60	5"	3530S-60	134	69.00	136	75.00	56.50	9.00	21.12	20.56	5.75	5.50	9.00
	6"	3630S-60	152	69.00	155	75.00	56.94	9.50	21.50	20.56	5.75	5.50	9.00
72	5"	D3530S-72	157	81.00	162	87.00	67.00	9.38	23.62	24.56	8.25	6.62	11.50
	6"	D3630S-72	175	81.00	180	87.00	66.50	9.88	24.19	24.56	8.25	6.62	11.50

\*\* To top of discharge or bend pulleys, except foot pulley.

■ Bolt spacing recommended to permit adjustment is (L + 1.75"). Example: If "L" = 5.75" then (5.75" + 1.75" = 7.5" bolt spacing).

● CEMA C or D are available in belt widths of 24" - 60".



# 35°

## Troughed Belt Training Idlers, Equal Length Rolls

**positive action type**

(above deck mounting)

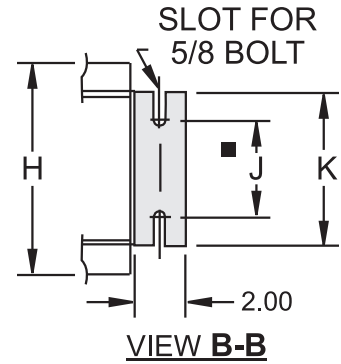
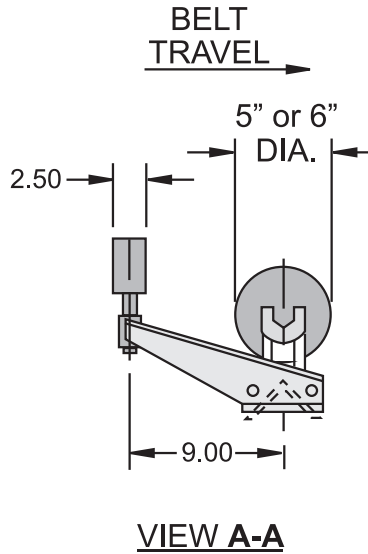
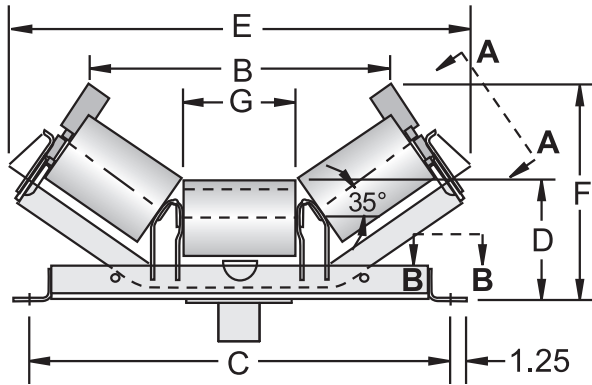

## CEMA C / D

Belt width, inches	Dia.	● Idler number	Standard Base (Belt width + 9")		Wide Base (Belt width + 15")		B	D	E	F	G	H	J	K
			Idler weight, pounds	C	Idler weight, pounds	C								
Inches														
18	5"	C3532S-18	96	27.00	98	33.00	19.04	9.00	30.62	16.08	6.69	11.50	5.75	9.00
	6"	C3632S-18	105	27.00	106	33.00	19.04	9.50	30.62	16.08	6.69	11.50	5.75	9.00
20	5"	C3532S-20	100	29.00	102	35.00	21.02	9.00	32.62	16.51	7.44	11.50	5.75	9.00
	6"	C3632S-20	112	29.00	114	35.00	21.02	9.50	32.62	16.51	7.44	11.50	5.75	9.00
24	5"	3532S-24	111	33.00	113	39.00	24.63	9.00	36.25	17.30	8.81	11.50	5.75	9.00
	6"	3632S-24	125	33.00	127	39.00	24.63	9.50	36.25	17.30	8.81	11.50	5.75	9.00
30	5"	3532S-30	127	39.00	129	45.00	29.91	9.38	41.50	18.82	10.81	12.50	5.75	9.00
	6"	3632S-30	139	39.00	141	45.00	29.91	9.88	41.50	18.82	10.81	12.50	5.75	9.00
36	5"	3532S-36	143	45.00	145	51.00	35.19	9.38	46.81	19.97	12.81	12.50	5.75	9.00
	6"	3632S-36	153	45.00	154	51.00	35.19	9.88	46.81	19.97	12.81	12.50	5.75	9.00
42	5"	3532S-42	170	51.00	172	57.00	41.28	9.75	52.88	21.67	15.12	12.50	5.75	9.00
	6"	3632S-42	180	51.00	182	57.00	41.28	10.25	52.88	21.67	15.12	12.50	5.75	9.00
48	5"	3532S-48	185	57.00	187	63.00	46.56	9.75	58.19	22.81	17.12	12.50	5.75	9.00
	6"	3632S-48	198	57.00	200	63.00	46.56	10.25	58.19	22.81	17.12	12.50	5.75	9.00
54	5"	3532S-54	200	63.00	202	69.00	52.02	9.75	63.62	24.00	19.19	12.50	5.75	9.00
	6"	3632S-54	212	63.00	214	69.00	52.02	10.25	63.62	24.00	19.19	12.50	5.75	9.00
60	5"	3532S-60	218	69.00	220	75.00	57.30	9.75	68.88	25.15	21.19	12.50	5.75	9.00
	6"	3632S-60	233	69.00	235	75.00	57.30	10.25	68.88	25.15	21.19	12.50	5.75	9.00
72	5"	D3532S-72	244	81.00	247	87.00	67.85	10.00	79.44	27.69	25.19	15.50	8.50	13.00
	6"	D3632S-72	253	81.00	256	87.00	67.85	10.50	79.44	27.69	25.19	15.50	8.50	13.00

\*\* Elevation above adjacent idlers.

■ Bolt spacing recommended to permit adjustment is (J + 1.75").  
Example: If "J" = 5.75" then (5.75" + 1.75" = 7.5" bolt spacing).

● 1/4" thick rubber or urethane coated rolls, optional.

● CEMA C or D are available in belt widths of 24" - 60".



# 35°

## Troughed Belt Training Idlers, Equal Length Rolls

### actuating shoe type reversing belts

(above deck mounting)

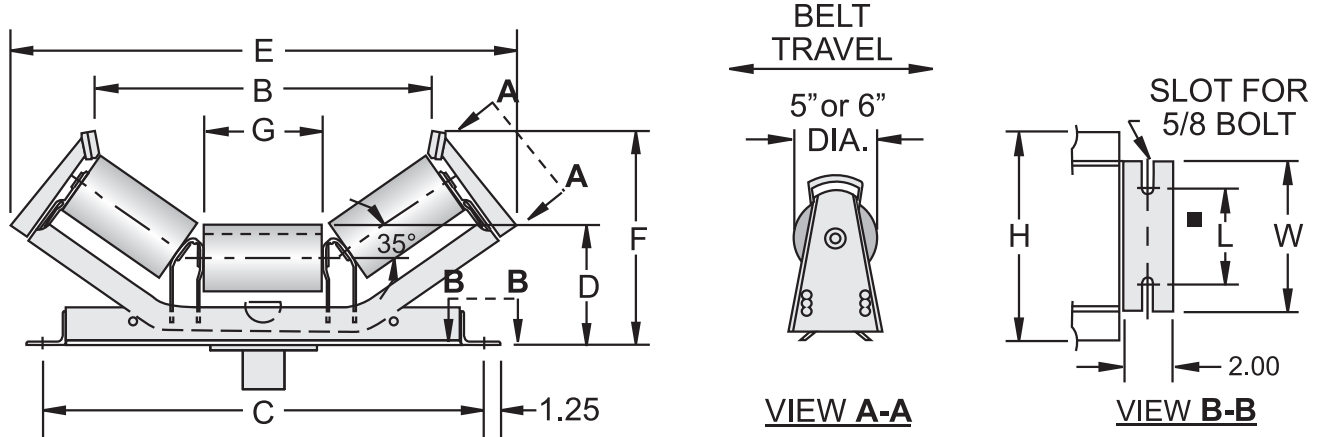

## CEMA C / D

Belt width, inches	Dia.	● Idler number	Standard Base (Belt width + 9")		Wide Base (Belt width + 15")		B	D	E	F	G	H	L	W
			Idler weight, pounds	C	Idler weight, pounds	C								
18	5"	C3537S-18	86	27.00	88	33.00	19.56	9.00	32.12	14.81	6.69	11.50	5.75	9.00
	6"	C3637S-18	95	27.00	96	33.00	18.94	9.50	31.56	15.25	6.69	11.50	5.75	9.00
20	5"	C3537S-20	90	29.00	92	35.00	21.50	9.00	34.12	15.25	7.44	11.50	5.75	9.00
	6"	C3637S-20	102	29.00	104	35.00	20.94	9.50	33.50	15.69	7.44	11.50	5.75	9.00
24	5"	3537S-24	101	33.00	103	39.00	25.19	9.00	37.75	16.06	8.81	11.50	5.75	9.00
	6"	3637S-24	115	33.00	117	39.00	24.56	9.50	37.19	16.44	8.81	11.50	5.75	9.00
30	5"	3537S-30	117	39.00	119	45.00	30.44	9.38	43.00	17.56	10.81	12.50	5.75	9.00
	6"	3637S-30	126	39.00	128	45.00	29.81	9.88	42.44	18.00	10.81	12.50	5.75	9.00
36	5"	3537S-36	133	45.00	135	51.00	35.69	9.38	48.25	18.69	12.81	12.50	5.75	9.00
	6"	3637S-36	143	45.00	144	51.00	35.12	9.88	47.69	19.12	12.81	12.50	5.75	9.00
42	5"	3537S-42	160	51.00	162	57.00	41.75	9.75	54.38	20.38	15.12	12.50	5.75	9.00
	6"	3637S-42	170	51.00	172	57.00	41.19	10.25	53.75	20.81	15.12	12.50	5.75	9.00
48	5"	3537S-48	175	57.00	177	63.00	47.06	9.75	59.62	21.56	17.12	12.50	5.75	9.00
	6"	3637S-48	188	57.00	190	63.00	46.50	10.25	59.06	21.94	17.12	12.50	5.75	9.00
54	5"	3537S-54	190	63.00	192	69.00	52.50	9.75	65.12	22.75	19.19	12.50	5.75	9.00
	6"	3637S-54	202	63.00	204	69.00	51.94	10.25	64.50	23.12	19.19	12.50	5.75	9.00
60	5"	3537S-60	208	69.00	210	75.00	57.81	9.75	70.38	23.88	21.19	12.50	5.75	9.00
	6"	3637S-60	223	69.00	225	75.00	57.19	10.25	69.81	24.31	21.19	12.50	5.75	9.00
72	5"	D3537S-72	234	81.00	237	87.00	68.38	10.00	80.94	26.44	25.19	15.50	8.50	13.00
	6"	D3637S-72	248	81.00	252	87.00	67.75	10.50	80.38	26.81	25.19	15.50	8.50	13.00

\*\* Elevation above adjacent idlers.

■ Bolt spacing recommended to permit adjustment is (L + 1.75").  
Example: If "L" = 5.75" then (5.75" + 1.75" = 7.5" bolt spacing).

● 1/4" thick rubber or urethane coated rolls, optional.

● CEMA C or D are available in belt widths of 24" - 60".

# 45° Troughed Belt Idlers, Equal Length Rolls

steel rolls

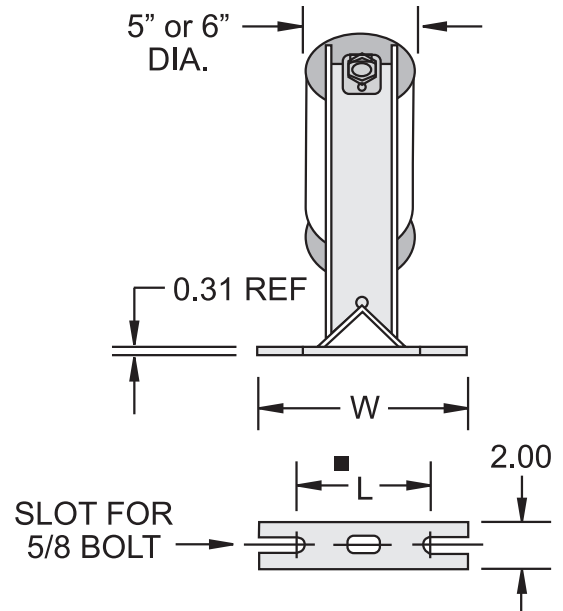
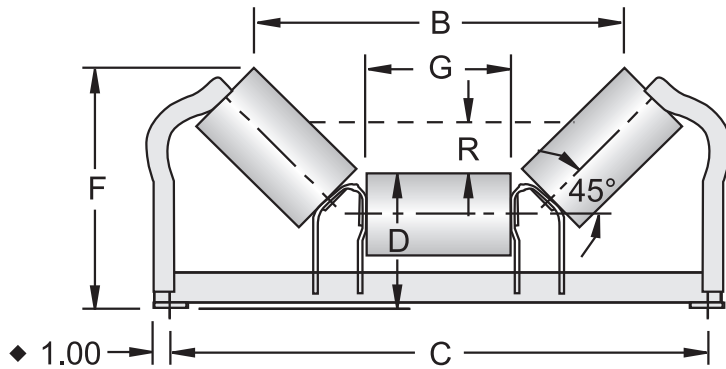

## CEMA C / D

Belt width, inches	Dia.	● Idler number	Standard Base (Belt width + 9")		Wide Base (Belt width + 15")		B	D	F	G	L	R**	W
			Idler weight, pounds	C	Idler weight, pounds	C							
20	5"	C3502S-20	49	29.00	51	35.00	19.31	8.25	13.81	7.44	5.75	2.12	9.00
	6"	C3602S-20	61	29.00	63	35.00	18.62	8.75	14.19	7.44	5.75	2.12	9.00
24	5"	3502S-24	56	33.00	58	39.00	22.69	8.25	14.75	8.81	5.75	2.56	9.00
	6"	3602S-24	70	33.00	72	39.00	21.94	8.75	15.12	8.81	5.75	2.56	9.00
30	5"	3502S-30	65	39.00	67	45.00	27.50	8.62	16.56	10.81	5.75	3.31	9.00
	6"	3602S-30	75	39.00	77	45.00	26.75	9.12	16.88	10.81	5.75	3.31	9.00
36	5"	3502S-36	75	45.00	77	51.00	32.31	8.62	18.00	12.81	5.75	4.00	9.00
	6"	3602S-36	85	45.00	87	51.00	31.62	9.12	18.31	12.81	5.75	4.00	9.00
42	5"	3502S-42	95	51.00	98	57.00	37.88	9.00	20.00	15.12	5.75	4.62	9.00
	6"	3602S-42	104	51.00	107	57.00	37.19	9.50	20.31	15.12	5.75	4.62	9.00
48	5"	3502S-48	103	57.00	106	63.00	42.75	9.00	21.38	17.12	5.75	5.38	9.00
	6"	3602S-48	116	57.00	119	63.00	42.00	9.50	21.75	17.12	5.75	5.38	9.00
54	5"	3502S-54	112	63.00	115	69.00	47.69	9.00	22.88	19.19	5.75	6.06	9.00
	6"	3602S-54	123	63.00	126	69.00	47.00	9.50	23.19	19.19	5.75	6.06	9.00
60	5"	3502S-60	125	69.00	128	75.00	52.56	9.00	24.25	21.19	5.75	6.75	9.00
	6"	3602S-60	140	69.00	143	75.00	51.81	9.50	24.62	21.19	5.75	6.75	9.00
72	5"	D3502S-72	150	81.00	154	87.00	62.19	9.38	27.50	25.19	8.25	8.19	11.50
	6"	D3602S-72	166	81.00	170	87.00	61.50	9.88	27.88	25.19	8.25	8.19	11.50

\*\* To top of discharge or bend pulleys, except foot pulley.

■ Bolt spacing recommended to permit adjustment is (L + 1.75"). Example: If "L" = 5.75" then (5.75" + 1.75" = 7.5" bolt spacing).

● 1/4" thick rubber or urethane coated rolls, optional.

● CEMA C or D are available in belt widths of 24" - 60".

# 45° Troughed Belt Idlers, Equal Length Rolls

rubber cushion rolls (impact)

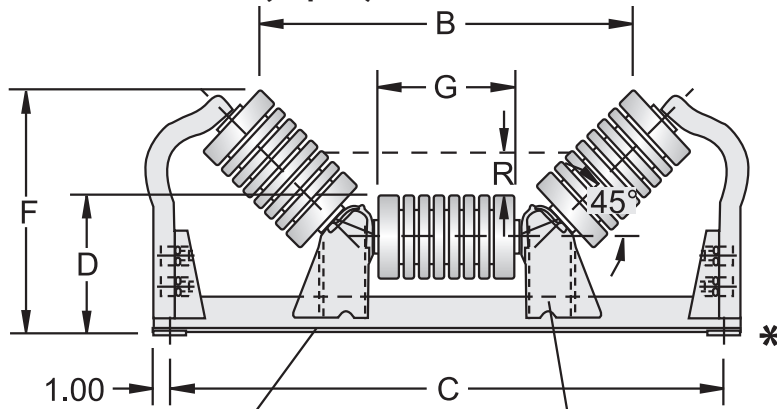

- 7 gage reinforcing plate for 36"-72" belt widths
- Heavy duty gussets for increased load capacity 36"-72" belt widths

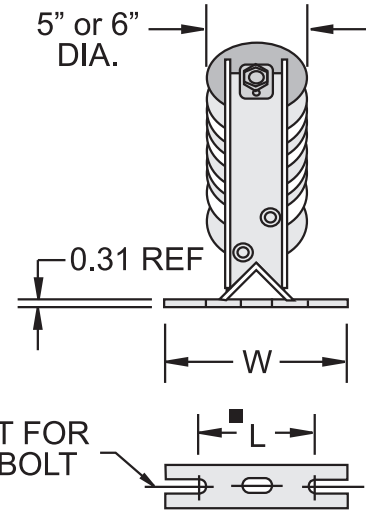

\* Demountable end bracket supplied for 20"- 72" belt widths

## CEMA C / D

Belt width, inches	Dia.	● Idler number	Standard Base (Belt width + 9")		Wide Base (Belt width + 15")		B	D	F	G	L	R**	W
			Idler weight, pounds	C	Idler weight, pounds	C							
20	5"	C3523S-20	53	29.00	54	35.00	18.88	8.25	13.62	6.81	5.75	2.12	9.00
	6"	C3623S-20	62	29.00	64	35.00	18.19	8.75	13.94	6.81	5.75	2.12	9.00
24	5"	3523S-24	59	33.00	61	39.00	22.19	8.25	14.56	8.19	5.75	2.62	9.00
	6"	3623S-24	67	33.00	68	39.00	21.50	8.75	14.94	8.19	5.75	2.62	9.00
30	5"	3523S-30	69	39.00	71	45.00	27.06	8.62	16.31	10.19	5.75	3.31	9.00
	6"	3623S-30	74	39.00	76	45.00	26.31	9.12	16.69	10.19	5.75	3.31	9.00
36	5"	3523S-36	80	45.00	82	51.00	31.88	8.62	17.75	12.19	5.75	4.00	9.00
	6"	3623S-36	80	45.00	82	51.00	31.19	9.12	18.12	12.19	5.75	4.00	9.00
42	5"	3523S-42	101	51.00	104	57.00	37.44	9.00	19.75	14.50	5.75	4.62	9.00
	6"	3623S-42	113	51.00	116	57.00	36.75	9.50	20.12	14.50	5.75	4.62	9.00
48	5"	3523S-48	112	57.00	115	63.00	42.25	9.00	21.19	16.50	5.75	5.38	9.00
	6"	3623S-48	127	57.00	130	63.00	41.56	9.50	21.56	16.50	5.75	5.38	9.00
54	5"	3523S-54	125	63.00	127	69.00	47.25	9.00	22.62	18.56	5.75	6.06	9.00
	6"	3623S-54	141	63.00	144	69.00	46.56	9.50	23.00	18.56	5.75	6.06	9.00
60	5"	3523S-60	136	69.00	138	75.00	52.06	9.00	24.06	20.56	5.75	6.75	9.00
	6"	3623S-60	155	69.00	158	75.00	51.38	9.50	24.38	20.56	5.75	6.75	9.00
72	5"	D3523S-72	159	81.00	164	87.00	61.75	9.38	27.25	24.56	8.25	8.19	11.50
	6"	D3623S-72	178	81.00	183	87.00	61.06	9.88	27.62	24.56	8.25	8.19	11.50

\*\* To top of discharge or bend pulleys, except foot pulley.

■ Bolt spacing recommended to permit adjustment is (L + 1.75"). Example: If "L" = 5.75" then (5.75" + 1.75" = 7.5" bolt spacing).

● CEMA C or D are available in belt widths of 24" - 60".

# 45° Troughed Belt Training Idlers, Equal Length Rolls

**positive action type**  
(above deck mounting)

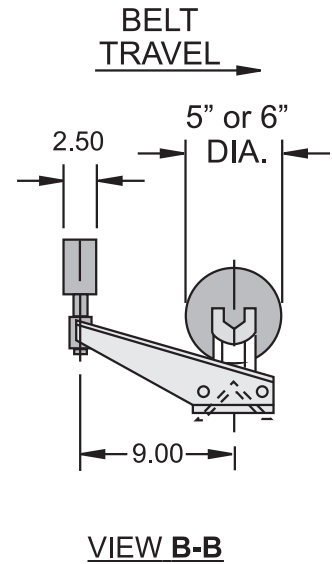
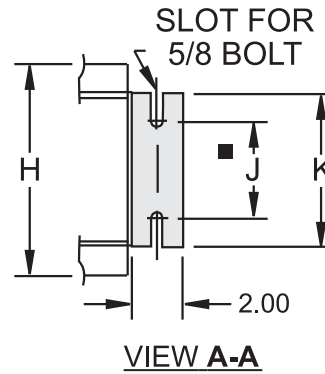
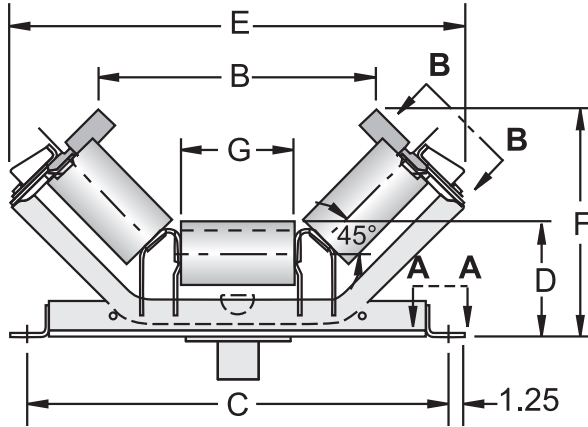

## CEMA C / D

Belt width, inches	Dia.	● Idler number	Standard Base (Belt width + 9")		Wide Base (Belt width + 15")		B	D	E	F	G	H	J	K
			Idler weight, pounds	C	Idler weight, pounds	C								
Inches														
18	5"	C3509S-18	96	27.00	98	33.00	16.96	9.00	30.56	17.04	6.69	11.50	5.75	9.00
	6"	C3609S-18	105	27.00	107	33.00	16.96	9.50	30.56	17.04	6.69	11.50	5.75	9.00
20	5"	C3509S-20	101	29.00	103	35.00	18.77	9.00	32.38	17.57	7.44	11.50	5.75	9.00
	6"	C3609S-20	113	29.00	115	35.00	18.77	9.50	32.38	17.57	7.44	11.50	5.75	9.00
24	5"	3509S-24	112	33.00	114	39.00	22.08	9.00	35.69	18.54	8.81	11.50	5.75	9.00
	6"	3609S-24	126	33.00	128	39.00	22.08	9.50	35.69	18.54	8.81	11.50	5.75	9.00
30	5"	3509S-30	128	39.00	130	45.00	26.91	9.38	40.50	20.33	10.81	12.50	5.75	9.00
	6"	3609S-30	139	39.00	141	45.00	26.91	9.88	40.50	20.33	10.81	12.50	5.75	9.00
36	5"	3509S-36	145	45.00	147	51.00	31.73	9.38	45.31	21.75	12.81	12.50	5.75	9.00
	6"	3609S-36	155	45.00	157	51.00	31.73	9.88	45.31	21.75	12.81	12.50	5.75	9.00
42	5"	3509S-42	173	51.00	175	57.00	37.31	9.75	50.94	23.75	15.12	12.50	5.75	9.00
	6"	3609S-42	183	51.00	185	57.00	37.31	10.25	50.94	23.75	15.12	12.50	5.75	9.00
48	5"	3509S-48	188	57.00	190	63.00	42.14	9.75	55.75	25.17	17.12	12.50	5.75	9.00
	6"	3609S-48	200	57.00	202	63.00	42.14	10.25	55.75	25.17	17.12	12.50	5.75	9.00
54	5"	3509S-54	203	63.00	205	69.00	47.14	9.75	60.75	26.63	19.19	12.50	5.75	9.00
	6"	3609S-54	209	63.00	211	69.00	47.14	10.25	60.75	26.63	19.19	12.50	5.75	9.00
60	5"	3509S-60	219	69.00	221	75.00	51.97	9.75	65.56	28.04	21.19	12.50	5.75	9.00
	6"	3609S-60	234	69.00	236	75.00	51.97	10.25	65.56	28.04	21.19	12.50	5.75	9.00
72	5"	D3509S-72	244	81.00	247	87.00	61.62	10.00	75.19	31.12	25.19	15.50	8.50	13.00
	6"	D3609S-72	259	81.00	263	87.00	61.62	10.50	75.19	31.12	25.19	15.50	8.50	13.00

\*\* Elevation above adjacent idlers.

■ Bolt spacing recommended to permit adjustment is (J + 1.75").  
Example: If "J" = 5.75" then (5.75" + 1.75" = 7.5" bolt spacing).

- 1/4" thick rubber or urethane coated rolls, optional.
- CEMA C or D are available in belt widths of 24" - 60".

# 45° Troughed Belt Training Idlers, Equal Length Rolls

## actuating shoe type reversing belts

(above deck mounting)

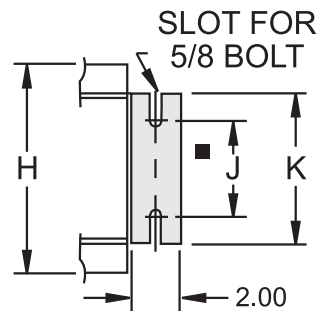
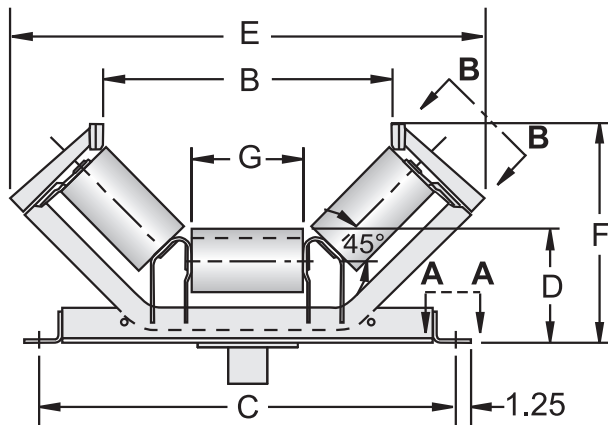

VIEW A-A

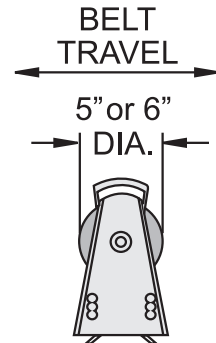

VIEW B-B

## CEMA C / D

Belt width, inches	Dia.	● Idler number	Standard Base (Belt width + 9")		Wide Base (Belt width + 15")		B	D	E	F	G	H	J	K
			Idler weight, pounds	C	Idler weight, pounds	C								
18	5"	C3511S-18	83	27.00	85	33.00	17.75	9.00	32.62	15.88	6.69	11.50	5.75	9.00
	6"	C3611S-18	95	27.00	97	33.00	17.06	9.50	31.88	16.25	6.69	11.50	5.75	9.00
20	5"	C3511S-20	88	29.00	90	35.00	19.56	9.00	34.44	16.44	7.44	11.50	5.75	9.00
	6"	C3611S-20	103	29.00	105	35.00	18.88	9.50	33.69	16.75	7.44	11.50	5.75	9.00
24	5"	3511S-24	99	33.00	101	39.00	22.88	9.00	37.75	17.38	8.81	11.50	5.75	9.00
	6"	3611S-24	116	33.00	118	39.00	22.19	9.50	37.00	17.75	8.81	11.50	5.75	9.00
30	5"	3511S-30	109	39.00	111	45.00	27.81	9.38	42.56	19.19	10.81	12.50	5.75	9.00
	6"	3611S-30	129	39.00	131	45.00	27.00	9.88	41.88	19.50	10.81	12.50	5.75	9.00
36	5"	3511S-36	123	45.00	125	51.00	32.50	9.38	47.38	20.56	12.81	12.50	5.75	9.00
	6"	3611S-36	145	45.00	147	51.00	31.81	9.88	46.69	20.94	12.81	12.50	5.75	9.00
42	5"	3511S-42	148	51.00	150	57.00	38.12	9.75	52.94	22.56	15.12	12.50	5.75	9.00
	6"	3611S-42	173	51.00	175	57.00	37.38	10.25	52.25	22.94	15.12	12.50	5.75	9.00
48	5"	3511S-48	163	57.00	165	63.00	42.94	9.75	57.94	24.00	17.12	12.50	5.75	9.00
	6"	3611S-48	190	57.00	192	63.00	42.25	10.25	57.06	24.38	17.12	12.50	5.75	9.00
54	5"	3511S-54	175	63.00	178	69.00	47.94	9.75	62.75	25.44	19.19	12.50	5.75	9.00
	6"	3611S-54	204	63.00	206	69.00	47.19	10.25	62.06	25.81	19.19	12.50	5.75	9.00
60	5"	3511S-60	191	69.00	193	75.00	52.75	9.75	67.62	26.88	21.19	12.50	5.75	9.00
	6"	3611S-60	224	69.00	226	75.00	52.00	10.25	66.88	27.25	21.19	12.50	5.75	9.00
72	5"	D3511S-72	235	81.00	238	87.00	62.38	10.00	77.25	29.94	25.19	15.50	8.50	13.00
	6"	D3611S-72	249	81.00	253	87.00	61.69	10.50	76.56	30.31	25.19	15.50	8.50	13.00

\*\* Elevation above adjacent idlers.

■ Bolt spacing recommended to permit adjustment is (J + 1.75").  
Example: If "J" = 5.75" then (5.75" + 1.75" = 7.5" bolt spacing).

● 1/4" thick rubber or urethane coated rolls, optional.

● CEMA C or D are available in belt widths of 24" - 60".

# 20° Troughed Belt Picking & Feeding Conveyor Idlers

steel rolls

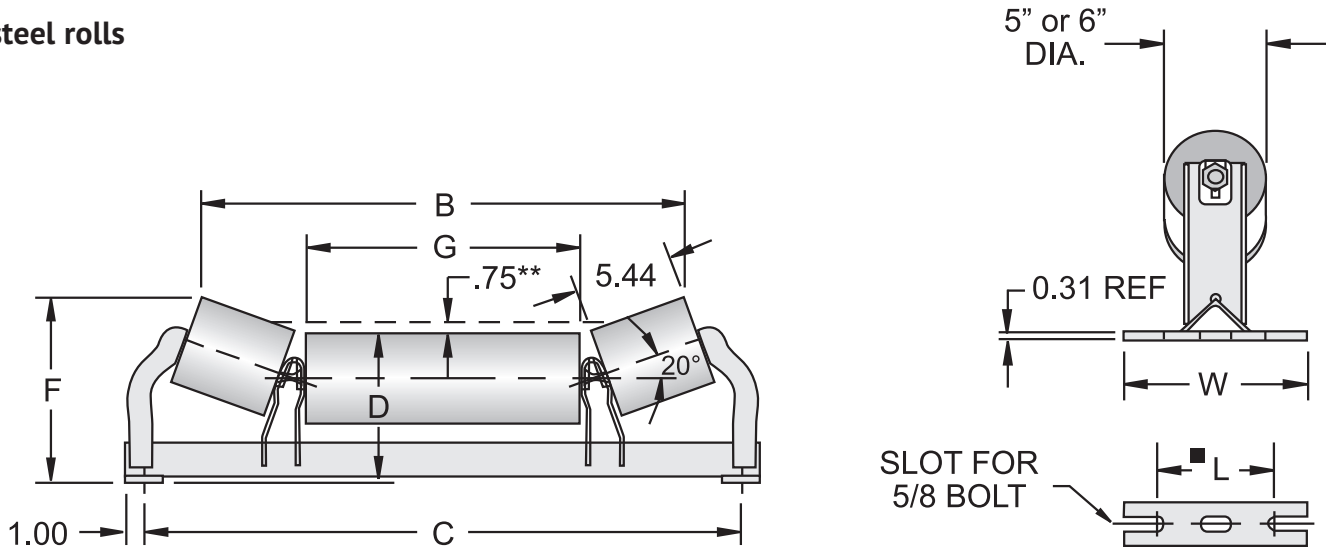

## CEMA C / D

Belt width, inches	Dia.	● Idler number	Standard Base (Belt width + 9")		Wide Base (Belt width + 15")		B	D	F	G	L	W
			Idler weight, pounds	C	Idler weight, pounds	C						
24	5"	C3505S-24	54	33.00	58	39.00	26.69	8.25	10.25	15.12	5.75	9.00
	6"	C3605S-24	64	33.00	67	39.00	26.31	8.75	10.75	15.12	5.75	9.00
30	5"	3505S-30	59	39.00	61	45.00	32.19	8.62	10.62	20.62	5.75	9.00
	6"	3605S-30	74	39.00	76	45.00	31.81	9.12	11.12	20.62	5.75	9.00
36	5"	3505S-36	69	45.00	71	51.00	38.19	8.62	10.62	26.62	5.75	9.00
	6"	3605S-36	79	45.00	81	51.00	37.81	9.12	11.12	26.62	5.75	9.00
42	5"	3505S-42	84	51.00	87	57.00	44.19	9.00	11.00	32.62	5.75	9.00
	6"	3605S-42	98	51.00	101	57.00	43.81	9.50	11.44	32.62	5.75	9.00
48	5"	3505S-48	93	57.00	96	63.00	50.19	9.00	11.00	38.62	5.75	9.00
	6"	3605S-48	106	57.00	109	63.00	49.81	9.50	11.44	38.62	5.75	9.00
54	5"	3505S-54	100	63.00	103	69.00	56.19	9.00	11.00	44.62	5.75	9.00
	6"	3605S-54	114	63.00	117	69.00	55.81	9.50	11.44	44.62	5.75	9.00
60	5"	3505S-60	110	69.00	112	75.00	62.19	9.00	11.00	50.62	5.75	9.00
	6"	3605S-60	128	69.00	131	75.00	61.81	9.50	11.44	50.62	5.75	9.00
72	5"	D3505S-72	164	81.00	180	87.00	74.19	9.38	11.38	62.62	8.25	11.50
	6"	D3605S-72	184	81.00	200	87.00	73.81	9.88	11.81	62.62	8.25	11.50

\*\* To top of discharge or bend pulleys, except foot pulley.

■ Bolt spacing recommended to permit adjustment is (L + 1.75"). Example: If "L" = 5.75" then (5.75" + 1.75" = 7.5" bolt spacing).

● 1/4" thick rubber or urethane coated rolls, optional.

● CEMA C or D are available in belt widths of 24" - 60".



# 20°

## Troughed Belt Picking & Feeding Conveyor Idlers

steel end rolls with rubber cushion center roll

(impact type)

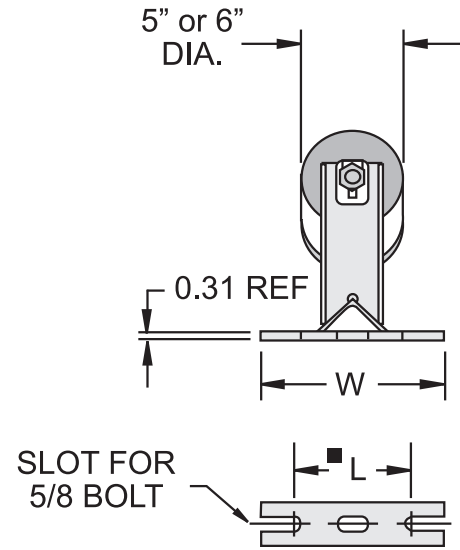
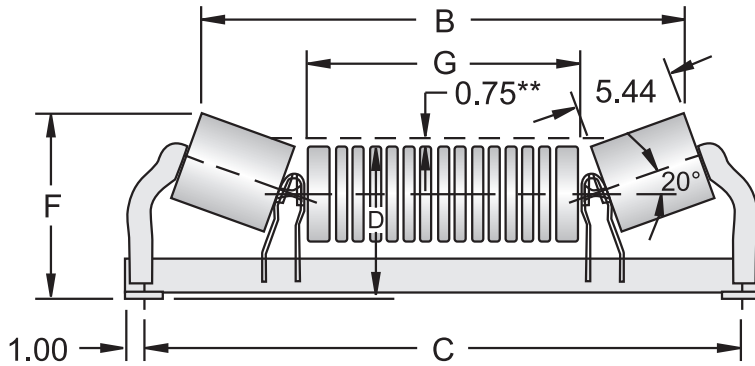

## CEMA C / D

Belt width, inches	Dia.	○ ● Idler number	Standard Base (Belt width + 9")		Wide Base (Belt width + 15")		B	D	F	G	L	W
			Idler weight, pounds	C	Idler weight, pounds	C						
24	5"	C3505RCS-24	57	33.00	61	39.00	26.69	8.25	10.25	14.50	5.75	9.00
	6"	C3605RCS-24	63	33.00	66	39.00	26.31	8.75	10.75	14.50	5.75	9.00
30	5"	3505RCS-30	70	39.00	72	45.00	32.19	8.62	10.62	20.25	5.75	9.00
	6"	3605RCS-30	77	39.00	78	45.00	31.81	9.12	11.12	20.25	5.75	9.00
36	5"	3505RCS-36	74	45.00	76	51.00	38.19	8.62	10.62	26.25	5.75	9.00
	6"	3605RCS-36	86	45.00	88	51.00	37.81	9.12	11.12	26.25	5.75	9.00
42	5"	3505RCS-42	92	51.00	95	57.00	44.19	9.00	11.00	32.25	5.75	9.00
	6"	3605RCS-42	105	51.00	108	57.00	43.81	9.50	11.44	32.25	5.75	9.00
48	5"	3505RCS-48	101	57.00	104	63.00	50.19	9.00	11.00	38.25	5.75	9.00
	6"	3605RCS-48	116	57.00	119	63.00	49.81	9.50	11.44	38.25	5.75	9.00
54	5"	3505RCS-54	111	63.00	114	69.00	56.19	9.00	11.00	44.25	5.75	9.00
	6"	3605RCS-54	130	63.00	133	69.00	55.81	9.50	11.44	44.25	5.75	9.00
60	5"	3505RCS-60	122	69.00	125	75.00	62.19	9.00	11.00	50.25	5.75	9.00
	6"	3605RCS-60	137	69.00	140	75.00	61.81	9.50	11.44	50.25	5.75	9.00
72	5"	D3505RCS-72	164	81.00	180	87.00	74.19	9.38	11.38	62.25	8.25	11.50
	6"	D3605RCS-72	183	81.00	199	87.00	73.81	9.88	11.81	62.25	8.25	11.50

\*\* To top of discharge or bend pulleys, except foot pulley.

■ Bolt spacing recommended to permit adjustment is (L + 1.75"). Example: If "L" = 5.75" then (5.75" + 1.75" = 7.5" bolt spacing).

○ Available with rubber cushion end rolls; specify suffix RS. Example 3505RS-24.

● CEMA C or D are available in belt widths of 30" - 60".

# Variable Troughed Belt Idlers

## 10° - 35° Adjustment

**positive action type**  
(above deck mounting)

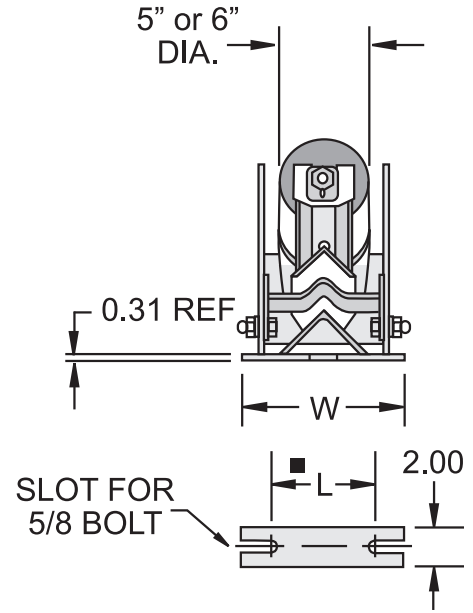
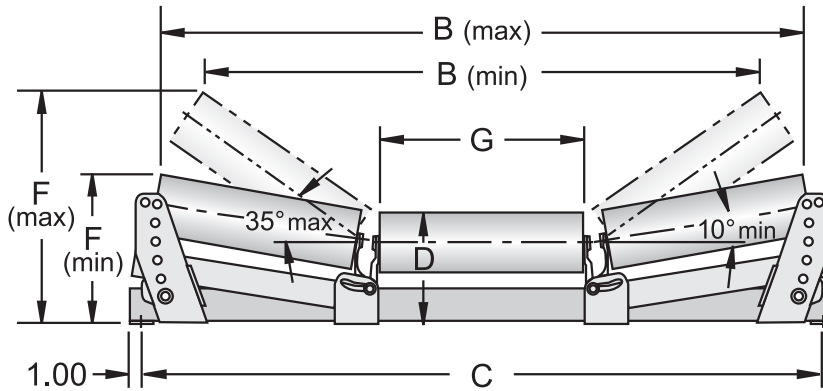

## CEMA C / D

Belt width, inches	Dia.	● Idler number	Standard Base (Belt width + 9")		Wide Base (Belt width + 15")		B		□	F		G	L	W
			Idler weight, pounds	C	Idler weight, pounds	C	MIN.	MAX.		D	MIN.			
									Inches					
24	5"	3506S-24	97	33.00	100	39.00	24.62	29.12	9.31	11.12	14.75	8.81	5.75	9.00
	6"	3606S-24	110	33.00	113	39.00	24.00	28.94	9.81	11.62	15.12	8.81	5.75	9.00
30	5"	3506S-30	107	39.00	110	45.00	29.88	35.06	9.31	11.44	15.88	10.81	5.75	9.00
	6"	3606S-30	117	39.00	120	45.00	29.31	34.88	9.81	11.94	16.31	10.81	5.75	9.00
36	5"	3506S-36	122	45.00	125	51.00	35.12	41.00	9.31	11.81	17.00	12.81	5.75	9.00
	6"	3606S-36	132	45.00	134	51.00	34.56	40.81	9.81	12.31	17.44	12.81	5.75	9.00
42	5"	3506S-42	134	51.00	137	57.00	41.25	47.88	9.31	12.19	18.38	15.12	5.75	9.00
	6"	3606S-42	143	51.00	146	57.00	40.69	47.69	9.81	12.69	18.75	15.12	5.75	9.00
48	5"	3506S-48	149	57.00	152	63.00	46.56	53.81	9.31	12.50	19.50	17.12	5.75	9.00
	6"	3606S-48	161	57.00	164	63.00	46.00	53.62	9.81	13.00	19.88	17.12	5.75	9.00
54	5"	3506S-54	159	63.00	162	69.00	52.00	59.94	9.31	12.88	20.69	19.19	5.75	9.00
	6"	3606S-54	171	63.00	174	69.00	51.44	59.81	9.81	13.38	21.06	19.19	5.75	9.00
60	5"	3506S-60	171	69.00	173	75.00	57.31	65.88	9.31	13.25	21.81	21.19	5.75	9.00
	6"	3606S-60	186	69.00	188	75.00	56.75	65.75	9.81	13.69	22.25	21.19	5.75	9.00
72	5"	D3506S-72	197	81.00	201	87.00	68.19	77.75	9.69	13.88	24.12	25.19	8.25	11.50
	6"	D3606S-72	211	81.00	215	87.00	67.62	77.62	10.19	14.38	24.56	25.19	8.25	11.50

- Bolt spacing recommended to permit adjustment is (L + 1.75"). Example: If "L" = 5.75" then (5.75" + 1.75" = 7.5" bolt spacing).
- Shim as required to contact belt and support load.
- 1/4" thick rubber or urethane coated rolls, optional.
- CEMA C or D are available in belt widths of 24" - 60".



# Flat Belt Idlers

steel rolls

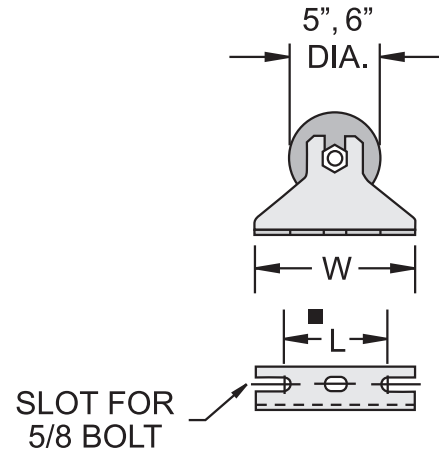
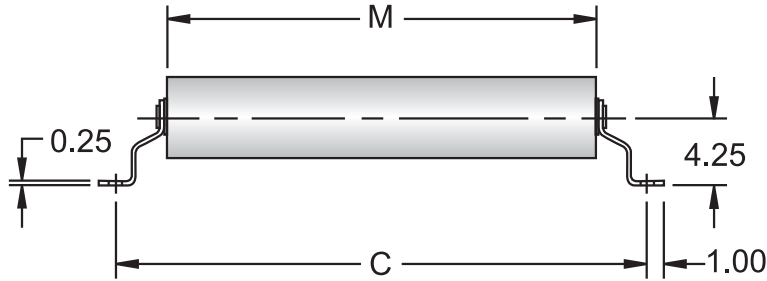

## CEMA C / D

Belt width, inches	Dia.	● * Idler number	Standard Base (Belt width + 9")			Wide Base (Belt width + 15")			L	W
			Idler weight, pounds	C	M	Idler weight, pounds	C	M		
				Inches			Inches			
18	5"	C3513S-18	30	27.00	20.62	38	33.00	26.62	5.75	8.88
	6"	C3613S-18	35	27.00	20.62	46	33.00	26.62	5.75	8.88
20	5"	C3513S-20	32	29.00	22.62	40	35.00	28.62	5.75	8.88
	6"	C3613S-20	38	29.00	22.62	49	35.00	28.62	5.75	8.88
24	5"	3513S-24	36	33.00	26.62	44	39.00	32.62	5.75	8.88
	6"	3613S-24	42	33.00	26.62	53	39.00	32.62	5.75	8.88
30	5"	3513S-30	42	39.00	32.62	50	45.00	38.62	5.75	8.88
	6"	3613S-30	50	39.00	32.62	61	45.00	38.62	5.75	8.88
36	5"	3513S-36	48	45.00	38.62	56	51.00	44.62	5.75	8.88
	6"	3613S-36	58	45.00	38.62	69	51.00	44.62	5.75	8.88
42	5"	3513S-42	53	51.00	44.62	61	57.00	50.62	5.75	8.88
	6"	3613S-42	63	51.00	44.62	74	57.00	50.62	5.75	8.88
48	5"	3513S-48	60	57.00	50.62	<i>Reference D3513S-48</i>			5.75	8.88
	6"	3613S-48	72	57.00	50.62				5.75	8.88
48	5"	D3513S-48	62	57.00	50.62	88	63.00	56.62	5.75	8.88
	6"	D3613S-48	74	57.00	50.62	102	63.00	56.62	5.75	8.88
54	5"	D3513S-54	88	63.00	56.62	98	69.00	62.62	5.75	8.88
	6"	D3613S-54	102	63.00	56.62	113	69.00	62.62	5.75	8.88
60	5"	D3513S-60	98	69.00	62.62	108	75.00	68.62	5.75	8.88
	6"	D3613S-60	113	69.00	62.62	123	75.00	68.62	5.75	8.88
66	5"	D3513S-66	110	75.00	68.62	122	81.00	74.62	5.75	8.88
	6"	D3613S-66	125	75.00	68.62	135	81.00	74.62	5.75	8.88
72	5"	D3513S-72	122	81.00	74.62	133	87.00	80.62	5.75	8.88
	6"	D3613S-72	135	81.00	74.62	147	87.00	80.62	5.75	8.88
78	5"	D3513S-78	135	87.00	80.62	N/A	N/A	N/A	5.75	8.88
	6"	D3613S-78	148	87.00	80.62	N/A	N/A	N/A	5.75	8.88

■ Bolt spacing recommended to permit adjustment is (L + 1.75").  
Example: If "L" = 5.75" then (5.75" + 1.75" = 7.5" bolt spacing).

\* For belt widths + 15" mounting above 42"  
use CEMA D and next higher belt width.

● 1/4" thick rubber or urethane coated rolls, optional.  
● CEMA C or D are available in belt widths of 24" - 48".

# Flat Belt Idlers

steel rolls, live shaft type

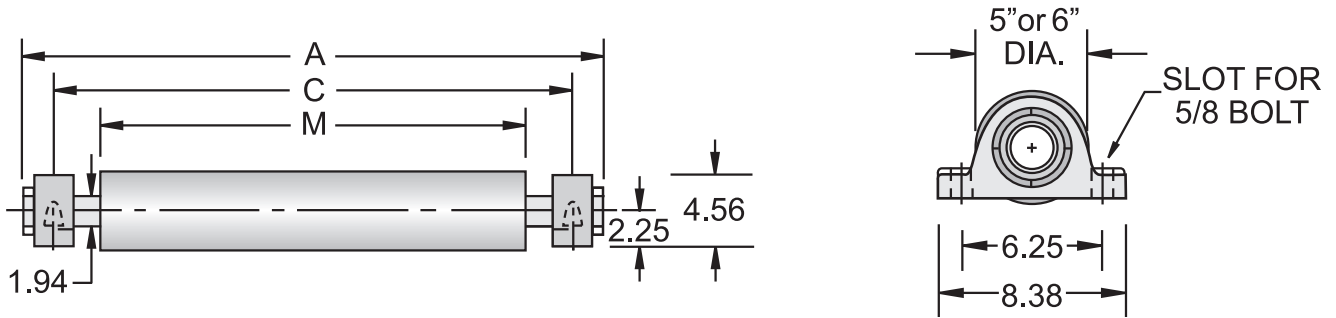

## CEMA C / D

Belt width, inches	Dia.	Idler number	Standard Base (Belt width + 9")			Wide Base (Belt width + 15")				
			Idler weight, pounds*	A	C	M	Idler weight, pounds*	A	C	M
				Inches				Inches		
18	5"	C3513L-18	80	31.00	27.00	21.00	91	37.00	33.00	27.00
	6"	C3613L-18	89	31.00	27.00	21.00	102	37.00	33.00	27.00
20	5"	C3513L-20	84	33.00	29.00	23.00	95	39.00	35.00	29.00
	6"	C3613L-20	93	33.00	29.00	23.00	106	39.00	35.00	29.00
24	5"	C3513L-24	91	37.00	33.00	27.00	102	43.00	39.00	33.00
	6"	C3613L-24	102	37.00	33.00	27.00	114	43.00	39.00	33.00
30	5"	C3513L-30	102	43.00	39.00	33.00	114	49.00	45.00	39.00
	6"	C3613L-30	114	43.00	39.00	33.00	127	49.00	45.00	39.00
36	5"	C3513L-36	114	49.00	45.00	39.00	125	55.00	51.00	45.00
	6"	C3613L-36	127	49.00	45.00	39.00	140	55.00	51.00	45.00
42	5"	C3513L-42	125	55.00	51.00	45.00	137	61.00	57.00	51.00
	6"	C3613L-42	140	55.00	51.00	45.00	152	61.00	57.00	51.00
48	5"	C3513L-48	137	61.00	57.00	51.00	148	67.00	63.00	57.00
	6"	C3613L-48	152	61.00	57.00	51.00	165	67.00	63.00	57.00
54	5"	C3513L-54	148	67.00	63.00	57.00	159	73.00	69.00	63.00
	6"	C3613L-54	165	67.00	63.00	57.00	178	73.00	69.00	63.00
60	5"	C3513L-60	159	73.00	69.00	63.00	171	79.00	75.00	69.00
	6"	C3613L-60	178	73.00	69.00	63.00	191	79.00	75.00	69.00

\* Weight includes pillow blocks (P-B22431H).

# Flat Belt Idlers

## rubber cushion rolls

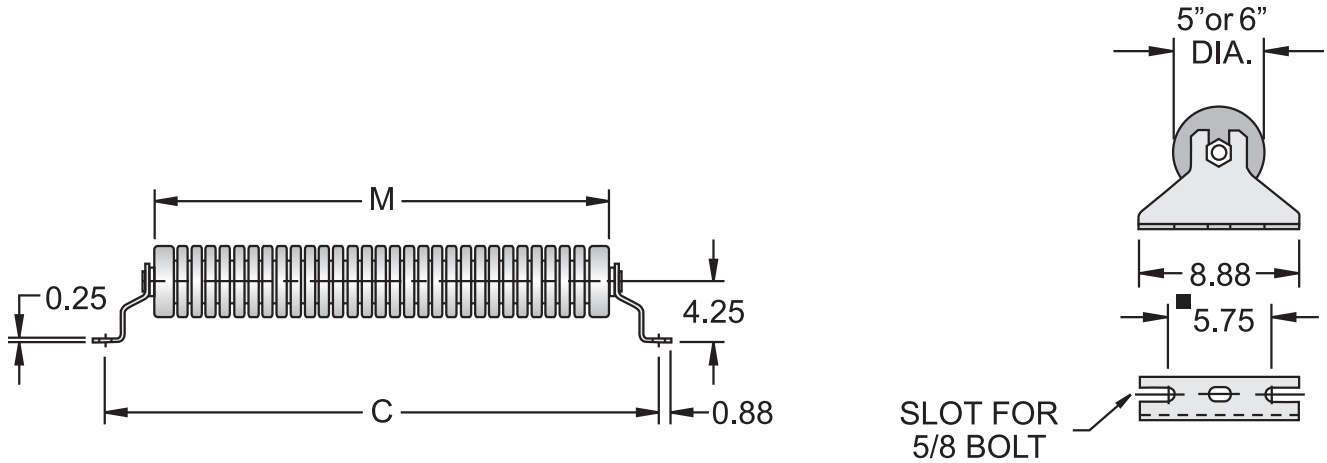

# CEMA C / D

Belt width, inches	Dia.	● Idler number	Standard Base (Belt width + 9")			Wide Base * (Belt width + 15")		
			Idler weight, pounds	C	M	Idler weight, pounds	C	M
				Inches			Inches	
18	5"	C3515S-18	28	27.00	20.25	34	33.00	26.25
	6"	C3615S-18	32	27.00	20.25	39	33.00	26.25
20	5"	C3515S-20	30	29.00	22.25	36	35.00	28.25
	6"	C3615S-20	35	29.00	22.25	42	35.00	28.25
24	5"	3515S-24	33	33.00	26.25	39	39.00	32.25
	6"	3615S-24	39	33.00	26.25	46	39.00	32.25
30	5"	3515S-30	39	39.00	32.25	45	45.00	38.25
	6"	3615S-30	46	39.00	32.25	53	45.00	38.25
36	5"	3515S-36	44	45.00	38.25	50	51.00	44.25
	6"	3615S-36	52	45.00	38.25	59	51.00	44.25
42	5"	3515S-42	50	51.00	44.25	56	57.00	50.25
	6"	3615S-42	62	51.00	44.25	69	57.00	50.25
48	5"	3515S-48	56	57.00	50.25	N/A	N/A	N/A
	6"	3615S-48	66	57.00	50.25	<i>Reference D3615S-48</i>		
48	6"	D3615S-48	67	57.00	50.25	75	63.00	56.25
54	6"	D3615S-54	75	63.00	56.25	85	69.00	62.25
60	6"	D3615S-60	82	69.00	62.25	100	75.00	68.25
72	6"	D3615S-72	97	81.00	74.25	N/A	N/A	N/A

■ 7.50" bolt spacing recommended.

\* For belt widths + 15" mounting above 42" use CEMA D.

● CEMA C or D are available in belt widths of 24" - 48".

# Flat Belt Idlers

rubber cushion rolls, live shaft type

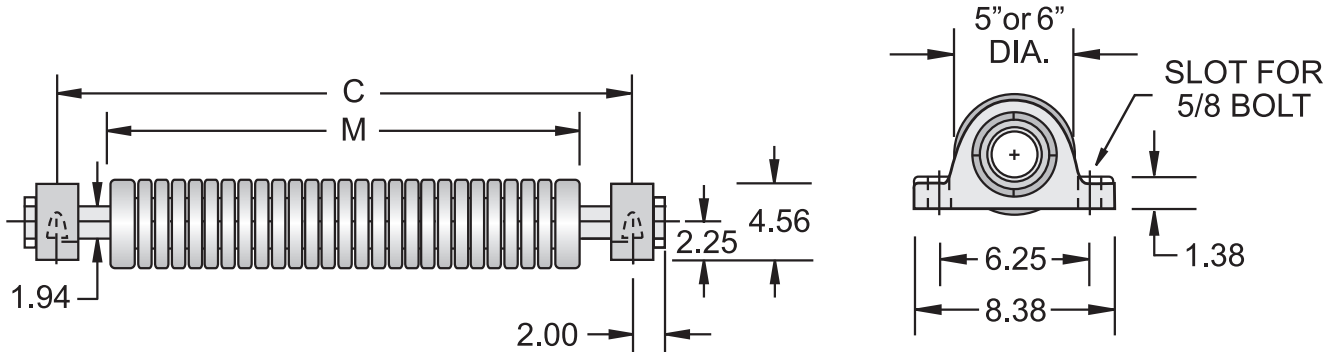

## CEMA C / D

Belt width, inches	Dia.	Idler number	Standard Base (Belt width + 9")			Wide Base (Belt width + 15")		
			Idler weight, pounds *	C	M	Idler weight, pounds *	C	M
				Inches			Inches	
18	5"	C3516-18	64	27.00	20.88	69	33.00	26.88
	6"	C3616-18	70	27.00	20.88	75	33.00	26.88
20	5"	C3516-20	67	29.00	22.88	72	35.00	28.88
	6"	C3616-20	74	29.00	22.88	79	35.00	28.88
24	5"	C3516-24	73	33.00	26.88	78	39.00	32.88
	6"	C3616-24	81	33.00	26.88	86	39.00	32.88
30	5"	C3516-30	81	39.00	32.88	87	45.00	38.88
	6"	C3616-30	91	39.00	32.88	97	45.00	38.88
36	5"	C3516-36	90	45.00	38.88	96	51.00	44.88
	6"	C3616-36	102	45.00	38.88	108	51.00	44.88
42	5"	C3516-42	99	51.00	44.88	105	57.00	50.88
	6"	C3616-42	112	51.00	44.88	118	57.00	50.88
48	5"	C3516-48	107	57.00	50.88	113	63.00	56.88
	6"	C3616-48	123	57.00	50.88	129	63.00	56.88
54	5"	C3516-54	116	63.00	56.88	123	69.00	62.88
	6"	C3616-54	133	63.00	56.88	140	69.00	62.88
60	5"	C3516-60	125	69.00	62.88	132	75.00	68.88
	6"	C3616-60	144	69.00	62.88	151	75.00	68.88

\* Weight includes pillow blocks (P-B22431H).

# Flat Belt Training Idlers

steel rolls, positive action type

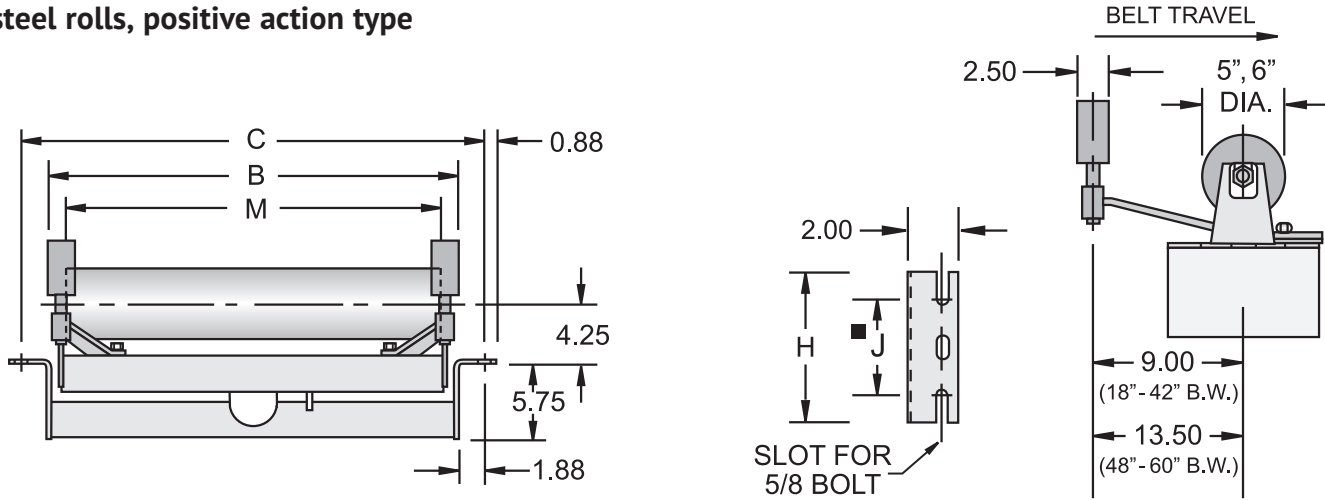

## CEMA C / D

Belt width, inches	Dia.	● Idler number	Standard Base (Belt width + 9")			Wide Base (Belt width + 15")			M	J	H
			Idler weight, pounds	B	C	Idler weight, pounds	B	C			
				Inches			Inches				
18	5"	C3514S-18	85	24.78	27.00	87	24.78	33.00	20.62	5.75	9.00
	6"	C3614S-18	90	24.78	27.00	92	24.78	33.00	20.62	5.75	9.00
20	5"	C3514S-20	89	26.78	29.00	91	26.78	35.00	22.62	5.75	9.00
	6"	C3614S-20	94	26.78	29.00	96	26.78	35.00	22.62	5.75	9.00
24	5"	3514S-24	98	30.78	33.00	100	30.78	39.00	26.62	5.75	9.00
	6"	3614S-24	104	30.78	33.00	106	30.78	39.00	26.62	5.75	9.00
30	5"	3514S-30	114	36.78	39.00	117	36.78	45.00	32.62	5.75	9.00
	6"	3614S-30	121	36.78	39.00	124	36.78	45.00	32.62	5.75	9.00
36	5"	3514S-36	128	42.78	45.00	131	42.78	51.00	38.62	5.75	9.00
	6"	3614S-36	136	42.78	45.00	139	42.78	51.00	38.62	5.75	9.00
42	5"	3514S-42	150	48.78	51.00	153	48.78	57.00	44.62	5.75	9.00
	6"	3614S-42	159	48.78	51.00	162	48.78	57.00	44.62	5.75	9.00
48	5"	3514S-48	165	54.78	57.00	168	54.78	63.00	50.62	5.75	9.00
	6"	3614S-48	175	54.78	57.00	178	54.78	63.00	50.62	5.75	9.00
54	5"	D3514S-54	183	60.78	63.00	191	60.78	69.00	56.62	6.75	10.00
	6"	D3614S-54	193	60.78	63.00	201	60.78	69.00	56.62	6.75	10.00
60	5"	D3514S-60	199	66.78	69.00	207	66.78	75.00	62.62	6.75	10.00
	6"	D3614S-60	211	66.78	69.00	218	66.78	75.00	62.62	6.75	10.00
66	5"	D3514S-66	215	72.78	75.00	223	72.78	81.00	68.62	6.75	10.00
	6"	D3614S-66	228	72.78	75.00	236	72.78	81.00	68.62	6.75	10.00
72	5"	D3514S-72	223	78.78	81.00	231	78.78	87.00	74.62	6.75	10.00
	6"	D3614S-72	233	78.78	81.00	241	78.78	87.00	74.62	6.75	10.00

■ Bolt spacing recommended to permit adjustment is (J + 1.75").  
 Example: If "J" = 5.75" then (5.75" + 1.75" = 7.5" bolt spacing).

● 1/4" thick rubber or urethane coated rolls, optional.  
 ● CEMA C or D are available in belt widths of 24" - 48".

# Return Belt Idlers

rubber tread rolls, massed ends

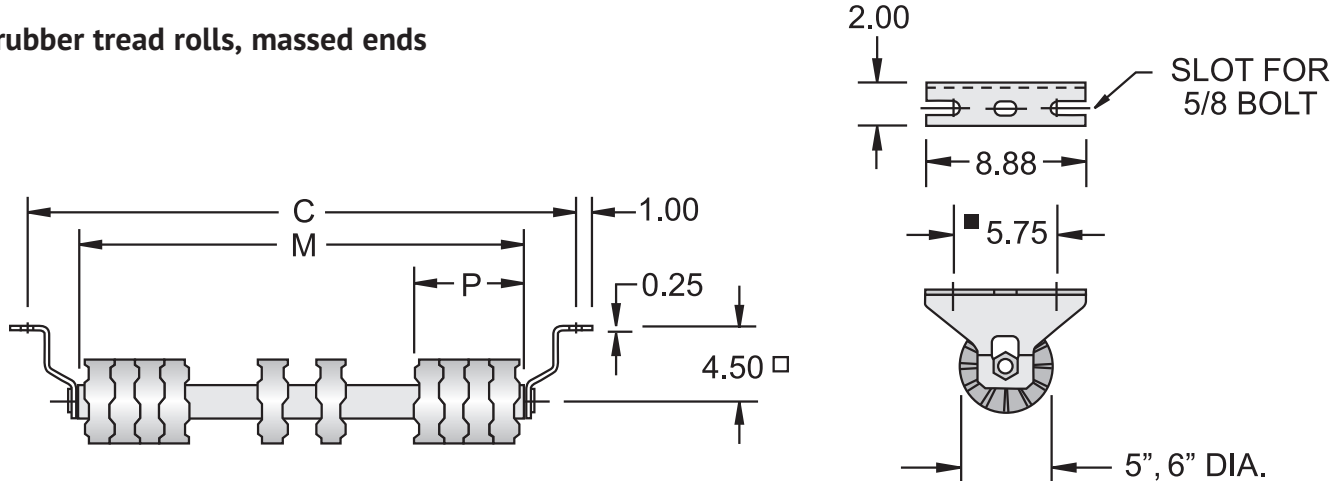

# CEMA C / D

Belt width, inches	Dia.	● Idler number	Standard Base (Belt width + 9")			Wide Base * (Belt width + 15")			Number of treads		
			Idler weight, pounds	C	M	P	Idler weight, pounds	C		M	P
				Inches				Inches			
18	5"	C3518S-18	27	27.00	20.75	6.62	33	33.00	26.75	9.62	9
	6"	C3618S-18 ▽	33	27.00	20.75	6.62	39	33.00	26.75	9.62	9
20	5"	C3518S-20	28	29.00	22.75	6.62	34	35.00	28.75	9.62	9
	6"	C3618S-20 ▽	34	29.00	22.75	6.62	40	35.00	28.75	9.62	9
24	5"	3518S-24	30	33.00	26.75	6.62	36	39.00	32.75	9.62	10
	6"	3618S-24 ▽	36	33.00	26.75	6.62	43	39.00	32.75	9.62	10
30	5"	3518S-30	34	39.00	32.75	6.62	41	45.00	38.75	9.62	11
	6"	3618S-30 ▽	41	39.00	32.75	6.62	48	45.00	38.75	9.62	11
36	5"	3518S-36	38	45.00	38.75	6.62	45	51.00	44.75	9.62	12
	6"	3618S-36 ▽	47	45.00	38.75	6.62	53	51.00	44.75	9.62	12
42	5"	3518S-42	41	51.00	44.75	6.62	48	57.00	50.75	9.62	13
	6"	3618S-42 ▽	49	51.00	44.75	6.62	56	57.00	50.75	9.62	13
48	5"	3518S-48	47	57.00	50.75	6.62	<i>Reference D3618S-48</i>			15	
	6"	3618S-48 ▽	57	57.00	50.75	6.62				15	
48	5"	D3518S-48	49	57.00	50.75	9.62	52	63.00	56.75	9.62	15
	6"	D3618S-48 ▽	59	57.00	50.75	9.62	61	63.00	56.75	9.62	15
54	5"	D3518S-54	65	63.00	56.75	9.62	68	69.00	62.75	9.62	16
	6"	D3618S-54 ▽	75	63.00	56.75	9.62	78	69.00	62.75	9.62	16
60	5"	D3518S-60	70	69.00	62.75	9.62	73	75.00	68.75	9.62	17
	6"	D3618S-60 ▽	82	69.00	62.75	9.62	85	75.00	68.75	9.62	17
72	5"	D3518S-72	95	81.00	74.75	9.62	98	87.00	80.75	9.62	19
	6"	D3618S-72 ▽	119	81.00	74.75	9.62	122	87.00	80.75	9.62	19

■ 7.50" bolt spacing recommended.

□ 1.5" drop can be furnished if specified.

▽ 6" diameter urethane treads available.

\* For belt widths + 15" mounting above 42" use CEMA D.

● CEMA C or D are available in belt widths of 24" - 48".

# Return Belt Idlers

steel rolls

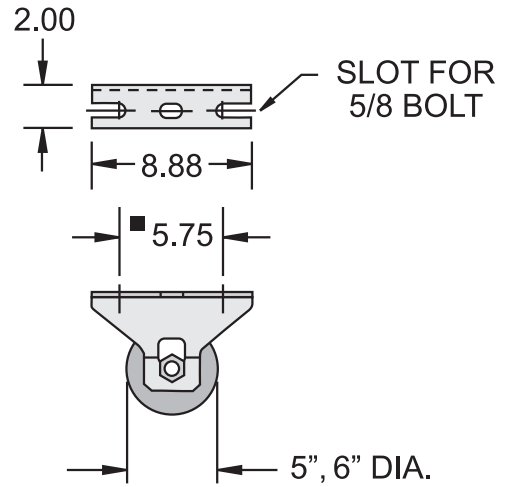
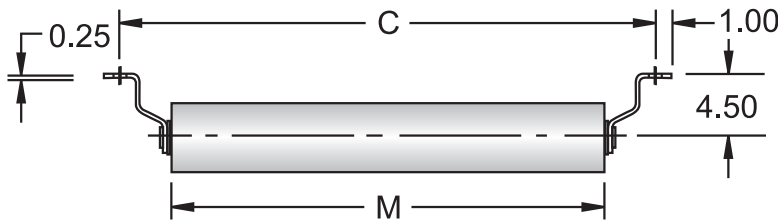

# CEMA C / D

Belt width, inches	Dia.	● * Idler number	Standard Base (Belt width + 9")			Wide Base (Belt width + 15")		
			Idler weight, pounds	C	M	Idler weight, pounds	C	M
				Inches			Inches	
18	5"	C3517S-18	30	27.00	20.62	38	33.00	26.62
	6"	C3617S-18	35	27.00	20.62	45	33.00	26.62
20	5"	C3517S-20	32	29.00	22.62	40	35.00	28.62
	6"	C3617S-20	38	29.00	22.62	48	35.00	28.62
24	5"	3517S-24	36	33.00	26.62	44	39.00	32.62
	6"	3617S-24	42	33.00	26.62	52	39.00	32.62
30	5"	3517S-30	42	39.00	32.62	50	45.00	38.62
	6"	3617S-30	50	39.00	32.62	60	45.00	38.62
36	5"	3517S-36	48	45.00	38.62	56	51.00	44.62
	6"	3617S-36	58	45.00	38.62	68	51.00	44.62
42	5"	3517S-42	53	51.00	44.62	61	57.00	50.62
	6"	3617S-42	63	51.00	44.62	73	57.00	50.62
48	5"	3517S-48	60	57.00	50.62	<i>Reference D3617S-48</i>		
	6"	3617S-48	72	57.00	50.62			
48	5"	D3517S-48	62	57.00	50.62	88	63.00	56.62
	6"	D3617S-48	74	57.00	50.62	102	63.00	56.62
54	5"	D3517S-54	88	63.00	56.62	98	69.00	62.62
	6"	D3617S-54	101	63.00	56.62	113	69.00	62.62
60	5"	D3517S-60	98	69.00	62.62	108	75.00	68.62
	6"	D3617S-60	111	69.00	62.62	123	75.00	68.62
72	5"	D3517S-72	122	81.00	74.62	133	87.00	80.62
	6"	D3617S-72	134	81.00	74.62	147	87.00	80.62

■ 7.50" bolt spacing recommended.

□ 1.5" drop can be furnished if specified.

\* For belt widths + 15" mounting above 42" use CEMA D and next higher belt width.

● 1/4" thick rubber or urethane coated rolls, optional.

● CEMA C or D are available in belt widths of 24" - 48".

# Return Belt Beater Idlers

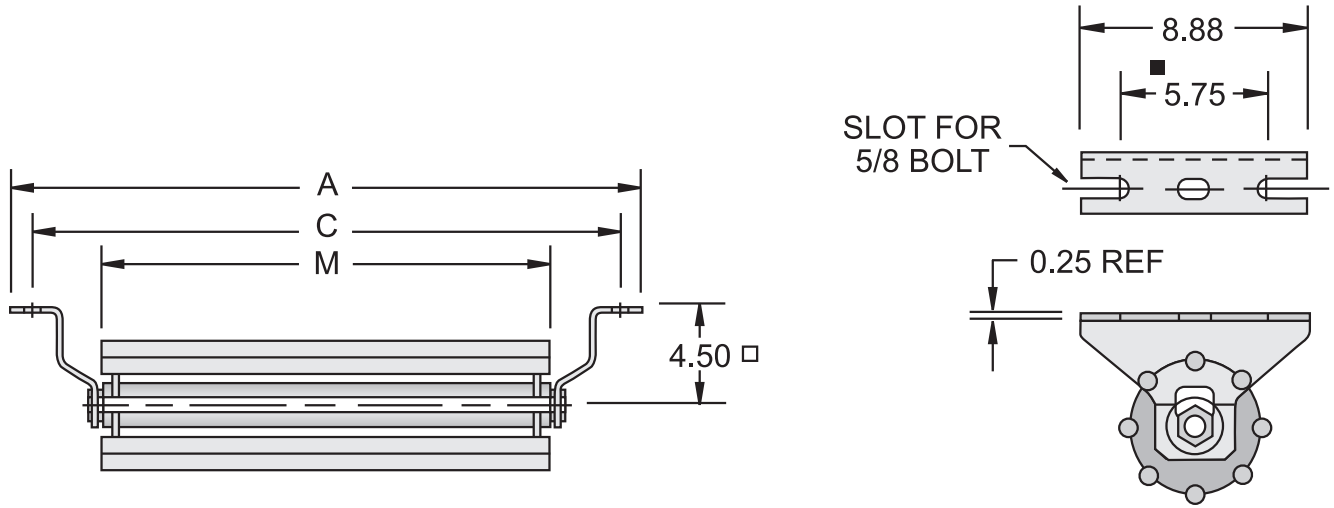

## CEMA C / D

Belt width, inches	Dia.	● Idler number	Standard Base (Belt width + 9")			Wide Base* (Belt width + 15")				
			Idler weight, pounds	A	C	M	Idler weight, pounds	A	C	M
				Inches				Inches		
18	6"	C3619S-18	46	29.00	27.00	20.62	59	35.00	33.00	26.62
20	6"	C3619S-20	50	31.00	29.00	22.62	62	37.00	35.00	28.62
24	6"	3619S-24	59	35.00	33.00	26.62	68	41.00	39.00	32.62
30	6"	3619S-30	68	41.00	39.00	32.62	80	47.00	45.00	38.62
36	6"	3619S-36	80	47.00	45.00	38.62	99	53.00	51.00	44.62
42	6"	3619S-42	99	53.00	51.00	44.62	109	59.00	57.00	50.62
48	6"	3619S-48	109	59.00	57.00	50.62	<i>Reference D3619S-48</i>			
48	6"	D3619S-48	104	59.00	57.00	50.62	135	65.00	63.00	56.62
54	6"	D3619S-54	135	65.00	63.00	56.62	149	71.00	69.00	62.62
60	6"	D3619S-60	149	71.00	69.00	62.62	163	77.00	75.00	68.62

- 7.50" bolt spacing recommended.
- 1.5" drop can be furnished if specified.
- \* For belt widths + 15" mounting above 42" use CEMA D and next higher belt width.
- CEMA C or D are available in belt widths of 24" - 48".



# Return Belt Training Idlers

steel rolls, positive action type

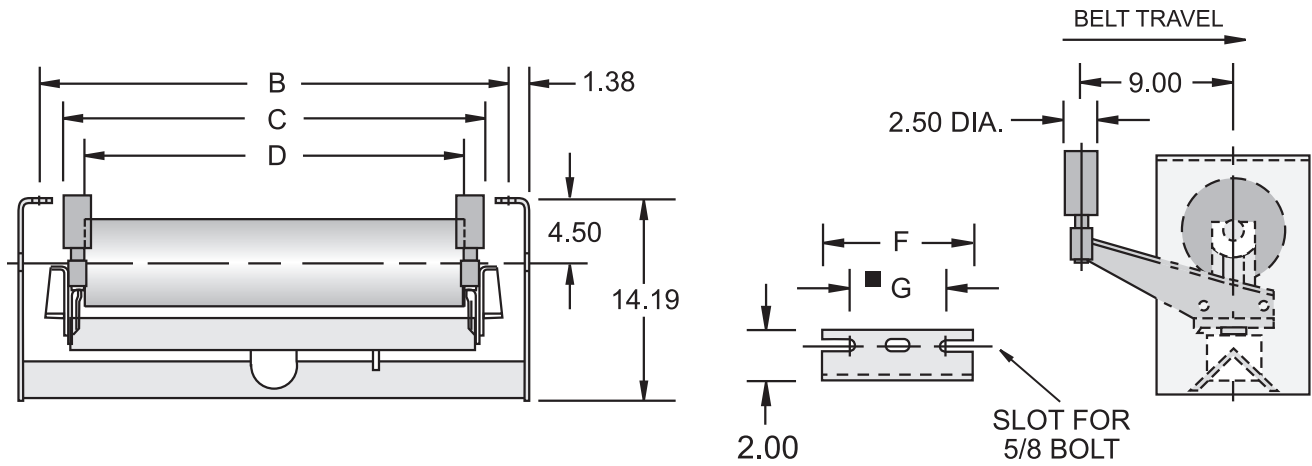

## CEMA C / D

Belt width, inches	Dia.	● Idler number	Standard Base (Belt width + 9")		Wide Base (Belt width + 15")		C	D	G	F
			Idler weight, pounds	B	Idler weight, pounds	B				
18	5"	C3520S-18	95	27.00	97	33.00	23.56	20.62	5.75	9.00
	6"	C3620S-18	100	27.00	103	33.00	23.56	20.62	5.75	9.00
20	5"	C3520S-20	99	29.00	101	35.00	25.56	22.62	5.75	9.00
	6"	C3620S-20	105	29.00	107	35.00	25.56	22.62	5.75	9.00
24	5"	3520S-24	106	33.00	108	39.00	29.56	26.62	5.75	9.00
	6"	3620S-24	113	33.00	116	39.00	29.56	26.62	5.75	9.00
30	5"	3520S-30	122	39.00	125	45.00	35.56	32.62	5.75	9.00
	6"	3620S-30	130	39.00	133	45.00	35.56	32.62	5.75	9.00
36	5"	3520S-36	134	45.00	137	51.00	41.56	38.62	5.75	9.00
	6"	3620S-36	144	45.00	147	51.00	41.56	38.62	5.75	9.00
42	5"	3520S-42	154	51.00	158	57.00	47.56	44.62	5.75	9.00
	6"	3620S-42	165	51.00	168	57.00	47.56	44.62	5.75	9.00
48	5"	3520S-48	170	57.00	174	63.00	53.56	50.62	5.75	9.00
	6"	3620S-48	182	57.00	186	63.00	53.56	50.62	5.75	9.00
48	5"	D3520S-48	172	57.00	176	63.00	53.56	50.62	5.75	9.00
	6"	D3620S-48	184	57.00	188	63.00	53.56	50.62	5.75	9.00
54	5"	D3520S-54	206	63.00	210	69.00	59.56	56.62	6.75	10.00
	6"	D3620S-54	220	63.00	224	69.00	59.56	56.62	6.75	10.00
60	5"	D3520S-60	228	69.00	232	75.00	65.56	62.62	6.75	10.00
	6"	D3620S-60	242	69.00	245	75.00	65.56	62.62	6.75	10.00
72	5"	D3520S-72	252	81.00	256	87.00	77.56	74.62	6.75	10.00
	6"	D3620S-72	264	81.00	267	87.00	77.56	74.62	6.75	10.00

■ Bolt spacing recommended to permit adjustment is (G + 1.75").  
 Example: If "G" = 5.75" then (5.75" + 1.75" = 7.5" bolt spacing).

● 1/4" thick rubber or urethane coated rolls, optional.  
 ● CEMA C or D are available in belt widths of 24" - 48".

\* 1.5" drop can be furnished if specified.

# Return Belt Training Idlers

rubber tread rolls, positive action type, massed ends

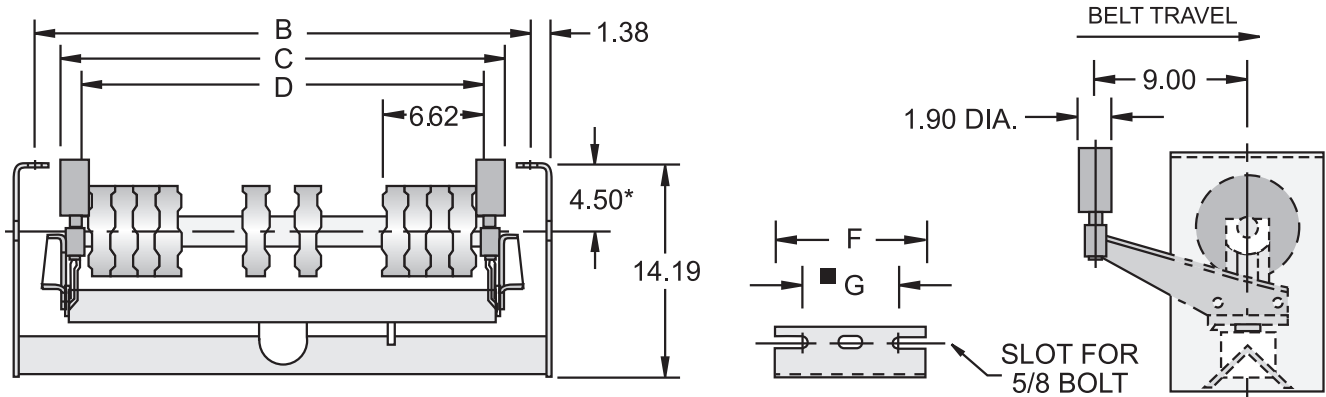

## CEMA C / D

Belt width, inches	Dia.	● Idler number	Standard Base (Belt width + 9")		Wide Base (Belt width + 15")		C	D	Number of treads	G	F
			Idler weight, pounds	B	Idler weight, pounds	B					
							Inches			Inches	
18	5"	C3521S-18	91	27.00	93	33.00	23.56	20.75	9	5.75	9.00
	6"	C3621S-18 ▽	97	27.00	99	33.00	23.56	20.75	9	5.75	9.00
20	5"	C3521S-20	94	29.00	96	35.00	25.56	22.75	9	5.75	9.00
	6"	C3621S-20 ▽	100	29.00	102	35.00	25.56	22.75	9	5.75	9.00
24	5"	3521S-24	101	33.00	103	39.00	29.56	26.75	10	5.75	9.00
	6"	3621S-24 ▽	107	33.00	110	39.00	29.56	26.75	10	5.75	9.00
30	5"	3521S-30	114	39.00	118	45.00	35.56	32.75	11	5.75	9.00
	6"	3621S-30 ▽	121	39.00	125	45.00	35.56	32.75	11	5.75	9.00
36	5"	3521S-36	124	45.00	128	51.00	41.56	38.75	12	5.75	9.00
	6"	3621S-36 ▽	133	45.00	136	51.00	41.56	38.75	12	5.75	9.00
42	5"	3521S-42	143	51.00	147	57.00	47.56	44.75	13	5.75	9.00
	6"	3621S-42 ▽	151	51.00	155	57.00	47.56	44.75	13	5.75	9.00
48	5"	C3521S-48	157	57.00	161	63.00	53.56	50.75	15	5.75	9.00
	6"	C3621S-48 ▽	167	57.00	170	63.00	53.56	50.75	15	5.75	9.00
48	5"	D3521S-48	159	57.00	163	63.00	53.56	50.75	15	5.75	9.00
	6"	D3621S-48 ▽	169	57.00	173	63.00	53.56	50.75	15	5.75	9.00
54	5"	D3521S-54	182	63.00	186	69.00	59.56	56.75	16	6.75	10.00
	6"	D3621S-54 ▽	192	63.00	196	69.00	59.56	56.75	16	6.75	10.00
60	5"	D3521S-60	200	69.00	204	75.00	65.56	62.75	17	6.75	10.00
	6"	D3621S-60 ▽	212	69.00	216	75.00	65.56	62.75	17	6.75	10.00
72	5"	D3521S-72	225	81.00	229	87.00	77.56	74.75	19	6.75	10.00
	6"	D3621S-72 ▽	239	81.00	243	87.00	77.56	74.75	19	6.75	10.00

■ Bolt spacing recommended to permit adjustment is (G + 1.75").

● CEMA C or D are available in belt widths of 24" - 42".

Example: If "G" = 5.75" then (5.75" + 1.75" = 7.5" bolt spacing).

\* 1.5" drop can be furnished if specified.

▽ 6" diameter urethane treads available.

# Return Belt Training Idlers

steel rolls, actuating shoe type, reversing belts

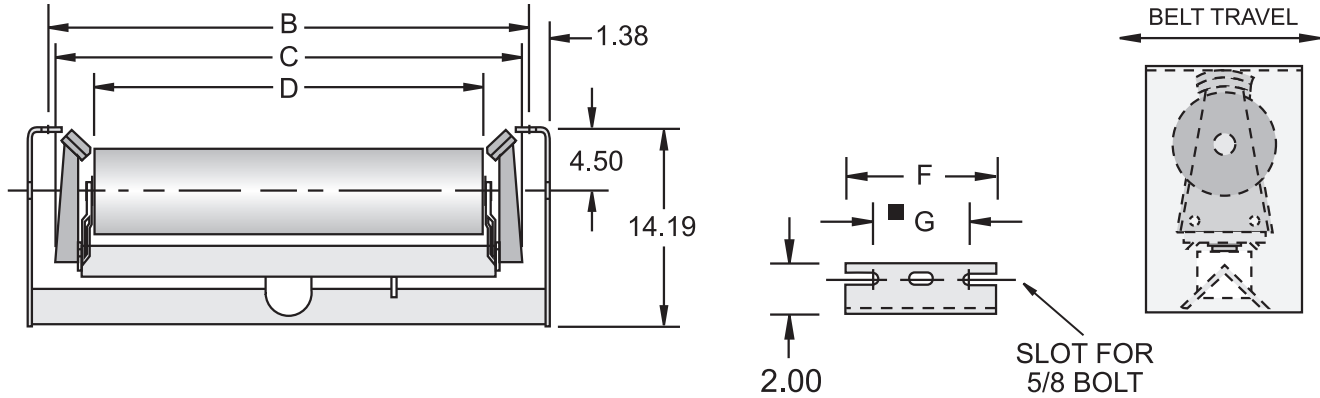

## CEMA C / D

Belt width, inches	Dia.	● Idler number	Standard Base (Belt width + 9")		Wide Base (Belt width + 15")		C	D	G	F
			Idler weight, pounds	B	Idler weight, pounds	B				
18	5"	C3526S-18	85	27.00	87	33.00	26.00	20.62	5.75	9.00
	6"	C3626S-18	90	27.00	93	33.00	26.00	20.62	5.75	9.00
20	5"	C3526S-20	89	29.00	91	35.00	28.00	22.62	5.75	9.00
	6"	C3626S-20	95	29.00	97	35.00	28.00	22.62	5.75	9.00
24	5"	3526S-24	96	33.00	98	39.00	32.00	26.62	5.75	9.00
	6"	3626S-24	103	33.00	106	39.00	32.00	26.62	5.75	9.00
30	5"	3526S-30	112	39.00	115	45.00	38.00	32.62	5.75	9.00
	6"	3626S-30	120	39.00	123	45.00	38.00	32.62	5.75	9.00
36	5"	3526S-36	124	45.00	127	51.00	44.00	38.62	5.75	9.00
	6"	3626S-36	134	45.00	137	51.00	44.00	38.62	5.75	9.00
42	5"	3526S-42	144	51.00	148	57.00	50.00	44.62	5.75	9.00
	6"	3626S-42	155	51.00	158	57.00	50.00	44.62	5.75	9.00
48	5"	3526S-48	160	57.00	164	63.00	56.00	50.62	5.75	9.00
	6"	3626S-48	172	57.00	176	63.00	56.00	50.62	5.75	9.00
54	5"	D3526S-54	196	63.00	200	69.00	62.00	56.62	6.75	10.00
	6"	D3626S-54	210	63.00	214	69.00	62.00	56.62	6.75	10.00
60	5"	D3526S-60	218	69.00	222	75.00	68.00	62.62	6.75	10.00
	6"	D3626S-60	232	69.00	236	75.00	68.00	62.62	6.75	10.00
72	5"	D3526S-72	242	81.00	246	87.00	80.00	74.62	6.75	10.00
	6"	D3626S-72	254	81.00	258	87.00	80.00	74.62	6.75	10.00

■ Bolt spacing recommended to permit adjustment is (G + 1.75").  
 Example: If "G" = 5.75" then (5.75" + 1.75" = 7.5" bolt spacing).

- CEMA C or D are available in belt widths of 24" - 48".
- 1/4" thick rubber or urethane coated rolls, optional.

# Return Belt Training Idlers

rubber tread rolls, actuating shoe type – reversing belts, massed ends

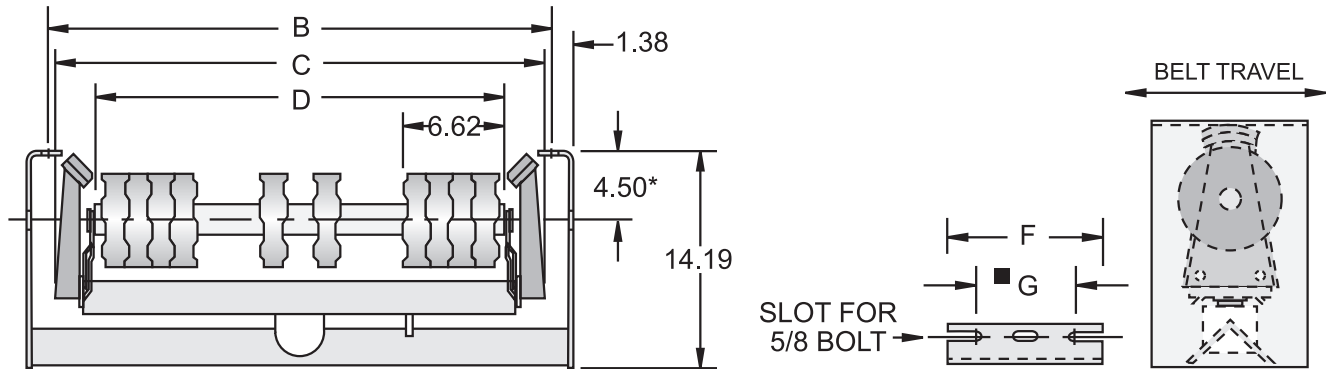

## CEMA C / D

Belt width, inches	Dia.	● Idler number	Standard Base (Belt width + 9")		Wide Base (Belt width + 15")		C	D	Number of treads	G	F
			Idler weight, pounds	B	Idler weight, pounds	B					
18	5"	C3527S-18	81	27.00	83	33.00	26.00	20.75	9	5.75	9.00
	6"	C3627S-18 ▽	87	27.00	89	33.00	26.00	20.75	9	5.75	9.00
20	5"	C3527S-20	84	29.00	86	35.00	28.00	22.75	9	5.75	9.00
	6"	C3627S-20 ▽	90	29.00	92	35.00	28.00	22.75	9	5.75	9.00
24	5"	3527S-24	91	33.00	93	39.00	32.00	26.75	10	5.75	9.00
	6"	3627S-24 ▽	97	33.00	100	39.00	32.00	26.75	10	5.75	9.00
30	5"	3527S-30	104	39.00	108	45.00	38.00	32.75	11	5.75	9.00
	6"	3627S-30 ▽	111	39.00	115	45.00	38.00	32.75	11	5.75	9.00
36	5"	3527S-36	114	45.00	118	51.00	44.00	38.75	12	5.75	9.00
	6"	3627S-36 ▽	123	45.00	126	51.00	44.00	38.75	12	5.75	9.00
42	5"	3527S-42	133	51.00	137	57.00	50.00	44.75	13	5.75	9.00
	6"	3627S-42 ▽	141	51.00	145	57.00	50.00	44.75	13	5.75	9.00
48	5"	C3527S-48	147	57.00	151	63.00	56.00	50.75	15	5.75	9.00
	6"	C3627S-48 ▽	157	57.00	160	63.00	56.00	50.75	15	5.75	9.00
48	5"	D3527S-48	149	57.00	153	63.00	56.00	50.75	15	5.75	9.00
	6"	D3627S-48 ▽	159	57.00	163	63.00	56.00	50.75	15	5.75	9.00
54	5"	D3527S-54	172	63.00	176	69.00	62.00	56.75	16	6.75	10.00
	6"	D3627S-54 ▽	182	63.00	186	69.00	62.00	56.75	16	6.75	10.00
60	5"	D3527S-60	190	69.00	194	75.00	68.00	62.75	17	6.75	10.00
	6"	D3627S-60 ▽	202	69.00	206	75.00	68.00	62.75	17	6.75	10.00
72	5"	D3527S-72	215	81.00	219	87.00	80.00	74.75	19	6.75	10.00
	6"	D3627S-72 ▽	229	81.00	233	87.00	80.00	74.75	19	6.75	10.00

■ Bolt spacing recommended to permit adjustment is (G + 1.75").

\* 1.5" drop can be furnished if specified.

Example: If "G" = 5.75" then (5.75" + 1.75" = 7.5" bolt spacing).

● CEMA C or D are available in belt widths of 24" - 48".

▽ 6" diameter urethane treads available.

# 10° V-Return Idlers

steel rolls, v-return

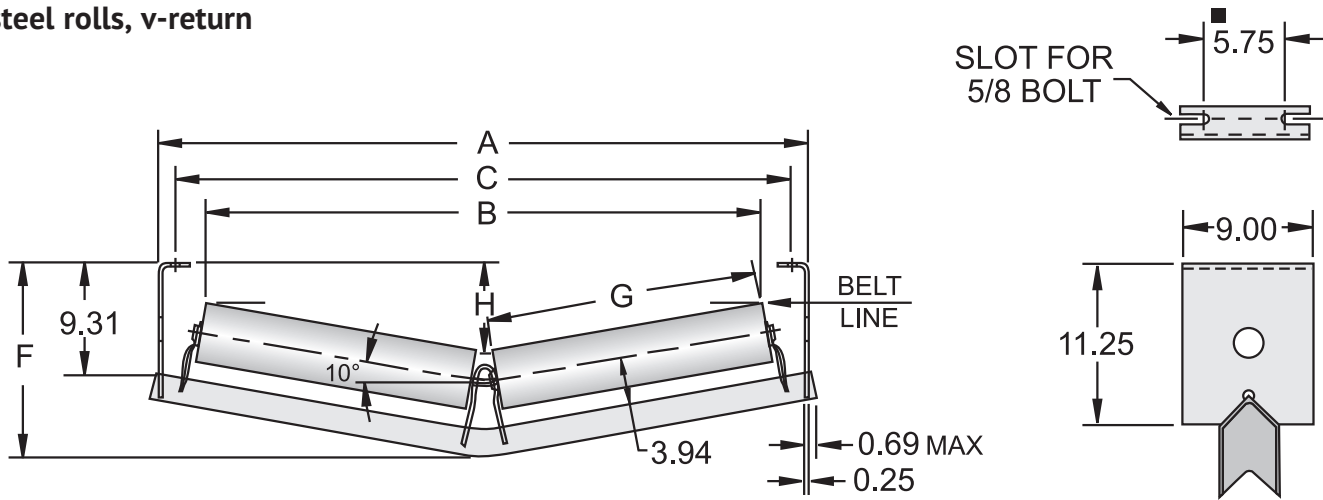

## CEMA C / D

** Belt width, inches	Dia.	● Idler number	Idler weight, pounds	A	B	C	F	G	H
				Inches					
24	5"	C3565S-24	78	35.75	26.62	33.00	14.62	12.81	5.88
	6"	C3665S-24	83	35.75	26.44	33.00	14.62	12.81	5.38
30	5"	C3565S-30	86	41.75	32.88	39.00	15.12	16.00	6.38
	6"	C3665S-30	92	41.75	32.75	39.00	15.12	16.00	5.88
36	5"	3565S-36	94	47.75	39.19	45.00	15.69	19.19	6.94
	6"	3665S-36	101	47.75	39.00	45.00	15.69	19.19	6.44
42	5"	3565S-42	109	53.75	45.94	51.00	16.25	22.62	7.44
	6"	3665S-42	116	53.75	45.75	51.00	16.25	22.62	6.94
48	5"	3565S-48	117	59.75	51.88	57.00	16.75	25.62	8.00
	6"	3665S-48	125	59.75	51.69	57.00	16.75	25.62	7.50
54	5"	3565S-54	125	65.75	57.75	63.00	17.31	28.62	8.50
	6"	3665S-54	134	65.75	57.56	63.00	17.31	28.62	8.00
60	5"	3565S-60	139	71.75	63.69	69.00	18.12	31.62	9.06
	6"	3665S-60	148	71.75	63.50	69.00	18.12	31.62	8.50
66	5"	3565S-66	148	77.75	69.56	75.00	18.62	34.62	9.56
	6"	3665S-66	158	77.75	69.38	75.00	18.62	34.62	9.06
72	5"	D3565S-72	103	83.75	75.50	81.00	19.56	37.62	10.12
	6"	D3665S-72	148	83.75	75.31	81.00	19.56	37.62	9.56
78	5"	D3565S-78	103	89.75	81.38	87.00	20.12	40.62	10.62
	6"	D3665S-78	158	89.75	81.25	87.00	20.12	40.62	10.12

■ 7.50" bolt spacing recommended.

● 1/4" thick rubber or urethane coated rolls, optional.

\*\* For belt width + 15" mounting use next higher belt width.

● CEMA C or D are available in belt widths of 36" - 66".

# 15° V-Return Idlers

steel rolls, v-return

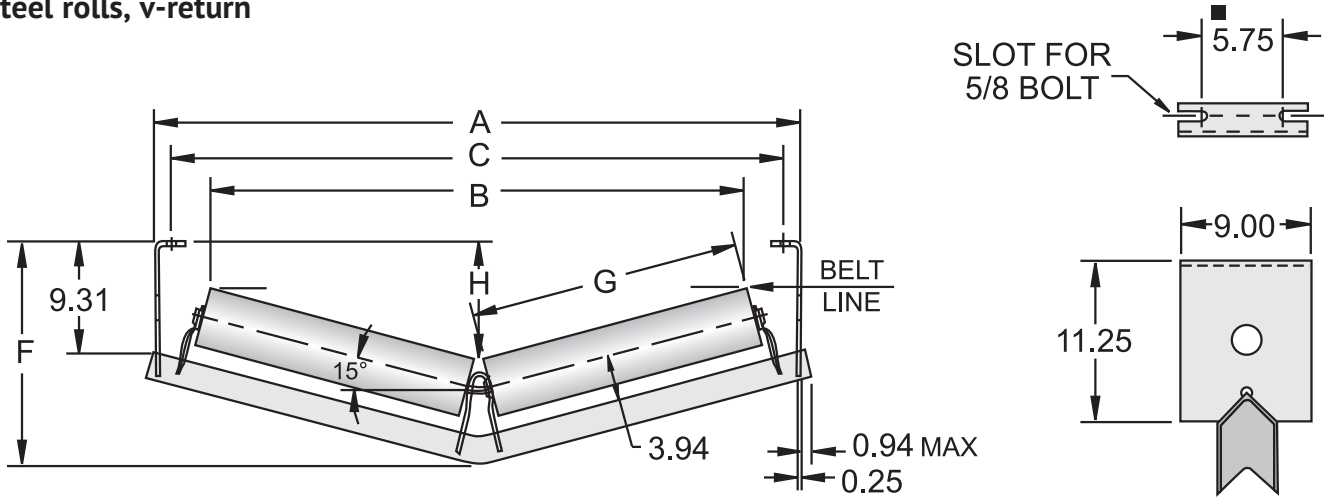

## CEMA C / D

** Belt width, inches	Dia.	● Idler number	Idler weight, pounds	A	B	C	F	G	H
				Inches					
24	5"	C3566S-24	78	35.75	25.62	33.00	16.19	12.81	7.38
	6"	C3666S-24	83	35.75	25.38	33.00	16.19	12.81	6.88
30	5"	C3566S-30	86	41.75	31.81	39.00	17.00	16.00	8.19
	6"	C3666S-30	92	41.75	31.56	39.00	17.00	16.00	7.62
36	5"	3566S-36	94	47.75	37.94	45.00	17.81	19.19	9.00
	6"	3666S-36	101	47.75	37.69	45.00	17.81	19.19	8.44
42	5"	3566S-42	109	53.75	44.56	51.00	18.69	22.62	9.75
	6"	3666S-42	116	53.75	44.31	51.00	18.69	22.62	9.25
48	5"	3566S-48	117	59.75	50.38	57.00	19.44	25.62	10.56
	6"	3666S-48	125	59.75	50.12	57.00	19.44	25.62	10.06
54	5"	3566S-54	125	65.75	56.18	63.00	20.25	28.62	11.38
	6"	3666S-54	134	65.75	55.94	63.00	20.25	28.62	10.88
60	5"	3566S-60	139	71.75	61.94	69.00	21.38	31.62	12.19
	6"	3666S-60	148	71.75	61.69	69.00	21.38	31.62	11.69
66	5"	3566S-66	148	77.75	67.75	75.00	22.19	34.62	13.00
	6"	3666S-66	158	77.75	67.50	75.00	22.19	34.62	12.50
72	5"	D3566S-72	163	83.75	73.56	81.00	23.38	37.62	13.81
	6"	D3666S-72	174	83.75	73.31	81.00	23.38	37.62	13.31
78	5"	D3566S-78	185	89.75	79.38	87.00	24.25	40.62	14.62
	6"	D3666S-78	197	89.75	79.12	87.00	24.25	40.62	14.06

■ 7.50" bolt spacing recommended.

● 1/4" thick rubber or urethane coated rolls, optional.

\*\* For belt width + 15" mounting use next higher belt width.

● CEMA C or D are available in belt widths of 36" - 66".

# 10° V-Return Idlers

rubber tread rolls, v-return, massed ends

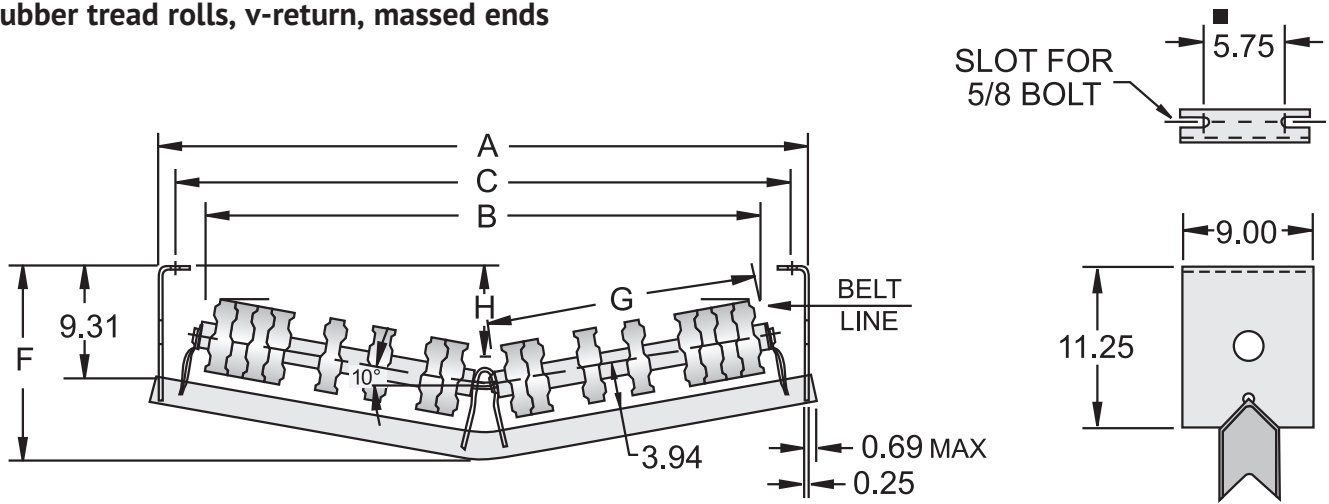

## CEMA C / D

** Belt width, inches	Dia.	● Idler number	Idler weight, pounds	A	B	C	F	G	H
				Inches					
24	6"	C3668S-24	86	35.75	24.44	33.00	14.62	12.69	5.38
30	6"	C3668S-30	91	41.75	30.69	39.00	15.12	15.88	5.88
36	6"	3668S-36	99	47.75	36.50	45.00	15.69	19.06	6.44
42	6"	3668S-42	114	53.75	43.75	51.00	16.25	22.75	6.94
48	6"	3668S-48	119	59.75	49.62	57.00	16.75	25.75	7.50
54	6"	3668S-54	136	65.75	55.50	63.00	17.31	28.75	8.00
60	6"	3668S-60	146	71.75	61.43	69.00	18.12	31.75	8.50
66	6"	3668S-66	152	77.75	67.88	75.00	18.62	34.75	9.06
72	6"	D3668S-72	170	83.75	73.75	81.00	19.56	37.75	9.56
78	6"	D3668S-78	189	89.75	79.69	87.00	20.12	40.75	10.12

■ 7.50" bolt spacing recommended.

● CEMA C or D are available in belt widths of 36" - 66".

\*\* For belt width + 15" mounting use next higher belt width.

# 15° V-Return Idlers

rubber tread rolls, v-return, massed ends

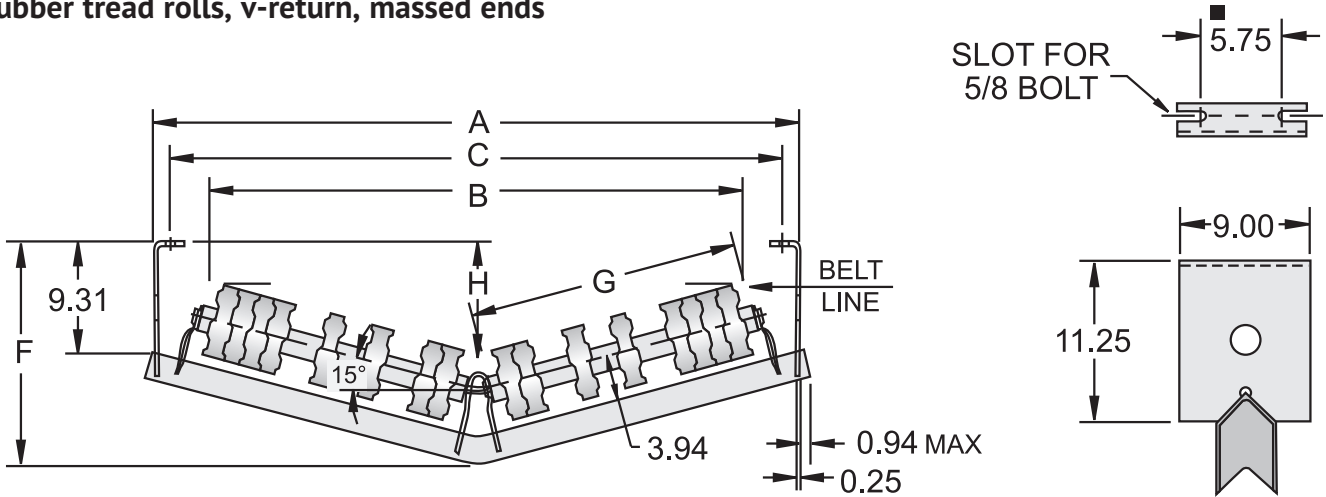

## CEMA C / D

** Belt width, inches	Dia.	● Idler number	Idler weight, pounds	A	B	C	F	G	H
				Inches					
24	6"	C3669S-24	86	35.75	23.38	33.00	16.19	12.69	6.88
30	6"	C3669S-30	91	41.75	29.56	39.00	17.00	15.88	7.62
36	6"	3669S-36	99	47.75	35.25	45.00	17.81	19.06	8.44
42	6"	3669S-42	114	53.75	42.31	51.00	18.69	22.75	9.25
48	6"	3669S-48	119	59.75	48.12	57.00	19.44	25.75	10.06
54	6"	3669S-54	136	65.75	53.94	63.00	20.25	28.75	10.88
60	6"	3669S-60	146	71.75	59.69	69.00	21.38	31.75	11.69
66	6"	3669S-66	152	77.75	66.00	75.00	22.19	34.75	12.50
72	6"	D3669S-72	170	83.75	71.75	81.00	23.38	37.75	13.31
78	6"	D3669S-78	189	89.75	77.56	87.00	24.25	40.75	14.06

■ 7.50" bolt spacing recommended.

● CEMA C or D are available in belt widths of 36" - 66".

\*\* For belt width + 15" mounting use next higher belt width.



# Ordering Replacement Rolls

Below are the part numbers to reference when ordering sealed replacement rolls for CEMA Series C3000 and D3000. If regreasable rolls are required, drop the "S" suffix in the part number. Frame is not included.

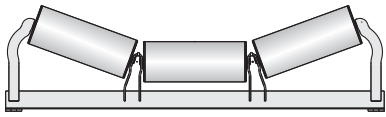

The following part numbers fit

**5" diameter steel troughing rolls for 3501S, 3502S, 3506S, 3507S, 3508S, 3509S, 3511S, 3528S, 3532S and 3537S idlers**

## C3500 Replacement Rolls

## D3500 Replacement Rolls

Belt Width	Part Number	Belt Width	Part Number
18	1730-281-A.S.	-	-
20	1730-281-B.S.	-	-
24	1730-281-C.S.	24	1730-281-C.S.
30	1730-281-D.S.	30	1730-281-D.S.
36	1730-281-E.S.	36	1730-281-E.S.
42	1730-281-F.S.	42	1730-281-F.S.
48	1730-281-G.S.	48	1730-281-G.S.
54	1730-281-H.S.	54	1730-281-H.S.
60	1730-281-J.S.	60	1730-281-J.S.
-	-	72	1730-341-V.S.

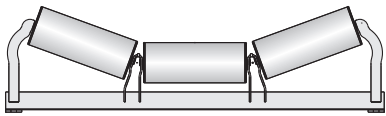

The following part numbers fit

**6" diameter steel troughing rolls for 3601S, 3602S, 3606S, 3607S, 3608S, 3609S, 3611S, 3628S, 3632S and 3637S idlers**

## C3600 Replacement Rolls

## D3600 Replacement Rolls

Belt Width	Part Number	Belt Width	Part Number
18	1730-285-A.S.	-	-
20	1730-285-B.S.	-	-
24	1730-285-C.S.	24	1730-285-C.S.
30	1730-285-D.S.	30	1730-285-D.S.
36	1730-285-E.S.	36	1730-285-E.S.
42	1730-285-F.S.	42	1730-285-F.S.
48	1730-285-G.S.	48	1730-285-G.S.
54	1730-285-H.S.	54	1730-285-H.S.
60	1730-285-J.S.	60	1730-285-J.S.
-	-	72	1730-342-V.S.

# Ordering Replacement Rolls

Below are the part numbers to reference when ordering sealed replacement rolls for CEMA Series C3000 and D3000. If regreasable rolls are required, drop the "S" suffix in the part number. Frame is not included.

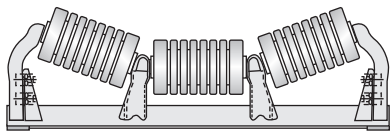

The following part numbers fit

**5"** diameter rubber cushion troughing rolls for 3504S, 3523S and 3530S idlers

## C3500 Replacement Rolls

Belt Width	Part Number
18	1730-327-A.S.
20	1730-327-B.S.
24	1730-327-C.S.
30	1730-327-D.S.
36	1730-327-E.S.
42	1730-327-F.S.
48	1730-327-G.S.
54	1730-327-H.S.
60	1730-327-J.S.
-	-

## D3500 Replacement Rolls

Belt Width	Part Number
-	-
-	-
24	1730-327-C.S.
30	1730-327-D.S.
36	1730-327-E.S.
42	1730-327-F.S.
48	1730-327-G.S.
54	1730-327-H.S.
60	1730-327-J.S.
72	1730-404-K.S.

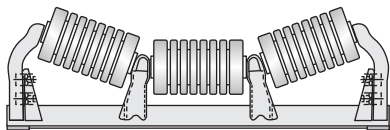

The following part numbers fit

**6"** diameter rubber cushion troughing rolls for 3604S, 3623S and 3630S idlers

## C3600 Replacement Rolls

Belt Width	Part Number
18	1730-326-A.S.
20	1730-326-B.S.
24	1730-326-C.S.
30	1730-326-D.S.
36	1730-326-E.S.
42	1730-326-F.S.
48	1730-326-G.S.
54	1730-326-H.S.
60	1730-326-J.S.
-	-

## D3600 Replacement Rolls

Belt Width	Part Number
-	-
-	-
24	1730-326-C.S.
30	1730-326-D.S.
36	1730-326-E.S.
42	1730-326-F.S.
48	1730-326-G.S.
54	1730-326-H.S.
60	1730-326-J.S.
72	1730-361-F.S.

# Ordering Replacement Rolls

Below are the part numbers to reference when ordering sealed replacement rolls for CEMA Series C3000 and D3000. If regreasable rolls are required, drop the "S" suffix in the part number. Frame is not included.



The following part numbers fit  
**5" diameter steel return/carrying rolls for 3513S, 3514S, 3517S, 3520S and 3526S idlers**

## C3500 Replacement Rolls

Belt Width	Part Number
18	1730-281-AE.S.
20	1730-281-AF.S.
24	1730-281-AG.S.
30	1730-281-AH.S.
36	1730-281-AJ.S.
42	1730-281-AK.S.
48	1730-281-AL.S.
-	-
-	-
-	-
-	-
-	-

## D3500 Replacement Rolls

Belt Width	Part Number
-	-
-	-
24	1730-341-AE.S.
30	1730-341-AF.S.
36	1730-341-AB.S.
42	1730-341-R.S.
48	1730-341-S.S.
54	1730-341-T.S.
60	1730-341-U.S.
66	1730-341-W.S.
72	1730-341-AA.S.
78	1730-341-AR.S.



The following part numbers fit  
**6" diameter steel return/carrying rolls for 3613S, 3614S, 3617S, 3620S and 3626S idlers**

## C3600 Replacement Rolls

Belt Width	Part Number
18	1730-285-AE.S.
20	1730-285-AF.S.
24	1730-285-AG.S.
30	1730-285-AH.S.
36	1730-285-AJ.S.
42	1730-285-AK.S.
48	1730-285-AL.S.
-	-
-	-
-	-
-	-
-	-

## D3600 Replacement Rolls

Belt Width	Part Number
-	-
-	-
24	1730-342-AC.S.
30	1730-342-AJ.S.
36	1730-342-AB.S.
42	1730-342-R.S.
48	1730-342-S.S.
54	1730-342-T.S.
60	1730-342-U.S.
66	1730-342-W.S.
72	1730-342-AA.S.
78	1730-342-AK.S.

# Ordering Replacement Rolls

Below are the part numbers to reference when ordering sealed replacement rolls for CEMA Series C3000 and D3000. If regreasable rolls are required, drop the "S" suffix in the part number. Frame is not included.

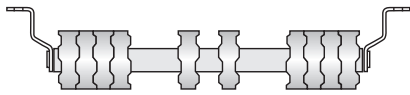

The following part numbers fit  
**5" diameter rubber tread return rolls for 3518S and 3521S idlers**

## C3500 Replacement Rolls

## D3500 Replacement Rolls

Belt Width	Part Number	Belt Width	Part Number
18	1730-524-B.S.	-	-
20	1730-524-C.S.	-	-
24	1730-524-D.S.	24	1730-523-X.S.
30	1730-524-E.S.	30	1730-523-V.S.
36	1730-524-F.S.	36	1730-523-U.S.
42	1730-524-G.S.	42	1730-523-E.S.
48	1730-524-H.S.	48	1730-523-F.S.
-	-	54	1730-523-G.S.
-	-	60	1730-523-H.S.
-	-	72	1730-523-J.S.

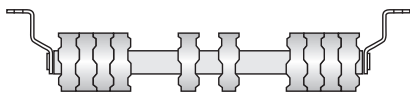

The following part numbers fit  
**6" diameter rubber tread return rolls for 3618S and 3621S idlers**

## C3600 Replacement Rolls

## D3600 Replacement Rolls

Belt Width	Part Number	Belt Width	Part Number
18	1730-229-B.S.	-	-
20	1730-229-C.S.	-	-
24	1730-229-D.S.	24	1730-358-X.S.
30	1730-229-E.S.	30	1730-358-V.S.
36	1730-229-F.S.	36	1730-358-U.S.
42	1730-229-G.S.	42	1730-358-E.S.
48	1730-229-H.S.	48	1730-358-F.S.
-	-	54	1730-358-G.S.
-	-	60	1730-358-H.S.
-	-	72	1730-358-J.S.

# Ordering Replacement Rolls

Below are the part numbers to reference when ordering sealed replacement rolls for CEMA Series C3000 and D3000. If regreasable rolls are required, drop the "S" suffix in the part number. Frame is not included.

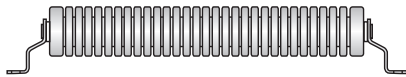

The following part numbers fit  
**5" diameter rubber cushion rolls for C3515S idlers**

## C3500 Replacement Rolls

Belt Width	Part Number
18	1730-328-A.S.
20	1730-328-B.S.
24	1730-328-C.S.
30	1730-328-D.S.
36	1730-328-E.S.
42	1730-328-F.S.
48	1730-328-G.S.

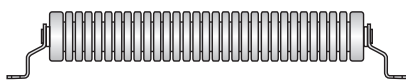

The following part numbers fit  
**6" diameter rubber cushion rolls for 3615S idlers**

## C3600 Replacement Rolls

Belt Width	Part Number
18	1730-325-A.S.
20	1730-325-B.S.
24	1730-325-C.S.
30	1730-325-D.S.
36	1730-325-E.S.
42	1730-325-F.S.
48	1730-325-G.S.
-	-
-	-
-	-

## D3600 Replacement Rolls

Belt Width	Part Number
-	-
-	-
24	1730-453-J.S.
30	1730-453-K.S.
36	1730-453-L.S.
42	1730-453-M.S.
48	1730-453-N.S.
54	1730-453-P.S.
60	1730-453-S.S.
72	1730-453-T.S.

# Introducing Composite Idler Rolls

- Combats roll degradation typically found in corrosive and abrasive environments
- Longer lasting rolls reduces conveyor downtime
- Lighter weight rolls – “Field Friendly” for maintenance and installation personnel
- Prolongs belt life by reducing material build-up



Dimensional specifications match our CEMA C, D and E series steel products.

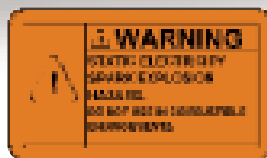

## Composite Idler Roll Advantages

- Excellent Strength
- Lighter Weight
- Superior Toughness
- High Corrosion Resistance
- High Abrasion Resistance
- Reduced Material Build-Up
- Low Coefficient of Thermal Expansion
- Environmentally Friendly



*Ideal for replacement of steel rolls in corrosive environments.*

# Composite Rolls

## Technical Data

---

### What are composite idler rolls?

- Syntron Material Handling introduces a revolutionary new idler roll made with state-of-the-art glass reinforced polyurethane.
- This tubing is a composite material consisting of layers of high quality glass fabric saturated with a two part thermoset polyurethane resin.
- Syntron Material Handling offers a 5" and a 6" diameter x 1/4" wall tubing size suitable for CEMA C, D and E roll applications (Syntron Material Handling C/D3500, C/D3600-- & E4600 Series).
- Roll lengths are available for troughing, return, picking and V-return idlers with belt widths ranging from 18" to 72".
- Polyurethane pultruded composite tubing offers excellent mechanical properties similar to steel and superior to many traditional plastic resin roll products. The recommended operating temperature range is -40°F to +200°F.
- Syntron Material Handling composite rolls are extremely versatile and are suitable for many material handling applications\*.
- Standard color: Traditional "Syntron Material Handling Orange"

\*Currently not suitable in combustible environments, where possible static charge can cause an explosion hazard.

### Features/Benefits

- **Excellent Strength**  
Comparable tensile and flexural strength (lengthwise) to steel and aluminum. High strength-to-weight ratio.
- **Lighter Weight**  
Material verses material: 75% lighter than steel and 30% lighter than aluminum. Approximately 50% lighter than traditional steel rolls. Easier installation, "Field Friendly" for maintenance and installation personnel, energy savings, and reduced noise.
- **Superior Toughness**  
This glass fabric distributes loads to prevent surface damage. No permanent deformities. High impact strength. Crack resistant.
- **High Corrosion Resistance**  
Superior resistance to a broad range of chemicals. Excellent in acid, alkali and salt spray environments. Low water absorption. Protective Polyurethane topcoat is suggested if exposed to UV rays during a long term storage.
- **High Abrasion Resistance**  
Superior wear resistance to traditional thermoplastic resin rolls, resulting in longer shell life, longer belt life, and less maintenance.
- **Reduced Material Build-Up**  
Polyurethane resin resists material build-up on the surface of the roll, thereby prolonging belt life.
- **Low Thermal Coefficient of Expansion**  
Low coefficient of thermal expansion, comparable to steel, reducing differential expansion between shell, shaft, and the pressed head.
- **Environmentally Friendly**  
Self extinguishing when exposed to flame in a horizontal position. Low carbon footprint compared to thermoplastic rolls. VOC Free.

### *Is corrosion eating away your profits?*



# Composite Rolls

Below are the part numbers to reference when ordering sealed replacement rolls for CEMA Series C3000 and D3000.

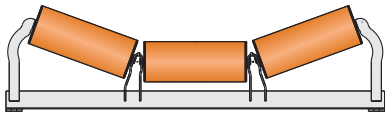

The following part numbers fit

**5”** diameter composite troughing rolls for 3601C, 3502C, 3506C, 3507C, 3508C, 3509C, 3511C, 3528C, 3532C and 3537C idlers

## C3500 Replacement Rolls

Belt Width	Part Number
18	5269-404-A
20	5269-404-B
24	5269-403-C
30	5269-403-D
36	5269-403-E
42	5269-403-F
48	5269-403-G
54	5269-403-H
60	5269-403-J
–	–

## D3500 Replacement Rolls

Belt Width	Part Number
–	–
–	–
24	5269-403-C
30	5269-403-D
36	5269-403-E
42	5269-403-F
48	5269-403-G
54	5269-403-H
60	5269-403-J
72	5269-403-L

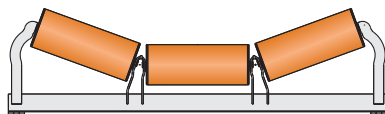

The following part numbers fit

**6”** diameter composite troughing rolls for 3601C, 3602C, 3606C, 3607C, 3608C, 3609C, 3611C, 3628C, 3632C and 3637C idlers

## C3600 Replacement Rolls

Belt Width	Part Number
18	5269-395-A
20	5269-395-B
24	5269-365-C
30	5269-365-D
36	5269-365-E
42	5269-365-F
48	5269-365-G
54	5269-365-H
60	5269-365-J
–	–

## D3600 Replacement Rolls

Belt Width	Part Number
–	–
–	–
24	5269-365-C
30	5269-365-D
36	5269-365-E
42	5269-365-F
48	5269-365-G
54	5269-365-H
60	5269-365-J
72	5269-365-L



# Composite Rolls

Below are the part numbers to reference when ordering sealed replacement rolls for CEMA Series C3000 and D3000.



The following part numbers fit

**5” diameter composite return/carrying rolls for 3513C, 3514C, 3517C, 3520C and 3526C idlers**

C3500 Replacement Rolls		D3500 Replacement Rolls	
Belt Width	Part Number	Belt Width	Part Number
18	5269-404-AA	-	-
20	5269-404-AB	-	-
24	5269-404-AC	24	5269-403-AC
30	5269-404-AD	30	5269-403-AD
36	5269-404-AE	36	5269-403-AE
42	5269-404-AF	42	5269-403-AF
48	5269-404-AG	48	5269-403-AG
-	-	54	5269-403-AH
-	-	60	5269-403-AJ
-	-	66	5269-403-AK
-	-	72	5269-403-AL
-	-	78	5269-403-AM



The following part numbers fit

**6” diameter composite return/carrying rolls for 3613C, 3614C, 3617C, 3620C and 3626C idlers**

C3600 Replacement Rolls		D3600 Replacement Rolls	
Belt Width	Part Number	Belt Width	Part Number
18	5269-395-AA	-	-
20	5269-395-AB	-	-
24	5269-395-AC	24	5269-365-AC
30	5269-395-AD	30	5269-365-AD
36	5269-395-AE	36	5269-365-AE
42	5269-395-AF	42	5269-365-AF
48	5269-395-AG	48	5269-365-AG
-	-	54	5269-365-AH
-	-	60	5269-365-AJ
-	-	66	5269-365-AK
-	-	72	5269-365-AL
-	-	78	5269-365-AM

# Side Guide Idlers

Side guide idlers are mounted at the edges of a conveyor belt to guide the belt and minimize belt edge wear. For smooth, trouble-free operation, these idlers are equipped with precision tapered roller bearings and grease seals.

## 20°

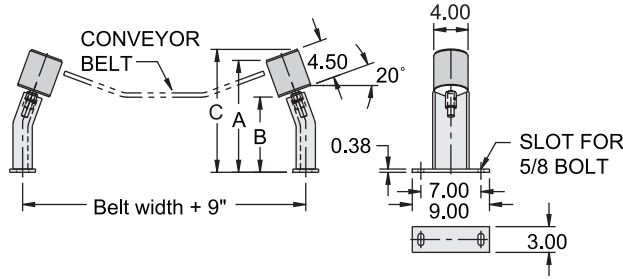

Belt width, inches	Idler number	Weight per pair, pounds	A	B	C
			Inches		
14	T2001	29	11.25	7.00	12.56
16	T2002	29	11.50	7.25	12.81
18	T2003	30	12.38	8.12	13.69
20	T2004	30	12.56	8.31	13.88
24	T2005	31	13.06	8.81	14.38
30	T2006	31	14.06	9.81	15.38
36	T2007	32	15.00	10.75	16.31
42	T2008	32	15.75	11.50	17.06
48	T2009	33	16.69	12.44	18.00
54	T2010	33	17.19	12.94	18.50
60	T2011	34	18.12	13.88	19.44
72	T2012	35	19.44	15.19	20.75

## 35°

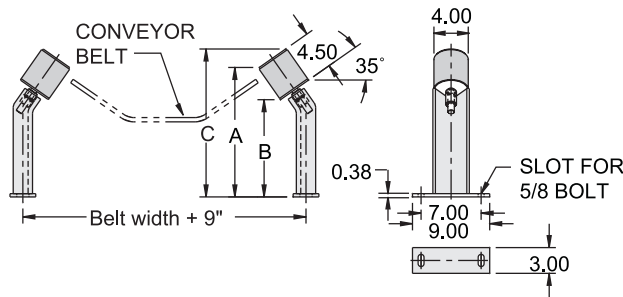

Belt width, inches	Idler number	Weight per pair, pounds	A	B	C
			Inches		
14	T3501	31	12.38	8.56	14.50
16	T3502	31	12.69	9.00	14.81
18	T3503	32	14.00	10.25	16.12
20	T3504	32	14.38	10.56	16.50
24	T3505	33	15.12	11.31	17.25
30	T3506	34	16.62	12.88	18.75
36	T3507	35	17.81	14.06	19.94
42	T3508	36	19.25	15.50	21.38
48	T3509	37	20.25	16.50	22.38
54	T3510	38	21.44	17.69	23.56
60	T3511	39	22.62	18.81	24.75
72	T3512	42	25.19	21.44	27.31

### Model Number F-1 for Flat Idlers

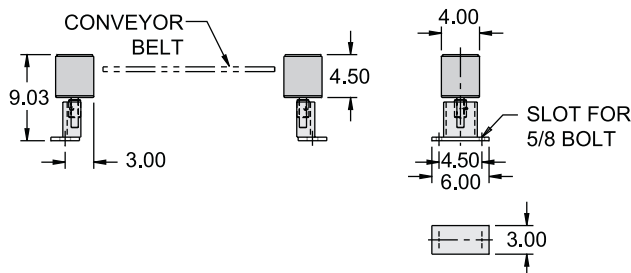

### Model Number R-1 for Return Idlers

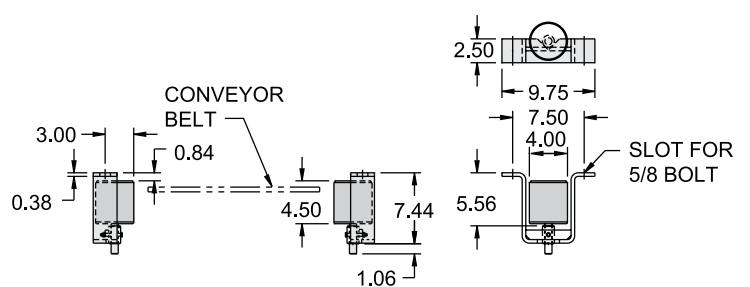

## Scale Idlers



Link-Belt scale idlers are used in conjunction with mechanical-type weighing devices. They are available in CEMA D and E series for 20°, 35° or 45° troughing installations. In order to prevent load shift and obtain weighing accuracy, these idlers are fabricated to rigid belt scale manufacturers specifications:

Roll run-out does not exceed .015" T.I.R.  
Footstraps are within 0.015" of flat surface.  
Axis of rolls is  $\pm 0.031$ " from perpendicular through center of base. Backing dimension of center roll is  $+ 0.000$ " -  $0.125$ ". End bracket is perpendicular to base  $90^\circ \pm 1^\circ$ . Troughing angle is template checked.

All rolls are factory lubricated and "sealed for life". For further specifications and dimensions, contact your nearest Syntron Material Handling Territory Manager.

When ordering scale quality idlers denote "W" in the Syntron Material Handling model number (example: D7628W-36).



# CEMA Series E4000 Idlers

## Bearings

- Precision tapered roller bearings with modified geometry; LM67000 with 1-1/4" bore
- Bearings/shaft are designed to accommodate bearing misalignment under fully rated loads
- L10 bearing life > 60,000 hrs @ 500 rpm, exceeds load ratings of 6308 ball bearing products

## Frames

- Inverted angle frame base with slotted foot straps to ensure quick, easy mounting and alignment
- Heavy-duty, die-formed, steel end brackets are contoured for generous clearance to safeguard against spilled materials becoming jammed and impeding the rotation of the rollers
- All idler frames are welded in accordance with AWS D1.1 specifications for structural welds

## Seal

- The outer adjusting nuts are zinc plated, machined steel, to minimize corrosion
- Rubber triple lip contact seal paired with a nylon deflector nut with integrated labyrinth seal for robust, redundant sealing capability
- Seal works well in dusty conditions and wash down environments

## Coatings

- Frames and rolls are powder-coated (see page 155 for details)
- Assembly hardware is electro-zinc plated

## CEMA

- Idlers meet or exceed CEMA requirements for rugged, continuous material handling
- Multiple belt widths and models available to meet your needs

## Roll Thickness

- 6" diameter = 8 ga (0.165) / 0.250" is available
- 7" diameter = 0.250"

## Testing Capabilities

- Load rating
- Seals
- Roll concentricity
- Roll resistance
- Roll imbalance
- Water resistance

One of the following letter suffixes may sometimes be necessary to complete an idler description:

**P** - Polyethylene rolls

**R** - Rubber lagged impact or rubber tread rolls

**RC** - Rubber lagged impact center roll

**W** - Scale idler

**U** - Urethane coated or lagged rolls

**GAL** - Galvanized frame

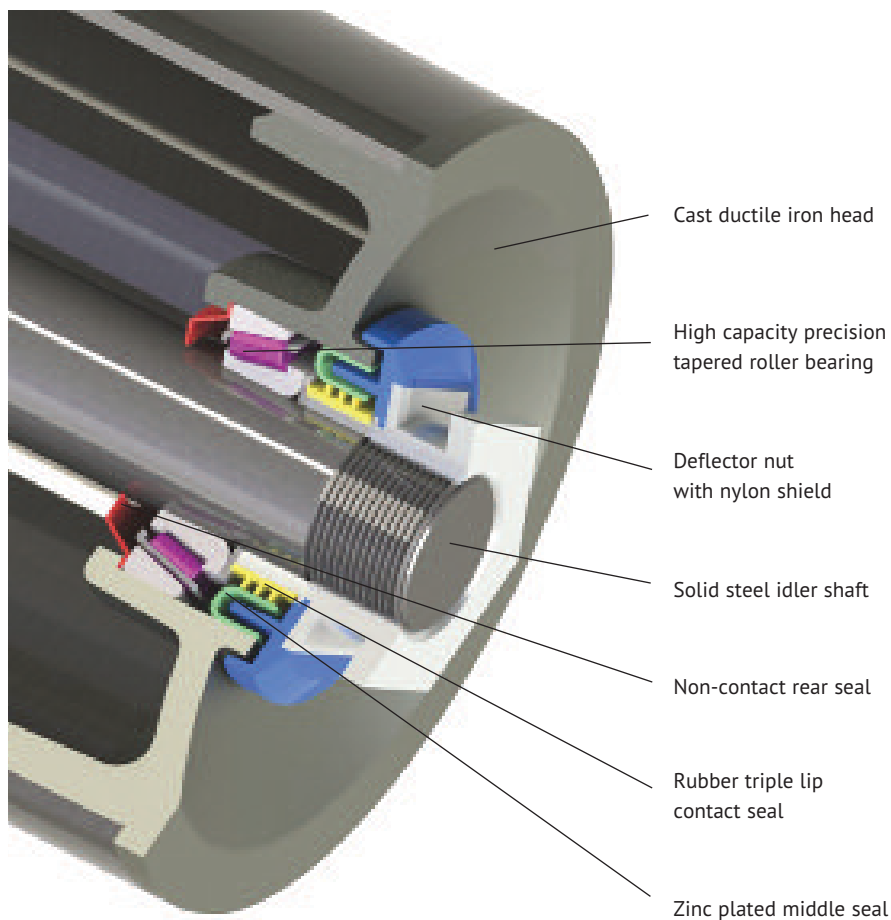

## Carrying Idler Types

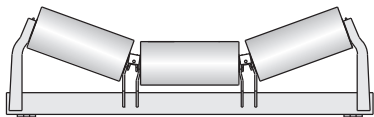

**Troughed belt idlers** for general carrying service are available with roll inclinations of 20°, 35°, and 45°.

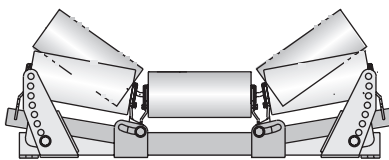

**Variable troughed belt idlers** placed between the final troughing idler and the head pulley, support the belt during its transition from a concave to a flat contour. The end rolls can be adjusted vertically to match the changing contour of the belt during this critical period of transition. Standard design features steel rolls. Also available with all rubber cushion rolls or rubber cushion center roll and steel end rolls.

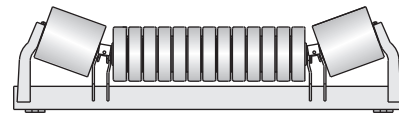

**Troughed belt picking and feeder conveyor idlers** carry the load in a wide, thin layer where picking and sorting are required or where a shallow bed of material is required to minimize degradation. Standard design features rubber cushion center roll and steel end rolls. Also available with all steel or all rubber cushion rolls.

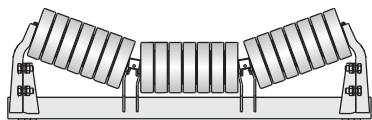

**Troughed belt rubber cushion idlers** protect the belt by absorbing impacts at loading and transfer points. Design features include removable end brackets on 35° and 45° idlers.

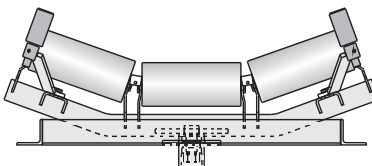

**Troughed belt training idlers** automatically train belts and protect belt edges from damage caused by misalignment. Positive action type for belts operating in one direction; actuating shoe type for two directional operation (reversing).



**Flat belt idlers** are used for handling bulk materials such as prepared foundry sand and undelinted cotton seed where it is desirable to plow off material at one or more intermediate points along the conveyor. Also used for pulpwood logs, packages, picking and sorting conveyors.



**Flat belt rubber cushion idlers** protect the belt by absorbing impacts at loading and transfer points. Fixed shaft type is for average service.

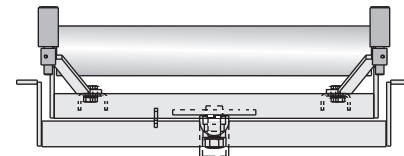

**Flat belt training idlers** automatically train belts and protect belt edges from damage caused by misalignment. Available in the positive action type for belts operating in one direction.

## Return Idler Types



**Return belt idlers** carry the empty belt on the return run. Available with a urethane coating on standard steel rollers.

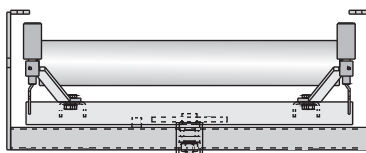

**Return belt training idlers** train the belt and protect its edges from damage caused by misalignment. Positive action type for belts operating in one direction. Actuating shoe type for reversing belts.

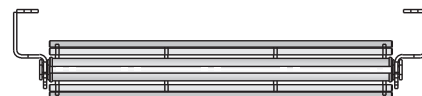

**Return belt beater idlers** remove excessive amounts of tenacious materials that adhere to the belt.

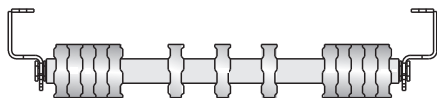

**Return belt rubber tread idlers** are used when wet or sticky materials tend to cling to the belt, where corrosion resistance is required or where chemical reaction to iron or steel is involved. Available with urethane treads.

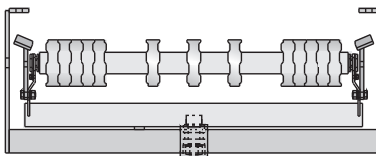

**Return rubber tread training idlers** train the belt and protect its edges from damage caused by misalignment. Used when wet or sticky materials tend to cling to the belt, where corrosion resistance is required or where chemical attraction to iron or steel is involved. Positive action type for belts operating in one direction. Actuating shoe type for reversing belts.

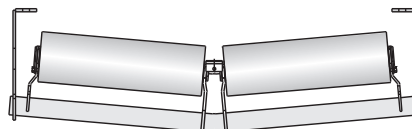

**Rigid frame v-return idlers** provide a means of training the return belt, with the added benefit of additional carrying load capacity. Rigid v-returns can be adjusted using slotted bolt holes in the end brackets of the frame to aid in proper belt training.

## CEMA E idlers of every type to meet your specific needs...

Syntron Material Handling Model Number	Page	CEMA E	5°	10°	15°	20°	35°	45°	10-35° Variable
4601S / 4701S	100	36" - 96"				●			
4602S / 4702S	108	36" - 96"						●	
4604S / 4704S	101	36" - 96"				●			
4605S / 4705S	110	36" - 72"				●			
4605RCS / 4705RCS	111	36" - 72"				●			
4606S / 4706S	112	36" - 96"							●
4607S / 4707S	102	36" - 72"				●			
4608S / 4708S	103	36" - 72"				●			
4613S / 4713S	113	36" - 96"							
4613LS / 4713LS	114	36" - 96"							
4614S / 4714S	117	36" - 72"							
4615S / 4715S	116	36" - 96"							
4716S	115	36" - 96"							
4617S / 4717S	119	36" - 96"							
4618S / 4718S	120	36" - 96"							
4619S / 4719S	118	36" - 96"							
4620S / 4720S	121	36" - 72"							
4621S / 4721S	122	36" - 72"							
4623S / 4723S	109	36" - 96"						●	
4626S / 4726S	123	36" - 72"							
4627S / 4727S	124	36" - 72"							
4628S / 4728S	104	36" - 96"					●		
4630S / 4730S	105	36" - 96"					●		
4632S / 4732S	106	36" - 72"					●		
4637S / 4737S	107	36" - 72"					●		
4664S / 4764S	125	36" - 102"	●						
4665S / 4765S	126	36" - 102"		●					
4666S / 4766S	127	36" - 102"			●				
4668S / 4768S	128	36" - 102"		●					



CAUTION: Link-Belt Conveyor Idlers must be installed, operated and maintained in accordance with Syntron Material Handling Service Instructions. Failure to follow these instructions can result in serious personal injury, property damage or both.

Syntron Material Handling Service Instructions are available for download at [www.syntronmh.com](http://www.syntronmh.com).

Flat Carrying	Return	V Return	Training Positive	Training Reversing	Picking & Feeding	Live Shaft	Steel	Rubber Cushion (Impact)	Rubber Tread
							●		
							●		
								●	
					●		●		
					●			●	
							●		
			●				●		
				●			●		
●							●		
●						●	●		
●			●				●		
●								●	
●						●		●	
	●						●		
	●								●
	●						●		
	●		●				●		
	●		●						●
								●	
	●			●			●		
	●			●					●
							●		
								●	
			●				●		
				●			●		
		●					●		
		●					●		
		●					●		
		●							●

# 20° Troughed Belt Idlers, Equal Length Rolls

steel rolls

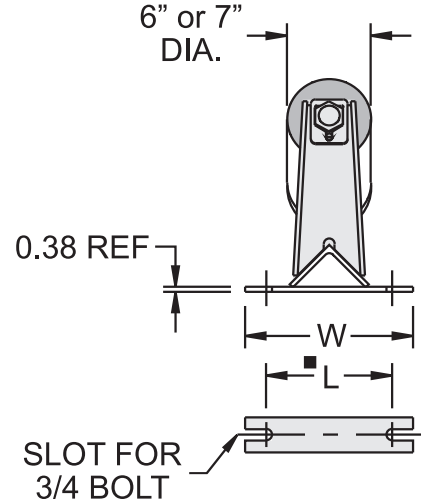
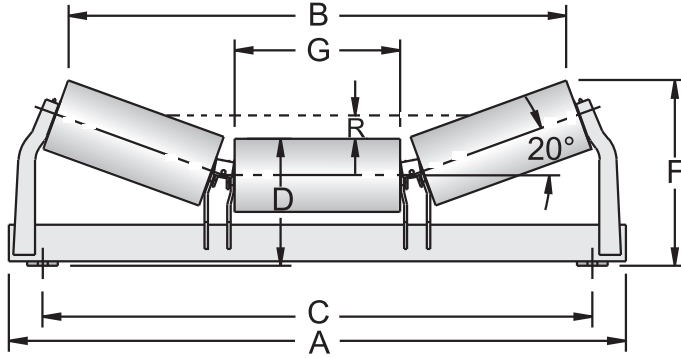

## CEMA E

Belt width, inches	Dia.	Idler number	Standard Base (Belt width + 9")			Wide Base (Belt width + 15")			B	D	F	G	L	R**	W
			Idler weight, pounds	A	C	Idler weight, pounds	A	C							
36	6"	E4601S-36	143	50.50	45.00	145	53.50	51.00	40.81	10.44	15.25	13.56	9.00	1.88	12.00
	7"	E4701S-36	172	50.50	45.00	174	53.50	51.00	40.50	10.94	15.69	13.56	9.00	1.88	12.00
42	6"	E4601S-42	160	56.00	51.00	162	59.50	57.00	46.56	10.44	15.94	15.56	9.00	2.19	12.00
	7"	E4701S-42	193	56.00	51.00	195	59.50	57.00	46.25	10.94	16.38	15.56	9.00	2.19	12.00
48	6"	E4601S-48	173	62.00	57.00	175	65.50	63.00	52.31	10.44	16.62	17.56	9.00	2.56	12.00
	7"	E4701S-48	211	62.00	57.00	214	65.50	63.00	52.00	10.94	17.06	17.56	9.00	2.56	12.00
54	6"	E4601S-54	190	68.00	63.00	192	71.50	69.00	58.25	10.44	17.31	19.62	9.00	2.88	12.00
	7"	E4701S-54	231	68.00	63.00	233	71.50	69.00	57.88	10.94	17.75	19.62	9.00	2.88	12.00
60	6"	E4601S-60	204	74.00	69.00	206	77.50	75.00	63.31	10.44	17.94	21.38	9.00	3.25	12.00
	7"	E4701S-60	247	74.00	69.00	249	77.50	75.00	63.00	10.94	18.38	21.38	9.00	3.25	12.00
72	6"	E4601S-72	248	86.00	81.00	251	89.50	87.00	74.50	11.12	19.94	25.25	9.00	3.94	12.00
	7"	E4701S-72	299	86.00	81.00	302	89.50	87.00	74.12	11.62	20.38	25.25	9.00	3.94	12.00
84	6"	E4601S-84	323	98.00	93.00	327	101.50	99.00	86.00	11.88	22.06	29.25	11.50	4.62	14.50
	7"	E4701S-84	379	98.00	93.00	383	101.50	99.00	85.62	12.38	22.50	29.25	11.50	4.62	14.50
96	6"	E4601S-96	360	110.00	105.00	364	113.50	111.00	97.50	11.88	23.44	33.25	11.50	5.31	14.50
	7"	E4701S-96	424	110.00	105.00	428	113.50	111.00	97.12	12.38	23.88	33.25	11.50	5.31	14.50

\*\* To top of discharge or bend pulleys, except foot pulley.

■ 10" bolt spacing recommended to permit washer clearance and adjustment.



# 20° Troughed Belt Idlers, Equal Length Rolls

rubber cushion rolls (impact)

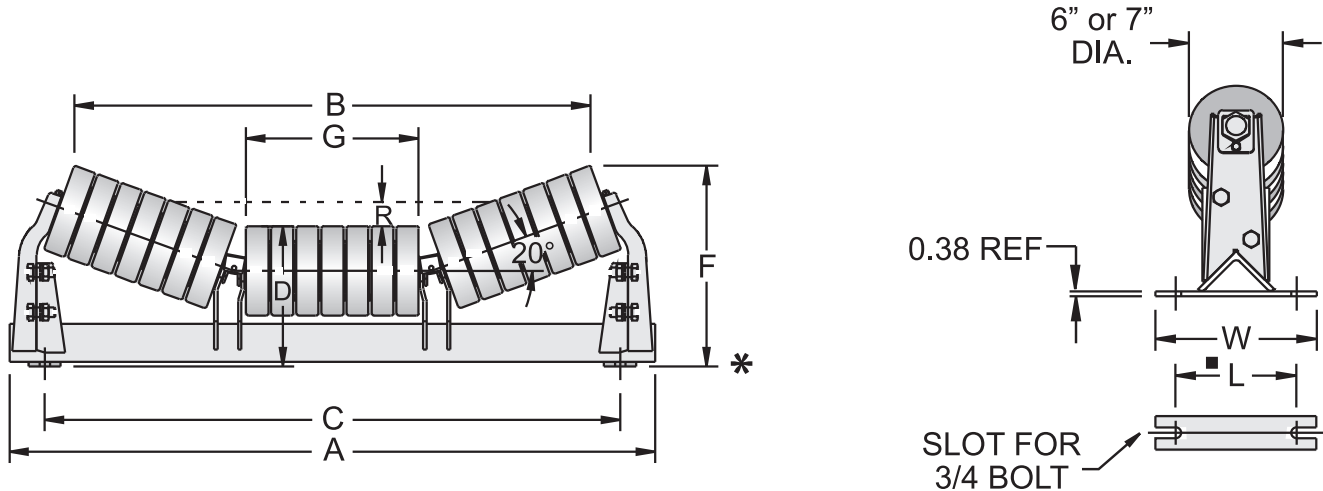

\* Demountable end bracket supplied for 36"- 96" belt widths

## CEMA E

Belt width, inches	Dia.	Idler number	Standard Base (Belt width + 9")		Wide Base (Belt width + 15")		B	D	F	G	L	R**	W		
			Idler weight, pounds	A	C	Idler weight, pounds								A	C
36	6"	E4604S-36	145	50.50	45.00	148	53.50	51.00	40.69	10.44	15.25	13.50	9.00	1.88	12.00
	7"	E4704S-36	161	50.50	45.00	163	53.50	51.00	40.38	10.94	15.69	13.50	9.00	1.88	12.00
42	6"	E4604S-42	165	56.00	51.00	168	59.50	57.00	46.44	10.44	15.94	15.50	9.00	2.19	12.00
	7"	E4704S-42	183	56.00	51.00	186	59.50	57.00	46.12	10.94	16.38	15.50	9.00	2.19	12.00
48	6"	E4604S-48	182	62.00	57.00	185	65.50	63.00	52.25	10.44	16.62	17.50	9.00	2.56	12.00
	7"	E4704S-48	202	62.00	57.00	205	65.50	63.00	51.88	10.94	17.06	17.50	9.00	2.56	12.00
54	6"	E4604S-54	199	68.00	63.00	202	71.50	69.00	58.12	10.44	17.31	19.56	9.00	2.88	12.00
	7"	E4704S-54	222	68.00	63.00	224	71.50	69.00	57.81	10.94	17.75	19.56	9.00	2.88	12.00
60	6"	E4604S-60	214	74.00	69.00	217	77.50	75.00	63.19	10.44	17.88	21.31	9.00	3.25	12.00
	7"	E4704S-60	239	74.00	69.00	242	77.50	75.00	62.88	10.94	18.38	21.31	9.00	3.25	12.00
72	6"	E4604S-72	265	86.00	81.00	268	89.50	87.00	74.38	11.19	19.94	25.19	9.00	3.94	12.00
	7"	E4704S-72	294	86.00	81.00	297	89.50	87.00	74.00	11.69	20.44	25.19	9.00	3.94	12.00
84	6"	E4604S-84	364	98.00	93.00	369	101.50	99.00	85.88	11.94	22.06	29.19	11.50	4.62	14.50
	7"	E4704S-84	397	98.00	93.00	403	101.50	99.00	85.56	12.44	22.50	29.19	11.50	4.62	14.50
96	6"	E4604S-96	407	110.00	105.00	412	113.50	111.00	97.38	11.94	23.44	33.19	11.50	5.31	14.50
	7"	E4704S-96	444	110.00	105.00	450	113.50	111.00	97.06	12.44	23.88	33.19	11.50	5.31	14.50

\*\* To top of discharge or bend pulleys, except foot pulley.

■ 10" bolt spacing recommended to permit washer clearance and adjustment.  
(12.5" for 84" and 96" belt widths.)

# 20° Troughed Belt Training Idlers, Equal Length Rolls

**positive action type**  
(above deck mounting)

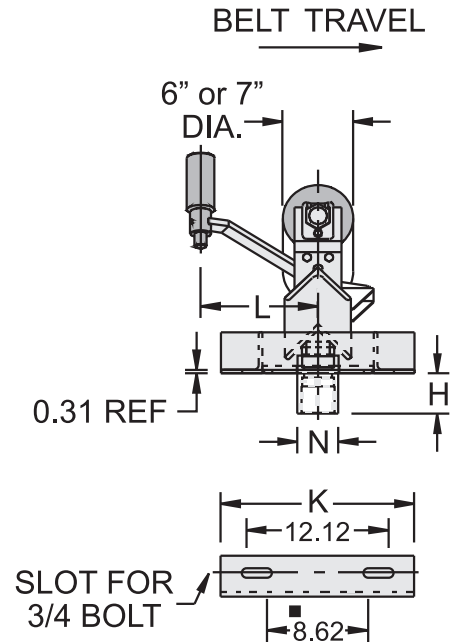
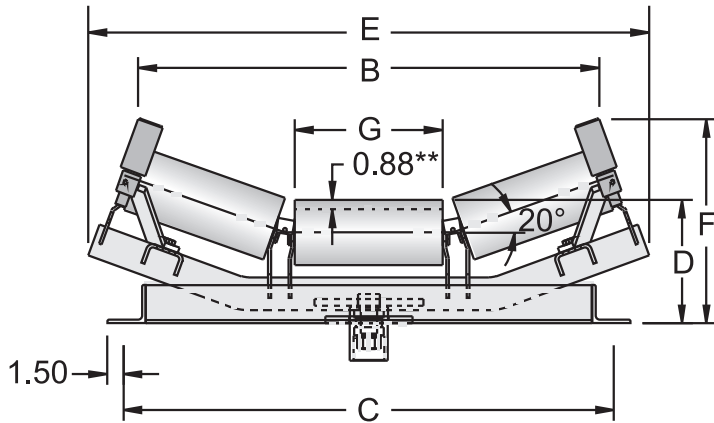

## CEMA E

Belt width, inches	Dia.	Idler number	Standard Base (Belt width + 9")		Wide Base (Belt width + 15")		B	D	E	F	G	H	K	L	N
			Idler weight, pounds	C	Idler weight, pounds	C									
36	6"	E4607S-36	268	45.00	271	51.00	42.31	11.31	51.25	18.69	13.56	3.69	16.50	10.00	3.50
	7"	E4707S-36	300	45.00	303	51.00	42.31	11.81	51.25	18.69	13.56	3.69	16.50	10.00	3.50
42	6"	E4607S-42	296	51.00	300	57.00	48.06	11.31	57.00	19.38	15.56	3.69	16.50	10.00	3.50
	7"	E4707S-42	330	51.00	334	57.00	48.06	11.81	57.00	19.38	15.56	3.69	16.50	10.00	3.50
48	6"	E4607S-48	323	57.00	327	63.00	53.81	11.31	62.75	20.06	17.56	3.69	16.50	10.00	3.50
	7"	E4707S-48	362	57.00	366	63.00	53.81	11.81	62.75	20.06	17.56	3.69	16.50	10.00	3.50
54	6"	E4607S-54	353	63.00	357	69.00	59.62	11.31	68.69	20.75	19.62	3.69	16.50	10.00	3.50
	7"	E4707S-54	394	63.00	398	69.00	59.62	11.81	68.69	20.75	19.62	3.69	16.50	10.00	3.50
60	6"	E4607S-60	379	69.00	382	75.00	64.69	11.31	73.75	21.31	21.38	3.69	16.50	10.00	3.50
	7"	E4707S-60	422	69.00	425	75.00	64.69	11.81	73.75	21.31	21.38	3.69	16.50	10.00	3.50
72	6"	E4607S-72	523	81.00	528	87.00	75.88	12.00	85.44	23.31	25.25	4.75	21.50	15.00	5.25
	7"	E4707S-72	574	81.00	579	87.00	75.88	12.50	85.44	23.31	25.25	4.75	21.50	15.00	5.25

\*\* To top of discharge or bend pulleys, except foot pulley.

■ 10" bolt spacing recommended to permit adjustment.

.165 wall rolls are standard for E-6"; .25 is available.

.25 wall rolls are standard for E-7".

# 20° Troughed Belt Idlers, Equal Length Rolls

actuating shoe type  
(above deck mounting)

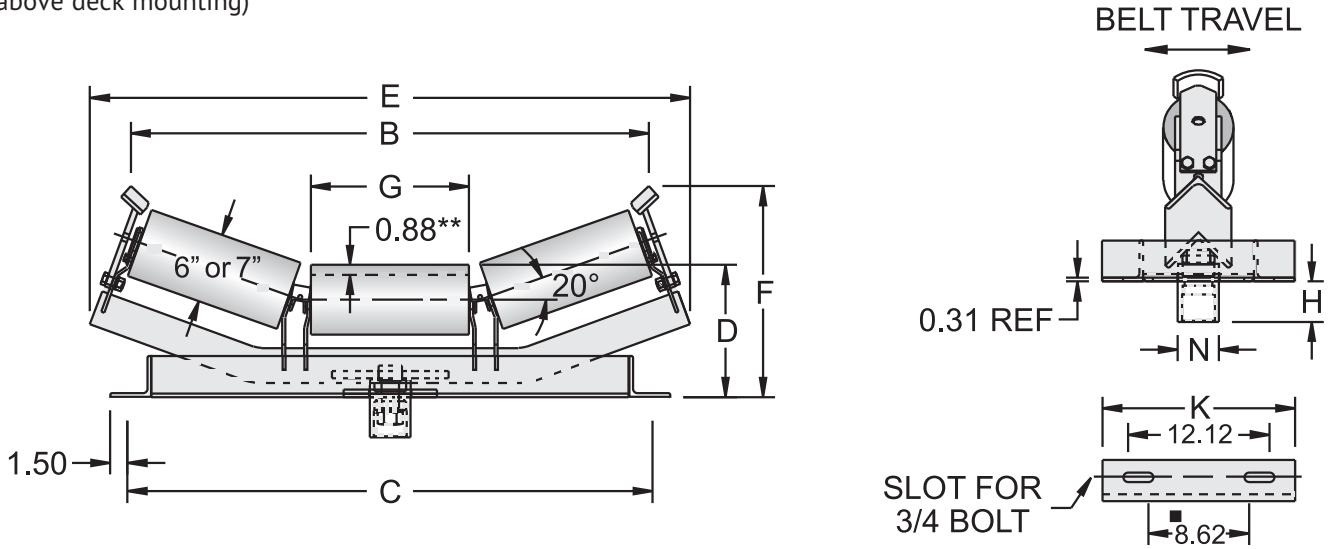

## CEMA E

Belt width, inches	Dia.	Idler number	Standard Base (Belt width + 9")		Wide Base (Belt width + 15")		B	D	E	F	G	H	K	N
			Idler weight, pounds	C	Idler weight, pounds	C								
36	6"	E4608S-36	244	45.00	247	51.00	44.69	11.31	51.25	17.69	13.56	3.69	16.50	3.50
	7"	E4708S-36	274	45.00	278	51.00	44.31	11.81	51.25	18.19	13.56	3.69	16.50	3.50
42	6"	E4608S-42	269	51.00	273	57.00	50.44	11.31	57.00	18.38	15.56	3.69	16.50	3.50
	7"	E4708S-42	303	51.00	307	57.00	50.12	11.81	57.00	18.81	15.56	3.69	16.50	3.50
48	6"	E4608S-48	292	57.00	296	63.00	56.25	11.31	62.75	19.06	17.56	3.69	16.50	3.50
	7"	E4708S-48	332	57.00	335	63.00	55.88	11.81	62.75	19.50	17.56	3.69	16.50	3.50
54	6"	E4608S-54	319	63.00	323	69.00	62.19	11.31	68.69	19.75	19.62	3.69	16.50	3.50
	7"	E4708S-54	361	63.00	364	69.00	61.81	11.81	68.69	20.25	19.62	3.69	16.50	3.50
60	6"	E4608S-60	343	69.00	346	75.00	67.19	11.31	73.75	20.38	21.38	3.69	16.50	3.50
	7"	E4708S-60	385	69.00	389	75.00	66.88	11.81	73.75	20.88	21.38	3.69	16.50	3.50
72	6"	E4608S-72	481	81.00	486	87.00	78.31	12.00	85.44	22.38	25.25	4.75	21.50	5.25
	7"	E4708S-72	533	81.00	538	87.00	78.00	12.50	85.44	22.88	25.25	4.75	21.50	5.25

\*\* Elevation above adjacent idlers.

■ 10" bolt spacing recommended to permit adjustment.

# 35° Troughed Belt Idlers, Equal Length Rolls

steel rolls

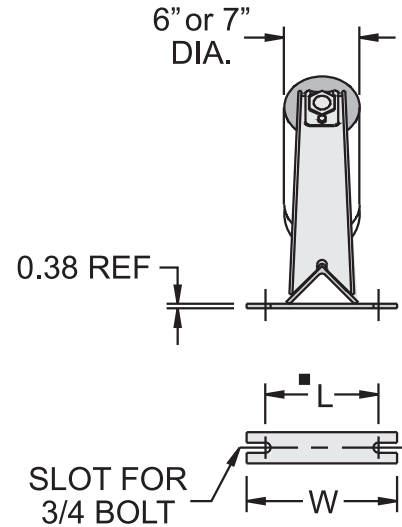
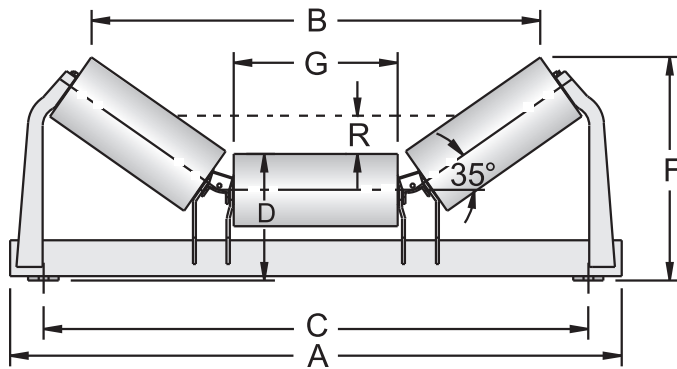

## CEMA E

Belt width, inches	Dia.	Idler number	Standard Base (Belt width + 9")			Wide Base (Belt width + 15")			B	D	F	G	L	R**	W
			Idler weight, pounds	A	C	Idler weight, pounds	A	C							
36	6"	E4628S-36	149	50.50	45.00	151	53.50	51.00	37.06	10.44	18.44	13.56	9.00	3.12	12.00
	7"	E4728S-36	179	50.50	45.00	181	53.50	51.00	36.50	10.94	18.88	13.56	9.00	3.12	12.00
42	6"	E4628S-42	168	56.00	51.00	170	59.50	57.00	42.38	10.44	19.56	15.56	9.00	3.69	12.00
	7"	E4728S-42	199	56.00	51.00	201	59.50	57.00	41.75	10.94	20.00	15.56	9.00	3.69	12.00
48	6"	E4628S-48	181	62.00	57.00	184	65.50	63.00	47.62	10.44	20.75	17.56	9.00	4.31	12.00
	7"	E4728S-48	217	62.00	57.00	220	65.50	63.00	47.06	10.94	21.12	17.56	9.00	4.31	12.00
54	6"	E4628S-54	199	67.00	63.00	202	71.50	69.00	53.06	10.44	21.94	19.62	9.00	4.88	12.00
	7"	E4728S-54	241	67.00	63.00	244	71.50	69.00	52.50	10.94	22.31	19.62	9.00	4.88	12.00
60	6"	E4628S-60	213	71.75	69.00	217	77.50	75.00	57.75	10.44	22.94	21.38	9.00	5.44	12.00
	7"	E4728S-60	257	71.75	69.00	261	77.50	75.00	57.12	10.94	23.31	21.38	9.00	5.44	12.00
72	6"	E4628S-72	260	83.50	81.00	265	89.50	87.00	67.94	11.12	25.81	25.25	9.00	6.62	12.00
	7"	E4728S-72	310	83.50	81.00	315	89.50	87.00	67.38	11.62	26.25	25.25	9.00	6.62	12.00
84	6"	E4628S-84	337	95.50	93.00	344	101.50	99.00	78.44	11.88	28.88	29.25	11.50	7.81	14.50
	7"	E4728S-84	392	95.50	93.00	399	101.50	99.00	77.88	12.38	29.31	29.25	11.50	7.81	14.50
96	6"	E4628S-96	378	107.50	105.00	385	113.50	111.00	89.00	11.88	31.19	33.25	11.50	8.94	14.50
	7"	E4728S-96	439	107.50	105.00	446	113.50	111.00	88.44	12.38	31.56	33.25	11.50	8.94	14.50

\*\* To top of discharge or bend pulleys, except foot pulley.

■ 10" bolt spacing recommended to permit washer clearance and adjustment.  
(12.5" for 84" and 96" belt widths.)

# 35° Troughed Belt Idlers, Equal Length Rolls

rubber cushion rolls (impact)

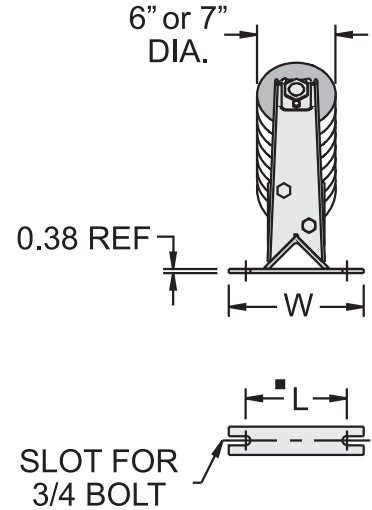
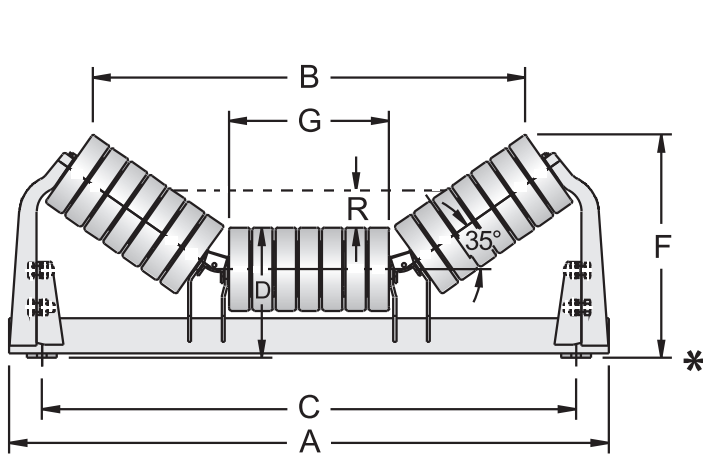

\* Demountable end bracket supplied for 36"- 96" belt widths

## CEMA E

Belt width, inches	Dia.	Idler number	Standard Base (Belt width + 9")		Wide Base (Belt width + 15")		B	D	F	G	L	R**	W		
			Idler weight, pounds	A	C	Idler weight, pounds								A	C
36	6"	E4630S-36	160	50.50	45.00	163	53.50	51.00	37.00	10.44	18.44	13.50	9.00	3.12	12.00
	7"	E4730S-36	176	50.50	45.00	178	53.50	51.00	36.44	10.94	18.81	13.50	9.00	3.12	12.00
42	6"	E4630S-42	181	56.00	51.00	184	59.50	57.00	42.31	10.44	19.56	15.50	9.00	3.75	12.00
	7"	E4730S-42	199	56.00	51.00	202	59.50	57.00	41.69	10.94	20.00	15.50	9.00	3.75	12.00
48	6"	E4630S-48	199	62.00	57.00	203	65.50	63.00	47.56	10.44	20.75	17.50	9.00	4.31	12.00
	7"	E4730S-48	219	62.00	57.00	223	65.50	63.00	47.00	10.94	21.12	17.50	9.00	4.31	12.00
54	6"	E4630S-54	217	67.00	63.00	221	71.50	69.00	53.00	10.44	21.88	19.56	9.00	4.88	12.00
	7"	E4730S-54	240	67.00	63.00	243	71.50	69.00	52.44	10.94	22.31	19.56	9.00	4.88	12.00
60	6"	E4630S-60	233	71.75	69.00	238	77.50	75.00	57.62	10.44	22.88	21.31	9.00	5.44	12.00
	7"	E4730S-60	258	71.75	69.00	262	77.50	75.00	57.06	10.94	23.31	21.31	9.00	5.44	12.00
72	6"	E4630S-72	285	83.50	81.00	291	89.50	87.00	67.88	11.19	25.81	25.19	9.00	6.62	12.00
	7"	E4730S-72	314	83.50	81.00	320	89.50	87.00	67.31	11.69	26.25	25.19	9.00	6.62	12.00
84	6"	E4630S-84	376	95.50	93.00	385	101.50	99.00	78.44	11.94	28.88	29.19	11.50	7.75	14.50
	7"	E4730S-84	409	95.50	93.00	419	101.50	99.00	77.81	12.44	29.31	29.19	11.50	7.75	14.50
96	6"	E4630S-96	421	107.50	105.00	430	113.50	111.00	88.94	11.94	31.19	33.19	11.50	8.94	14.50
	7"	E4730S-96	458	107.50	105.00	468	113.50	111.00	88.38	12.44	31.56	33.19	11.50	8.94	14.50

\*\* To top of discharge or bend pulleys, except foot pulley.

■ 10" bolt spacing recommended to permit washer clearance and adjustment.  
(12.5" for 84" and 96" belt widths.)

# 35°

## Troughed Belt Training Idlers, Equal Length Rolls

**positive action type**

(above deck mounting)

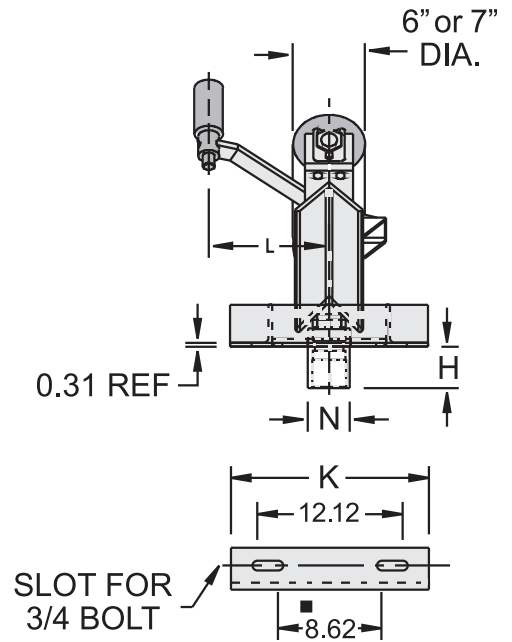
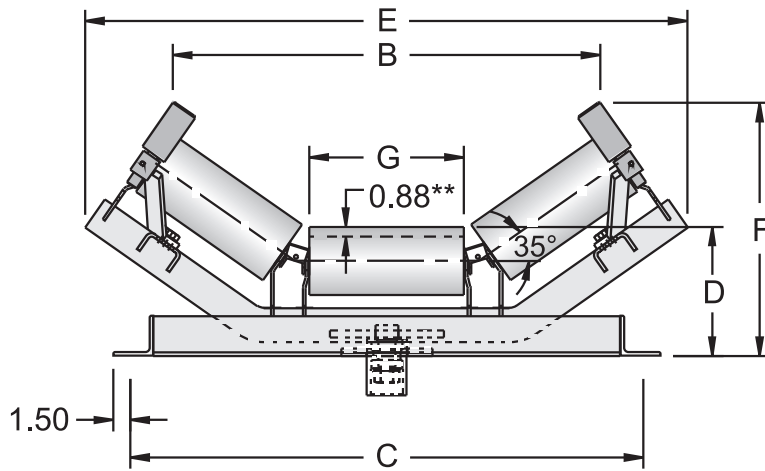

## CEMA E

Belt width, inches	Dia.	Idler number	Standard Base (Belt width + 9")		Wide Base (Belt width + 15")		B	D	E	F	G	H	K	L	N
			Idler weight, pounds	C	Idler weight, pounds	C									
36	6"	E4632S-36	261	45.00	264	51.00	37.62	11.31	52.25	22.12	13.56	3.69	16.50	10.00	3.50
	7"	E4732S-36	291	45.00	295	51.00	37.62	11.81	52.25	22.12	13.56	3.69	16.50	10.00	3.50
42	6"	E4632S-42	287	51.00	291	57.00	42.94	11.31	57.50	23.25	15.56	3.69	16.50	10.00	3.50
	7"	E4732S-42	320	51.00	324	57.00	42.94	11.81	57.50	23.25	15.56	3.69	16.50	10.00	3.50
48	6"	E4632S-48	310	57.00	314	63.00	48.06	11.31	62.81	24.38	17.56	3.69	16.50	10.00	3.50
	7"	E4732S-48	349	57.00	352	63.00	48.06	11.81	62.81	24.38	17.56	3.69	16.50	10.00	3.50
54	6"	E4632S-54	337	63.00	341	69.00	53.50	11.31	68.25	25.56	19.62	3.69	16.50	10.00	3.50
	7"	E4732S-54	379	63.00	382	69.00	53.50	11.81	68.25	25.56	19.62	3.69	16.50	10.00	3.50
60	6"	E4632S-60	356	69.00	359	75.00	58.19	11.31	72.88	26.56	21.38	3.69	16.50	10.00	3.50
	7"	E4732S-60	399	69.00	403	75.00	58.19	11.81	72.88	26.56	21.38	3.69	16.50	10.00	3.50
72	6"	E4632S-72	495	81.00	500	87.00	68.38	12.00	83.88	29.44	25.25	4.75	21.50	15.00	5.25
	7"	E4732S-72	546	81.00	551	87.00	68.38	12.50	83.88	29.44	25.25	4.75	21.50	15.00	5.25

\*\* Elevation above adjacent idlers.

■ 10" bolt spacing recommended to permit adjustment.

# 35°

## Troughed Belt Training Idlers, Equal Length Rolls

### actuating shoe type

(above deck mounting)

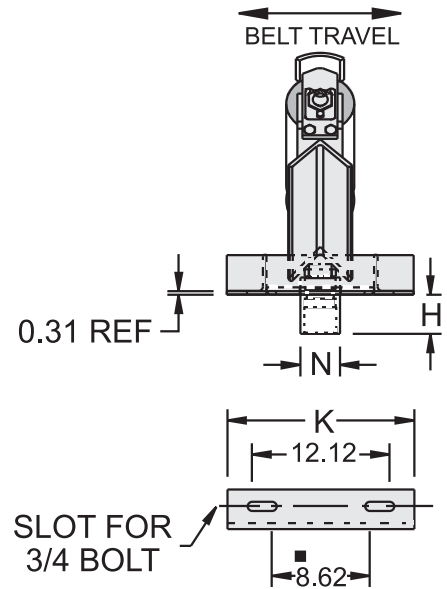
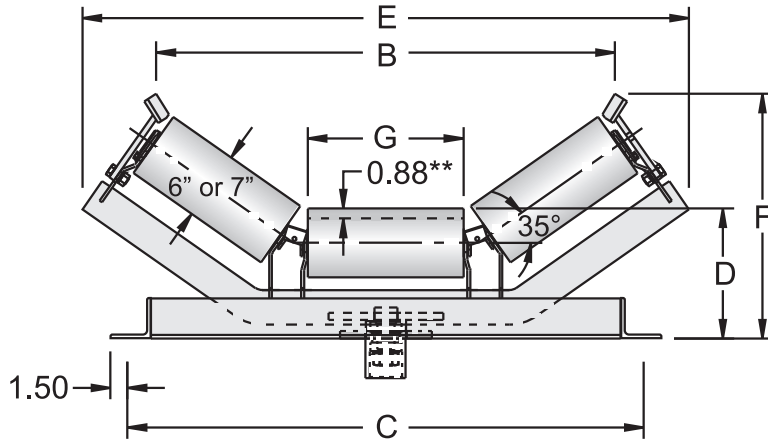

## CEMA E

Belt width, inches	Dia.	Idler number	Standard Base (Belt width + 9")		Wide Base (Belt width + 15")		B	D	E	F	G	H	K	N
			Idler weight, pounds	C	Idler weight, pounds	C								
Inches														
36	6"	E4637S-36	248	45.00	251	51.00	40.00	11.31	52.25	21.31	13.56	3.69	16.50	3.50
	7"	E4737S-36	278	45.00	282	51.00	39.44	11.81	52.25	21.75	13.56	3.69	16.50	3.50
42	6"	E4637S-42	273	51.00	277	57.00	45.25	11.31	57.50	22.44	15.56	3.69	16.50	3.50
	7"	E4737S-42	307	51.00	311	57.00	44.69	11.81	57.50	22.88	15.56	3.69	16.50	3.50
48	6"	E4637S-48	297	57.00	301	63.00	50.56	11.31	62.81	23.62	17.56	3.69	16.50	3.50
	7"	E4737S-48	336	57.00	339	63.00	49.94	11.81	62.81	24.00	17.56	3.69	16.50	3.50
54	6"	E4637S-54	324	63.00	328	69.00	56.00	11.31	68.25	24.81	19.62	3.69	16.50	3.50
	7"	E4737S-54	365	63.00	368	69.00	55.38	11.81	68.25	25.19	19.62	3.69	16.50	3.50
60	6"	E4637S-60	343	69.00	346	75.00	60.62	11.31	72.88	25.81	21.38	3.69	16.50	3.50
	7"	E4737S-60	385	69.00	389	75.00	60.06	11.81	72.88	26.19	21.38	3.69	16.50	3.50
72	6"	E4637S-72	481	81.00	486	87.00	70.81	12.00	83.88	28.69	25.25	4.75	21.50	5.25
	7"	E4737S-72	533	81.00	538	87.00	70.25	12.50	83.88	29.12	25.25	4.75	21.50	5.25

\*\* Elevation above adjacent idlers.

■ 10" bolt spacing recommended to permit adjustment.



# 45° Troughed Belt Idlers, Equal Length Rolls

steel rolls

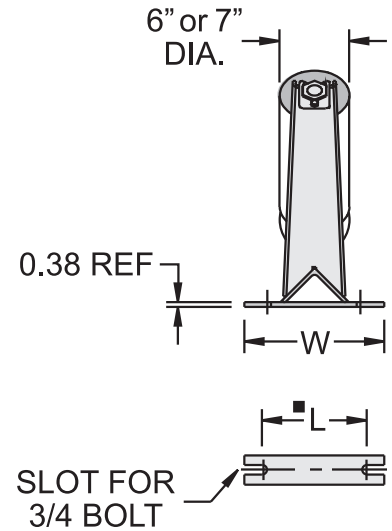
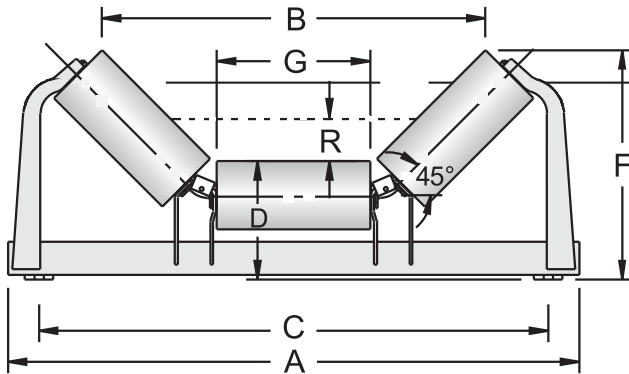

## CEMA E

Belt width, inches	Dia.	Idler number	Standard Base (Belt width + 9")			Wide Base (Belt width + 15")			B	D	F	G	L	R**	W
			Idler weight, pounds	A	C	Idler weight, pounds	A	C							
36	6"	E4602S-36	151	50.50	45.00	153	53.50	51.00	33.88	10.44	20.25	13.56	9.00	3.88	12.00
	7"	E4702S-36	181	50.50	45.00	183	53.50	51.00	33.19	10.94	20.62	13.56	9.00	3.88	12.00
42	6"	E4602S-42	171	56.00	51.00	173	59.50	57.00	38.62	10.44	21.69	15.56	9.00	4.62	12.00
	7"	E4702S-42	202	56.00	51.00	204	59.50	57.00	37.88	10.94	22.00	15.56	9.00	4.62	12.00
48	6"	E4602S-48	184	62.00	57.00	186	65.50	63.00	43.44	10.44	23.06	17.56	9.00	5.31	12.00
	7"	E4702S-48	223	62.00	57.00	225	65.50	63.00	42.75	10.94	23.44	17.56	9.00	5.31	12.00
54	6"	E4602S-54	201	65.50	63.00	205	71.50	69.00	48.50	10.44	24.50	19.62	9.00	6.00	12.00
	7"	E4702S-54	243	65.50	63.00	247	71.50	69.00	47.75	10.94	24.88	19.62	9.00	6.00	12.00
60	6"	E4602S-60	218	71.50	69.00	222	77.50	75.00	52.69	10.44	25.75	21.38	9.00	6.75	12.00
	7"	E4702S-60	262	71.50	69.00	266	77.50	75.00	52.00	10.94	26.12	21.38	9.00	6.75	12.00
72	6"	E4602S-72	265	83.50	81.00	270	89.50	87.00	62.00	11.12	29.19	25.25	9.00	8.19	12.00
	7"	E4702S-72	315	83.50	81.00	320	89.50	87.00	61.31	11.62	29.56	25.25	9.00	8.19	12.00
84	6"	E4602S-84	338	95.50	93.00	345	101.50	99.00	71.69	11.88	32.75	29.25	11.50	9.62	14.50
	7"	E4702S-84	396	95.50	93.00	403	101.50	99.00	71.00	12.38	33.12	29.25	11.50	9.62	14.50
96	6"	E4602S-96	379	107.50	105.00	386	113.50	111.00	81.31	11.88	35.56	33.25	11.50	11.00	14.50
	7"	E4702S-96	444	107.50	105.00	451	113.50	111.00	80.62	12.38	35.94	33.25	11.50	11.00	14.50

\*\* To top of discharge or bend pulleys, except foot pulley.

■ 10" bolt spacing recommended to permit washer clearance and adjustment.  
(12.5" for 84" and 96" belt widths.)



# 45° Troughed Belt Idlers, Equal Length Rolls

rubber cushion rolls (impact)

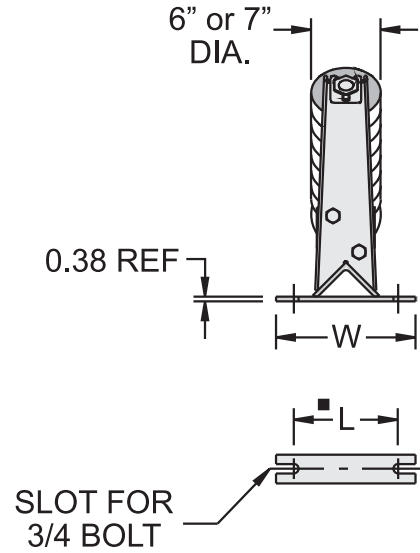
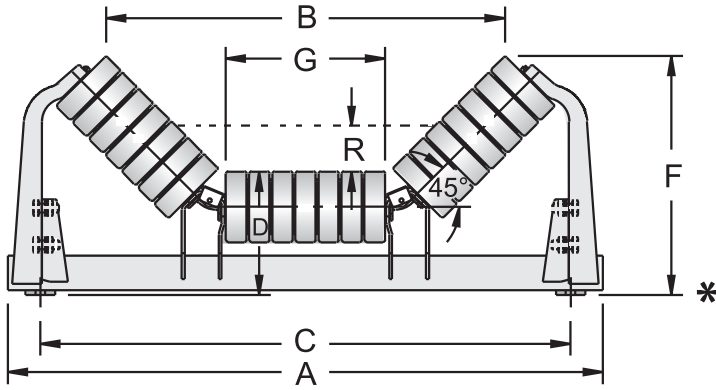

\* Demountable end bracket supplied for 36"- 96" belt widths

## CEMA E

Belt width, inches	Dia.	Idler number	Standard Base (Belt width + 9")			Wide Base (Belt width + 15")			B	D	F	G	L	R**	W
			Idler weight, pounds	A	C	Idler weight, pounds	A	C							
36	6"	E4623S-36	164	50.50	45.00	166	53.50	51.00	33.88	10.44	20.25	13.50	9.00	3.88	12.00
	7"	E4723S-36	180	50.50	45.00	182	53.50	51.00	33.12	10.94	20.62	13.50	9.00	3.88	12.00
42	6"	E4623S-42	186	56.00	51.00	189	59.50	57.00	38.56	10.44	21.69	15.50	9.00	4.62	12.00
	7"	E4723S-42	204	56.00	51.00	207	59.50	57.00	37.88	10.94	22.00	15.50	9.00	4.62	12.00
48	6"	E4623S-48	204	62.00	57.00	207	65.50	63.00	43.44	10.44	23.06	17.50	9.00	5.31	12.00
	7"	E4723S-48	224	62.00	57.00	227	65.50	63.00	42.69	10.94	23.44	17.50	9.00	5.31	12.00
54	6"	E4623S-54	223	65.50	63.00	228	71.50	69.00	48.44	10.44	24.50	19.56	9.00	6.00	12.00
	7"	E4723S-54	246	65.50	63.00	251	71.50	69.00	47.75	10.94	24.88	19.56	9.00	6.00	12.00
60	6"	E4623S-60	240	71.50	69.00	245	77.50	75.00	52.62	10.44	25.75	21.31	9.00	6.75	12.00
	7"	E4723S-60	265	71.50	69.00	270	77.50	75.00	51.94	10.94	26.12	21.31	9.00	6.75	12.00
72	6"	E4623S-72	293	83.50	81.00	299	89.50	87.00	62.00	11.19	29.25	25.19	9.00	8.19	12.00
	7"	E4723S-72	322	83.50	81.00	328	89.50	87.00	61.25	11.69	29.56	25.19	9.00	8.19	12.00
84	6"	E4623S-84	396	95.50	93.00	406	101.50	99.00	71.69	11.94	32.81	29.19	11.50	9.62	14.50
	7"	E4723S-84	429	95.50	93.00	439	101.50	99.00	70.94	12.44	33.12	29.19	11.50	9.62	14.50
96	6"	E4623S-96	444	107.50	105.00	454	113.50	111.00	81.31	11.94	35.62	33.19	11.50	11.00	14.50
	7"	E4723S-96	482	107.50	105.00	492	113.50	111.00	80.62	12.44	36.00	33.19	11.50	11.00	14.50

\*\* To top of discharge or bend pulleys, except foot pulley.

■ 10" bolt spacing recommended to permit washer clearance and adjustment.  
(12.5" for 84" and 96" belt widths.)

# 20° Troughed Belt Picking & Feeding Conveyor Idlers

steel rolls

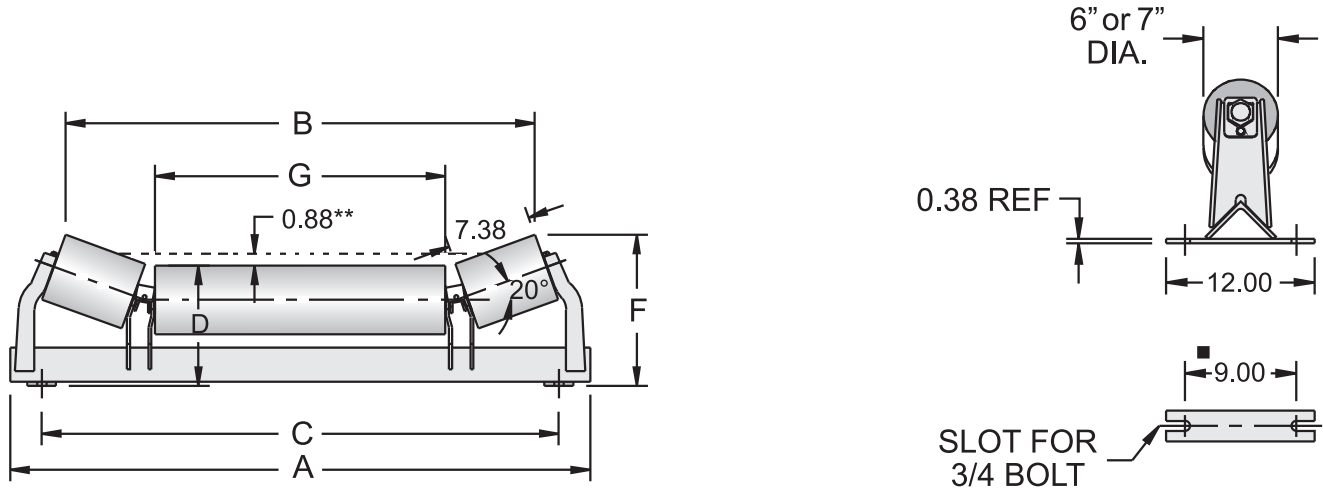

## CEMA E

Belt width, inches	Dia.	Idler number	Standard Base (Belt width + 9")			Wide Base (Belt width + 15")			B	D	F	G
			Idler weight, pounds	A	C	Idler weight, pounds	A	C				
36	6"	E4605S-36	131	50.50	45.00	133	53.50	51.00	40.81	10.44	13.12	25.25
	7"	E4705S-36	159	50.50	45.00	161	53.50	51.00	40.50	10.94	13.56	25.25
42	6"	E4605S-42	145	56.00	51.00	147	59.50	57.00	46.69	10.44	13.12	31.12
	7"	E4705S-42	177	56.00	51.00	179	59.50	57.00	46.38	10.94	13.56	31.12
48	6"	E4605S-48	159	62.00	57.00	162	65.50	63.00	52.69	10.44	13.12	37.12
	7"	E4705S-48	195	62.00	57.00	198	65.50	63.00	52.38	10.94	13.56	37.10
54	6"	E4605S-54	174	68.00	63.00	176	71.50	69.00	58.69	10.44	13.12	43.12
	7"	E4705S-54	213	68.00	63.00	216	71.50	69.00	58.38	10.94	13.56	43.12
60	6"	E4605S-60	188	74.00	69.00	190	77.50	75.00	64.69	10.44	13.12	49.12
	7"	E4705S-60	232	74.00	69.00	234	77.50	75.00	64.38	10.94	13.56	49.12
72	6"	E4605S-72	232	86.00	81.00	235	89.50	87.00	76.69	11.12	13.81	61.12
	7"	E4705S-72	283	86.00	81.00	286	89.50	87.00	76.38	11.62	14.31	61.12

\*\* To top of discharge or bend pulleys, except foot pulley.

■ 10" bolt spacing recommended to permit washer clearance and adjustment.

# 20° Troughed Belt Picking & Feeding Conveyor Idlers

steel end rolls with rubber cushion center roll

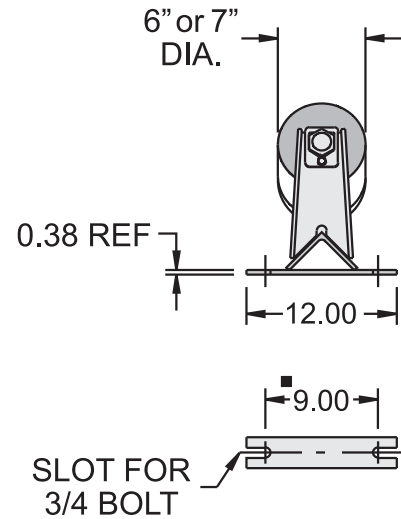
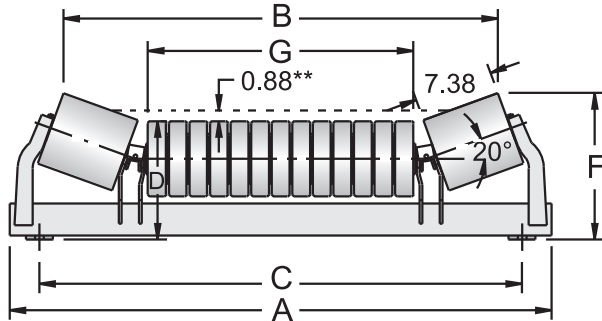

## CEMA E

Belt width, inches	Dia.	○ Idler number	Standard Base (Belt width + 9")			Wide Base (Belt width + 15")			B	D	F	G
			Idler weight, pounds	A	C	Idler weight, pounds	A	C				
36	6"	E4605RCS-36	137	50.50	45.00	139	53.50	51.00	40.81	10.44	13.12	25.19
	7"	E4705RCS-36	158	50.50	45.00	160	53.50	51.00	40.50	10.94	13.56	25.19
42	6"	E4605RCS-42	153	56.00	51.00	155	59.50	57.00	46.69	10.44	13.12	31.06
	7"	E4705RCS-42	176	56.00	51.00	178	59.50	57.00	46.38	10.94	13.56	31.06
48	6"	E4605RCS-48	169	62.00	57.00	171	65.50	63.00	52.69	10.44	13.12	37.06
	7"	E4705RCS-48	194	62.00	57.00	197	65.50	63.00	52.38	10.94	13.56	37.06
54	6"	E4605RCS-54	185	68.00	63.00	187	71.50	69.00	58.69	10.44	13.12	43.06
	7"	E4705RCS-54	213	68.00	63.00	215	71.50	69.00	58.38	10.94	13.56	43.06
60	6"	E4605RCS-60	201	74.00	69.00	204	77.50	75.00	64.69	10.44	13.12	49.06
	7"	E4705RCS-60	231	74.00	69.00	233	77.50	75.00	64.38	10.94	13.56	49.06
72	6"	E4605RCS-72	250	86.00	81.00	253	89.50	87.00	76.69	11.12	13.81	61.06
	7"	E4705RCS-72	285	86.00	81.00	288	89.50	87.00	76.38	11.62	14.31	61.06

\*\* To top of discharge or bend pulleys, except foot pulley.

■ 10" bolt spacing recommended to permit washer clearance and adjustment.

○ Available with rubber cushion end rolls; specify suffix RS. Example 4605RS-36.

# Variable Troughed Belt Idlers 10° - 35° Adjustment

steel rolls

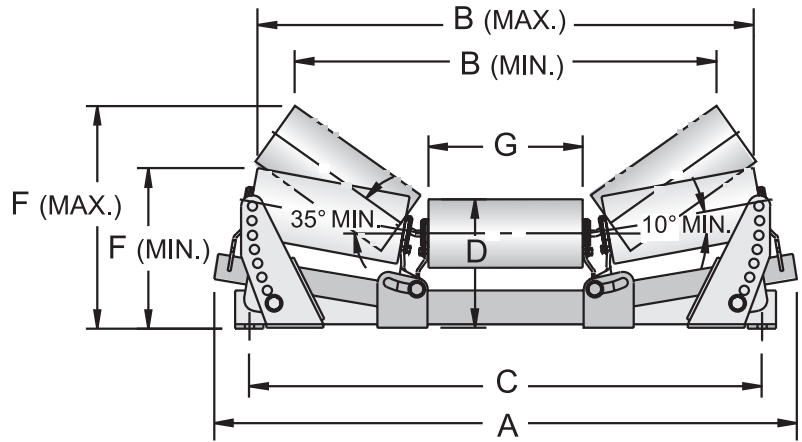
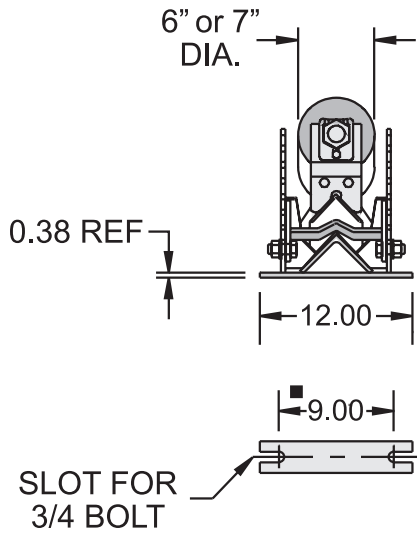

## CEMA E

Belt width, inches	Dia.	▼ Idler number	Standard Base (Belt width + 9")		Wide Base (Belt width + 15")			B		D	F		G	
			Idler weight, pounds	A	C	Idler weight, pounds	A	C	MIN.		MAX.	MIN.		MAX.
36	6"	E4606S-36	202	51.19	45.00	221	51.19	45.00	36.94	43.62	11.31	14.06	19.56	13.56
	7"	E4706S-36	232	51.19	45.00	235	51.19	45.00	36.38	43.44	11.81	14.56	19.94	13.56
42	6"	E4606S-42	218	57.12	51.00	242	57.12	51.00	42.31	49.56	11.31	14.44	20.69	15.56
	7"	E4706S-42	252	57.12	51.00	255	57.12	51.00	41.75	49.38	11.81	14.94	21.06	15.56
48	6"	E4606S-48	237	63.31	57.00	263	63.31	57.00	47.69	55.69	11.31	14.81	21.94	17.56
	7"	E4706S-48	276	63.31	57.00	279	63.31	57.00	47.12	55.31	11.81	15.37	22.31	17.56
54	6"	E4606S-54	254	69.44	63.00	283	69.44	63.00	53.12	61.75	11.31	15.19	23.12	19.62
	7"	E4706S-54	296	69.44	63.00	300	69.44	63.00	52.50	61.56	11.81	15.69	23.50	19.62
60	6"	E4606S-60	277	74.88	69.00	308	74.88	69.00	57.62	67.06	11.31	15.56	24.06	21.38
	7"	E4706S-60	319	74.88	69.00	324	74.88	69.00	57.06	66.69	11.81	16.06	24.50	21.38
72	6"	E4606S-72	306	86.44	81.00	344	86.44	81.00	67.88	78.56	11.31	16.25	25.25	25.25
	7"	E4706S-72	358	86.44	81.00	363	86.44	81.00	67.31	78.38	11.81	16.75	26.62	25.25
84	6"	E4606S-84	394	97.81	93.00	437	97.81	93.00	78.38	90.00	12.06	17.44	29.06	29.25
	7"	E4706S-84	449	97.81	93.00	455	97.81	93.00	77.81	89.81	12.56	17.94	29.50	29.25
96	6"	E4606S-96	433	109.69	105.00	481	109.69	105.00	88.94	101.88	12.06	18.12	31.31	33.25
	7"	E4706S-96	493	109.69	105.00	499	109.69	105.00	88.38	101.69	12.56	18.62	31.75	33.25

■ 10" bolt spacing recommended to permit washer clearance and adjustment.

▼ 1/4" thick steel rolls standard.

# Flat Belt Idlers

steel rolls

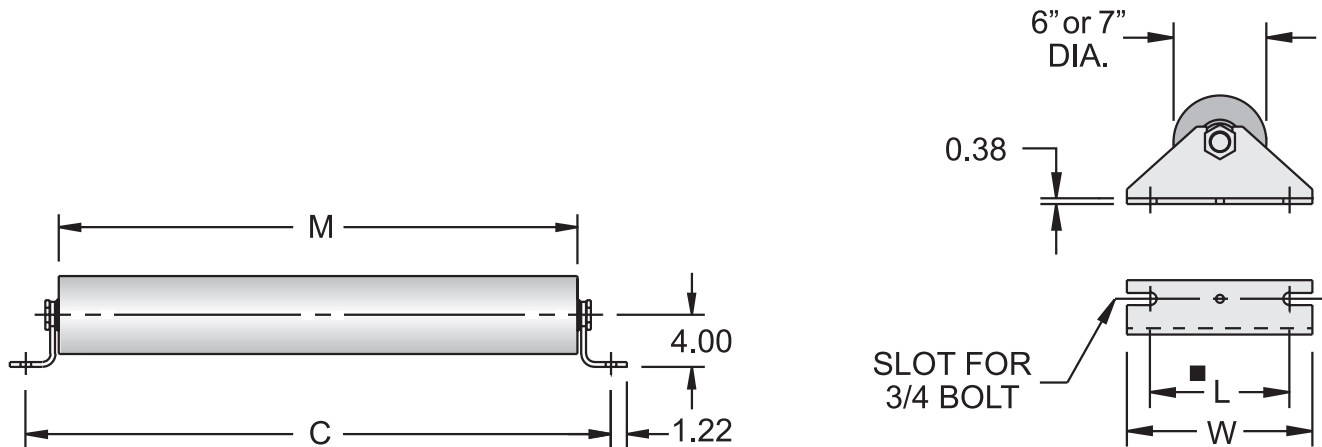

## CEMA E

Belt width, inches	Dia.	Idler number	Standard Base (Belt width + 9")			Wide Base (Belt width + 15")			L	W
			Idler weight, pounds	Inches		Idler weight, pounds	Inches			
36	6"	E4613S-36	91	45.00	39.88	102	51.00	45.88	9.00	12.00
	7"	E4713S-36	118	45.00	39.88	132	51.00	45.88	9.00	12.00
42	6"	E4613S-42	102	51.00	45.88	112	57.00	51.88	9.00	12.00
	7"	E4713S-42	132	51.00	45.88	146	57.00	51.88	9.00	12.00
48	6"	E4613S-48	112	57.00	51.88	122	63.00	57.88	9.00	12.00
	7"	E4713S-48	146	57.00	51.88	160	63.00	57.88	9.00	12.00
54	6"	E4613S-54	122	63.00	57.88	132	69.00	63.88	9.00	12.00
	7"	E4713S-54	160	63.00	57.88	174	69.00	63.88	9.00	12.00
60	6"	E4613S-60	132	69.00	63.88	143	75.00	69.88	9.00	12.00
	7"	E4713S-60	174	69.00	63.88	188	75.00	69.88	9.00	12.00
72	6"	E4613S-72	154	81.00	75.88	174	87.00	81.88	9.00	12.00
	7"	E4713S-72	202	81.00	75.88	228	87.00	81.88	9.00	12.00
84	6"	E4613S-84	185	93.00	87.88	196	99.00	93.88	11.50	14.50
	7"	E4713S-84	243	93.00	87.88	258	99.00	93.88	11.50	14.50
96	6"	E4613S-96	207	105.00	99.88	218	111.00	105.88	11.50	14.50
	7"	E4713S-96	272	105.00	99.88	287	111.00	105.88	11.50	14.50

■ 10" bolt spacing recommended to permit adjustment.  
(12.5" for 84" and 96" belt widths.)

# Live Shaft Idlers

steel rolls, live shaft type

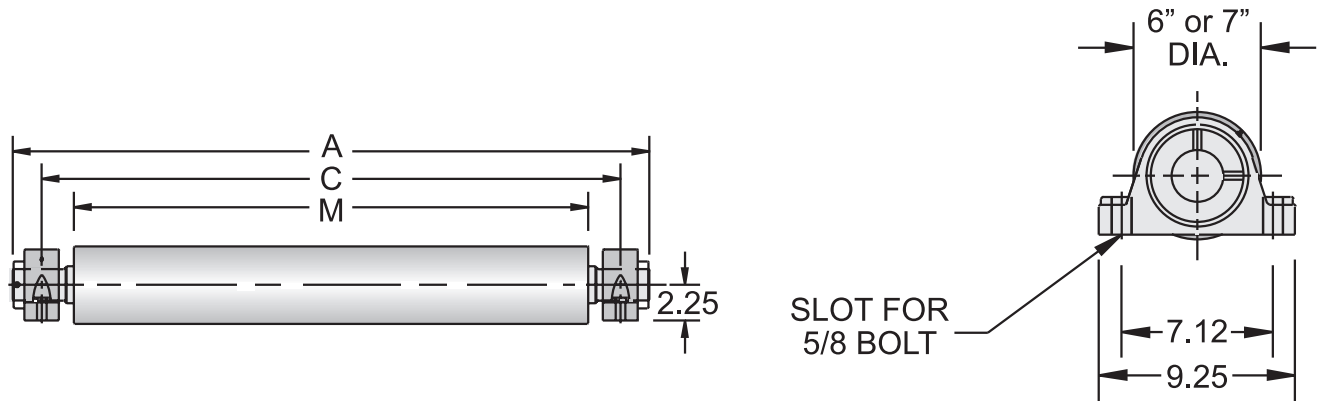

## CEMA E

Belt width, inches	Dia.	Idler number	Standard Base (Belt width + 9")				Wide Base (Belt width + 15")			
			Idler weight, pounds*	A	C	M	Idler weight, pounds*	A	C	M
				Inches				Inches		
36	6"	E4613L-36	162	49.50	45.00	40.00	178	55.50	51.00	46.00
	7"	E4713L-36	177	49.50	45.00	40.00	193	55.50	51.00	46.00
42	6"	E4613L-42	178	55.50	51.00	46.00	193	61.50	57.00	52.00
	7"	E4713L-42	193	55.50	51.00	46.00	210	61.50	57.00	52.00
48	6"	E4613L-48	193	61.50	57.00	52.00	209	67.50	63.00	58.00
	7"	E4713L-48	210	61.50	57.00	52.00	227	67.50	63.00	58.00
54	6"	E4613L-54	209	67.50	63.00	58.00	224	73.50	69.00	64.00
	7"	E4713L-54	227	67.50	63.00	58.00	244	73.50	69.00	64.00
60	6"	E4613L-60	224	73.50	69.00	64.00	240	79.50	75.00	70.00
	7"	E4713L-60	244	73.50	69.00	64.00	261	79.50	75.00	70.00
72	6"	E4613L-72	256	85.50	81.00	76.00	271	91.50	87.00	82.00
	7"	E4713L-72	278	85.50	81.00	76.00	295	91.50	87.00	82.00
84	6"	E4613L-84	287	97.50	93.00	88.00	302	103.50	99.00	94.00
	7"	E4713L-84	312	97.50	93.00	88.00	329	103.50	99.00	94.00
96	6"	E4613L-96	318	109.50	105.00	100.00	334	115.50	111.00	106.00
	7"	E4713L-96	346	109.50	105.00	100.00	363	115.50	111.00	106.00

\* Weight includes pillow blocks (P-B22439H).

# Live Shaft Idlers

rubber cushion rolls, live shaft type

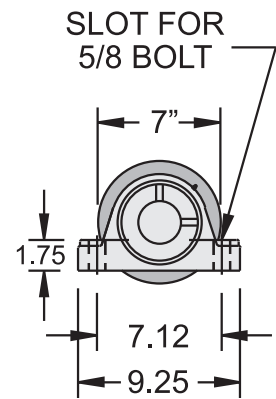
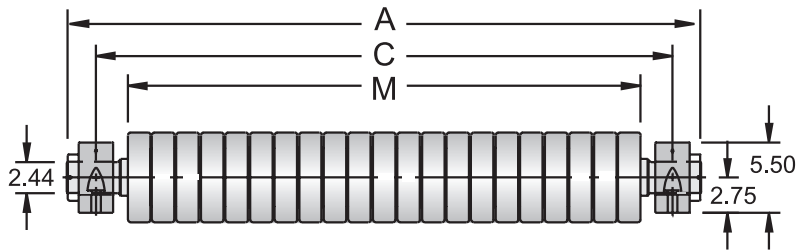

## CEMA E

Belt width, inches	Dia.	Idler number	Standard Base (Belt width + 9")			Wide Base (Belt width + 15")				
			Idler weight, pounds*	A	C	M	Idler weight, pounds*	A	C	M
				Inches				Inches		
36	7"	E4716-36	235	49.50	45.00	40.50	258	55.50	51.00	46.50
42	7"	E4716-42	258	55.50	51.00	46.50	281	61.50	57.00	52.50
48	7"	E4716-48	281	61.50	57.00	52.50	304	67.50	63.00	58.50
54	7"	E4716-54	304	67.50	63.00	58.50	328	73.50	69.00	64.50
60	7"	E4716-60	328	73.50	69.00	64.50	351	79.50	75.00	70.50
72	7"	E4716-72	374	85.50	81.00	76.50	397	91.50	87.00	82.50
84	7"	E4716-84	409	97.50	93.00	88.50	432	103.50	99.00	94.50
96	7"	E4716-96	456	109.50	105.00	100.50	479	115.50	111.00	106.50

\* Weight includes pillow blocks (P-B22439H).

# Flat Belt Idlers

rubber cushion rolls

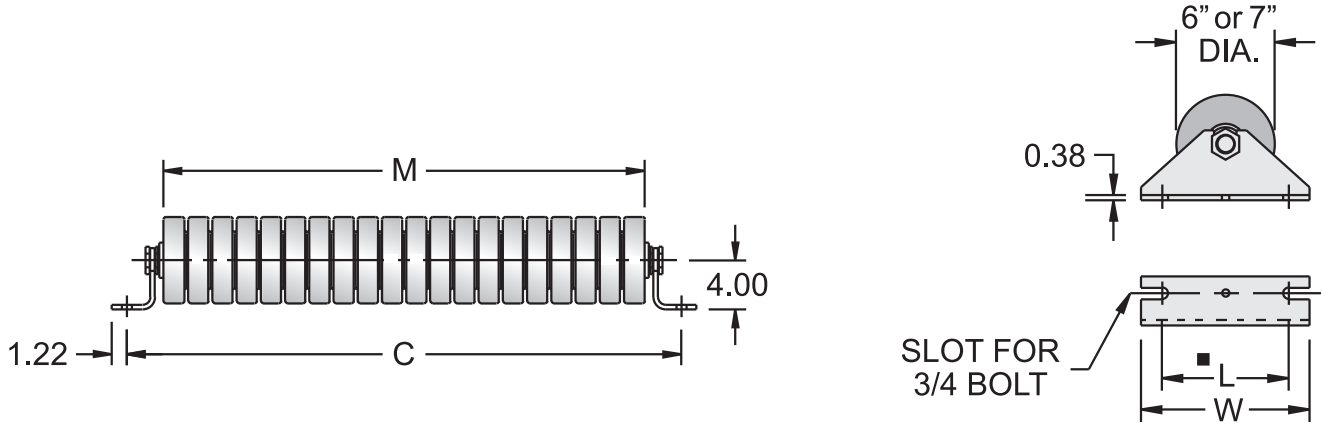

## CEMA E

Belt width, inches	Dia.	Idler number	Standard Base (Belt width + 9")			Wide Base (Belt width + 15")			L	W
			Idler weight, pounds	Inches		Idler weight, pounds	Inches			
				C	M		C	M		
36	6"	E4615S-36	121	45.00	39.75	137	51.00	45.75	9.00	12.00
	7"	E4715S-36	135	45.00	39.75	154	51.00	45.75	9.00	12.00
42	6"	E4615S-42	137	51.00	45.75	153	57.00	51.75	9.00	12.00
	7"	E4715S-42	154	51.00	45.75	173	57.00	51.75	9.00	12.00
48	6"	E4615S-48	153	57.00	51.75	167	63.00	57.75	9.00	12.00
	7"	E4715S-48	173	57.00	51.75	189	63.00	57.75	9.00	12.00
54	6"	E4615S-54	167	63.00	57.75	182	69.00	63.75	9.00	12.00
	7"	E4715S-54	189	63.00	57.75	206	69.00	63.75	9.00	12.00
60	6"	E4615S-60	182	69.00	63.75	197	75.00	69.75	9.00	12.00
	7"	E4715S-60	206	69.00	63.75	223	75.00	69.75	9.00	12.00
72	6"	E4615S-72	209	81.00	75.75	231	87.00	81.75	9.00	12.00
	7"	E4715S-72	238	81.00	75.75	262	87.00	81.75	9.00	12.00
84	6"	E4615S-84	244	93.00	87.75	257	99.00	93.75	11.50	14.50
	7"	E4715S-84	277	93.00	87.75	292	99.00	93.75	11.50	14.50
96	6"	E4615S-96	269	105.00	99.75	282	111.00	105.75	11.50	14.50
	7"	E4715S-96	307	105.00	99.75	322	111.00	105.75	11.50	14.50

■ 10" bolt spacing recommended to permit adjustment.  
(12.5" for 84" and 96" belt widths.)



# Flat Belt Training Idlers

positive action type

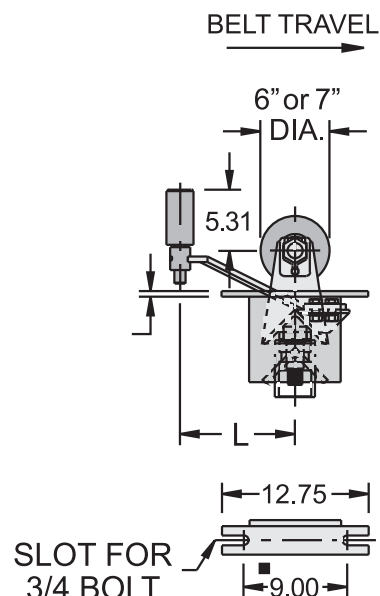
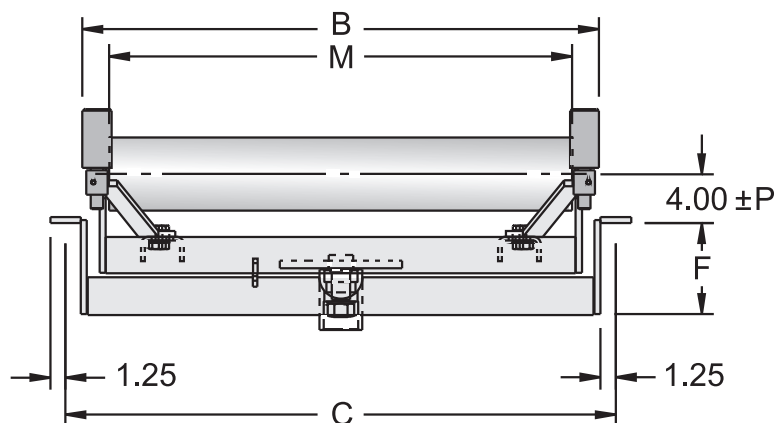

## CEMA E

Belt width, inches	Dia.	Idler number	Standard Base (Belt width + 9")		Wide Base (Belt width + 15")		B	F	L	M	P
			Idler weight, pounds	C	Idler weight, pounds	C					
36	6"	E4614S-36	230	45.00	236	51.00	42.12	7.44	10.00	37.88	0.19
	7"	E4714S-36	255	45.00	262	51.00	42.12	7.44	10.00	37.88	0.19
42	6"	E4614S-42	254	51.00	261	57.00	48.12	7.44	10.00	43.88	0.19
	7"	E4714S-42	282	51.00	289	57.00	48.12	7.44	10.00	43.88	0.19
48	6"	E4614S-48	283	57.00	290	63.00	54.12	7.44	10.00	49.88	0.19
	7"	E4714S-48	316	57.00	323	63.00	54.12	7.44	10.00	49.88	0.19
54	6"	E4614S-54	309	63.00	315	69.00	60.00	7.44	15.00	55.88	0.19
	7"	E4714S-54	344	63.00	351	69.00	60.00	7.44	15.00	55.88	0.19
60	6"	E4614S-60	333	69.00	339	75.00	66.00	7.44	15.00	61.88	0.25
	7"	E4714S-60	374	69.00	380	75.00	66.00	7.44	15.00	61.88	0.25
72	6"	E4614S-72	456	81.00	462	87.00	78.00	9.38	15.00	73.88	0.25
	7"	E4714S-72	503	81.00	509	87.00	78.00	9.38	15.00	73.88	0.25

■ 10" bolt spacing recommended to permit adjustment.

# Return Belt Beater Idlers

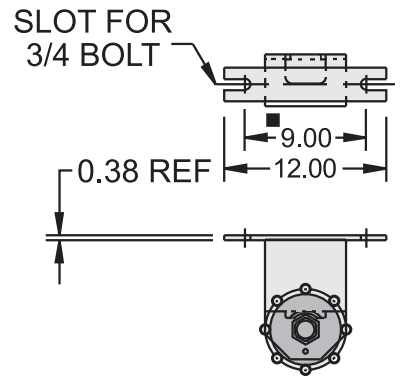
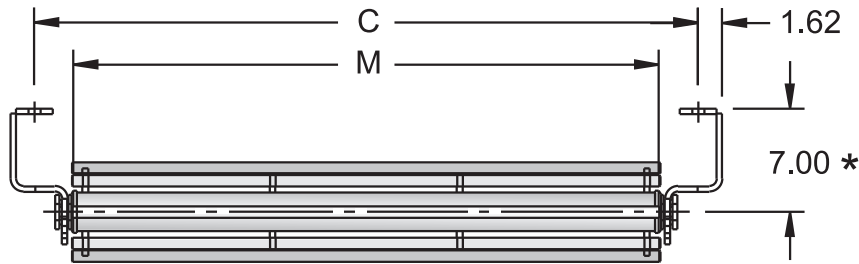

## CEMA E

Belt width, inches	Dia.	Idler number	Standard Base (Belt width + 9")			Wide Base (Belt width + 15")		
			Idler weight, pounds	C	M	Idler weight, pounds	C	M
			Inches					
36	6"	E4619S-36	101	45.00	39.88	112	51.00	45.88
	7"	E4719S-36	104	45.00	39.88	115	51.00	45.88
42	6"	E4619S-42	112	51.00	45.88	123	57.00	51.88
	7"	E4719S-42	115	51.00	45.88	126	57.00	51.88
48	6"	E4619S-48	123	57.00	51.88	135	63.00	57.88
	7"	E4719S-48	126	57.00	51.88	139	63.00	57.88
54	6"	E4619S-54	135	63.00	57.88	146	69.00	63.88
	7"	E4719S-54	139	63.00	57.88	151	69.00	63.88
60	6"	E4619S-60	146	69.00	63.88	157	75.00	69.88
	7"	E4719S-60	151	69.00	63.88	162	75.00	69.88
72	6"	E4619S-72	169	81.00	75.88	179	87.00	81.88
	7"	E4719S-72	174	81.00	75.88	184	87.00	81.88
84	6"	E4619S-84	192	93.00	87.88	202	99.00	93.88
	7"	E4719S-84	198	93.00	87.88	208	99.00	93.88
96	6"	E4619S-96	214	105.00	99.88	224	111.00	105.88
	7"	E4719S-96	220	105.00	99.88	230	111.00	105.88

■ 10" bolt spacing recommended to permit adjustment.

\* 1.75" and 4.25" drops can be furnished if specified.

# Return Belt Idlers

steel rolls

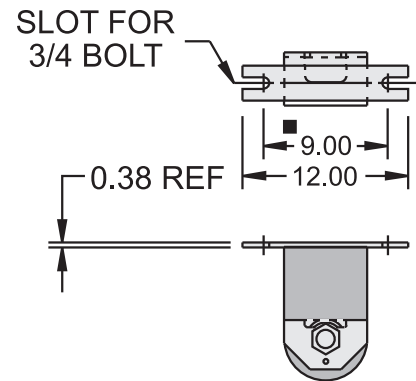
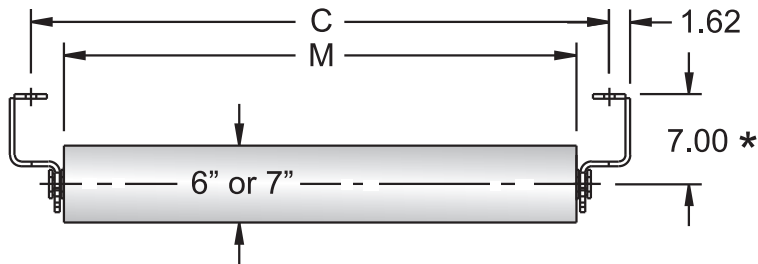

## CEMA E

Belt width, inches	Dia.	Idler number	Standard Base (Belt width + 9")			Wide Base (Belt width + 15")		
			Idler weight, pounds	C Inches	M Inches	Idler weight, pounds	C Inches	M Inches
36	6"	E4617S-36	92	45.00	39.88	103	51.00	45.88
	7"	E4717S-36	119	45.00	39.88	133	51.00	45.88
42	6"	E4617S-42	103	51.00	45.88	113	57.00	51.88
	7"	E4717S-42	133	51.00	45.88	147	57.00	51.88
48	6"	E4617S-48	113	57.00	51.88	123	63.00	57.88
	7"	E4717S-48	147	57.00	51.88	161	63.00	57.88
54	6"	E4617S-54	123	63.00	57.88	133	69.00	63.88
	7"	E4717S-54	161	63.00	57.88	175	69.00	63.88
60	6"	E4617S-60	133	69.00	63.88	143	75.00	69.88
	7"	E4717S-60	175	69.00	63.88	189	75.00	69.88
72	6"	E4617S-72	155	81.00	75.88	174	87.00	81.88
	7"	E4717S-72	203	81.00	75.88	228	87.00	81.88
84	6"	E4617S-84	223	93.00	87.88	236	99.00	93.88
	7"	E4717S-84	244	93.00	87.88	258	99.00	93.88
96	6"	E4617S-96	250	105.00	99.88	263	111.00	105.88
	7"	E4717S-96	273	105.00	99.88	287	111.00	105.88

■ 10" bolt spacing recommended to permit adjustment.

\* 1.75" and 4.25" drops can be furnished if specified.

# Return Belt Idlers

rubber tread rolls, massed ends

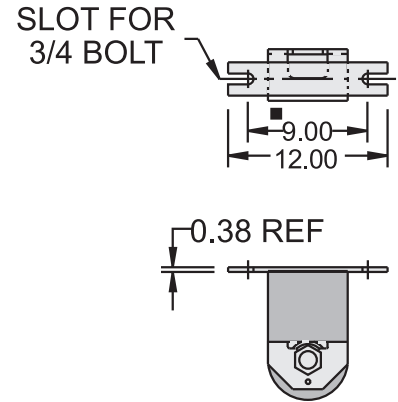
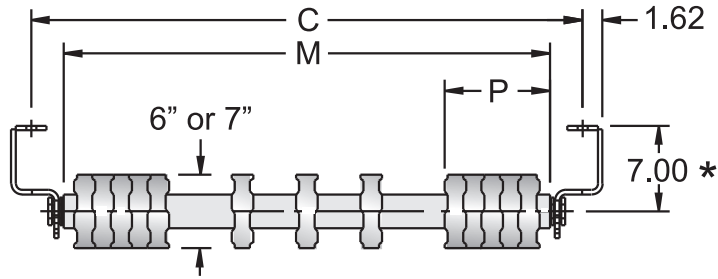

## CEMA E

Belt width, inches	Dia.	▽ Idler number	Standard Base (Belt width + 9")			Wide Base (Belt width + 15")			Number of treads		
			Idler weight, pounds	C	M	P	Idler weight, pounds	C		M	P
				Inches				Inches			
36	6"	E4618S-36	81	45.00	39.69	8.62	87	51.00	45.69	9.62	13
	7"	E4718S-36	92	45.00	39.69	8.62	97	51.00	45.69	9.62	13
42	6"	E4618S-42	88	51.00	45.69	8.62	94	57.00	51.69	9.62	14
	7"	E4718S-42	100	51.00	45.69	8.62	106	57.00	51.69	9.62	14
48	6"	E4618S-48	96	57.00	51.69	8.62	102	63.00	57.69	9.62	15
	7"	E4718S-48	108	57.00	51.69	8.62	114	63.00	57.69	9.62	15
54	6"	E4618S-54	103	63.00	57.69	8.62	109	69.00	63.69	9.62	16
	7"	E4718S-54	116	63.00	57.69	8.62	122	69.00	63.69	9.62	16
60	6"	E4618S-60	111	69.00	63.69	8.62	117	75.00	69.69	9.62	17
	7"	E4718S-60	125	69.00	63.69	8.62	131	75.00	69.69	9.62	17
72	6"	E4618S-72	126	81.00	75.69	8.62	142	87.00	81.69	9.62	19
	7"	E4718S-72	141	81.00	75.69	8.62	158	87.00	81.69	9.62	19
84	6"	E4618S-84	152	93.00	87.69	8.62	158	99.00	93.69	9.62	21
	7"	E4718S-84	169	93.00	87.69	8.62	176	99.00	93.69	9.62	21
96	6"	E4618S-96	168	105.00	99.69	8.62	175	111.00	105.69	9.62	23
	7"	E4718S-96	187	105.00	99.69	8.62	194	111.00	105.69	9.62	23

■ 10" bolt spacing recommended to permit adjustment.

\* 1.75" and 4.25" drops can be furnished if specified.

▽ 6" and 7" diameter urethane treads available.

# Return Belt Training Idlers

steel rolls, positive action type

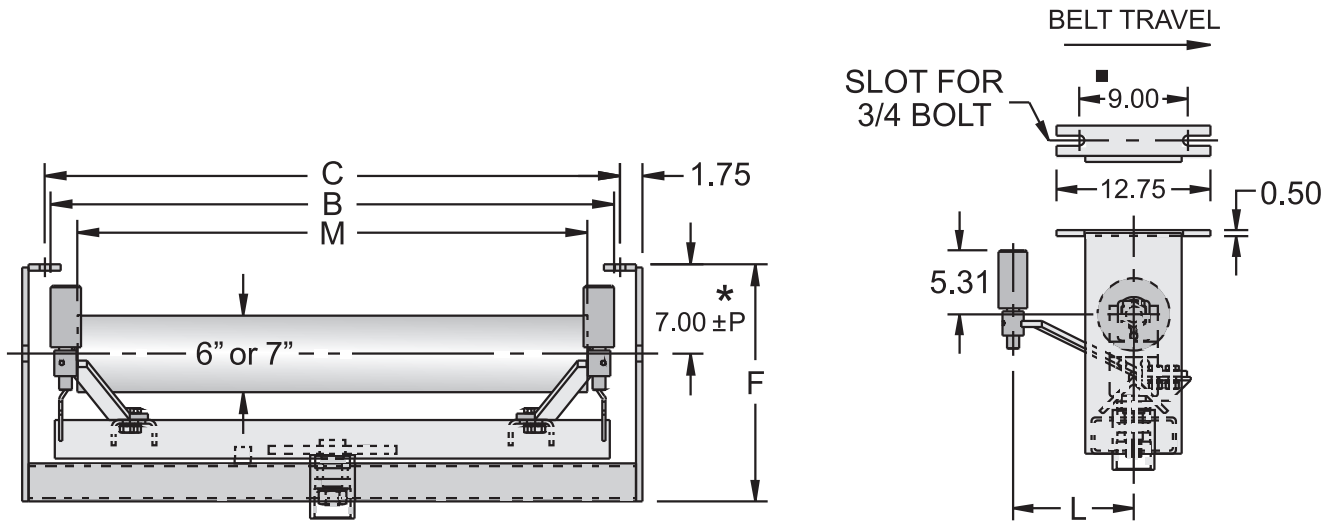

## CEMA E

Belt width, inches	Dia.	Idler number	Standard Base (Belt width + 9")		Wide Base (Belt width + 15")		B	F	L	M	P
			Idler weight, pounds	C	Idler weight, pounds	C					
36	6"	E4620S-36	264	45.00	272	51.00	44.12	18.56	10.00	39.88	0.19
	7"	E4720S-36	291	45.00	299	51.00	44.12	18.56	10.00	39.88	0.19
42	6"	E4620S-42	323	51.00	331	57.00	50.12	18.56	10.00	45.88	0.19
	7"	E4720S-42	353	51.00	361	57.00	50.12	18.56	10.00	45.88	0.19
48	6"	E4620S-48	345	57.00	353	63.00	56.12	18.56	10.00	51.88	0.19
	7"	E4720S-48	380	57.00	388	63.00	56.12	18.56	10.00	51.88	0.19
54	6"	E4620S-54	364	63.00	372	69.00	62.00	18.56	15.00	57.88	0.19
	7"	E4720S-54	402	63.00	410	69.00	62.00	18.56	15.00	57.88	0.19
60	6"	E4620S-60	392	69.00	400	75.00	68.00	18.56	15.00	63.88	0.25
	7"	E4720S-60	433	69.00	441	75.00	68.00	18.56	15.00	63.88	0.25
72	6"	E4620S-72	544	81.00	555	87.00	80.00	19.69	15.00	75.88	0.25
	7"	E4720S-72	592	81.00	604	87.00	80.00	19.69	15.00	75.88	0.25

- 10" bolt spacing recommended to permit adjustment.
- \* 4.25" drop can be furnished if specified.

# Return Belt Idlers

rubber tread rolls, positive action type, massed ends

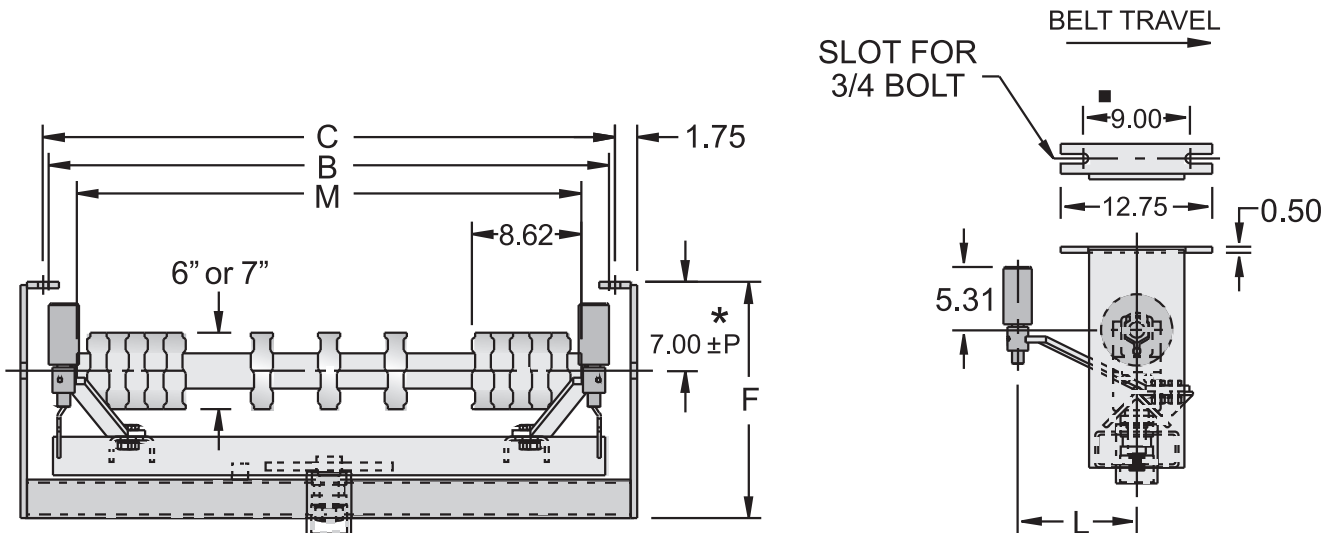

# CEMA E

Belt width, inches	Dia.	▽ Idler number	Standard Base (Belt width + 9")		Wide Base (Belt width + 15")		B	F	L	M	P	Number of treads
			Idler weight, pounds	C	Idler weight, pounds	C						
36	6"	E4621S-36	253	45.00	261	51.00	44.12	18.56	10.00	39.69	0.19	13
	7"	E4721S-36	264	45.00	272	51.00	44.12	18.56	10.00	39.69	0.19	13
42	6"	E4621S-42	308	51.00	316	57.00	50.12	18.56	10.00	45.69	0.19	14
	7"	E4721S-42	320	51.00	328	57.00	50.12	18.56	10.00	45.69	0.19	14
48	6"	E4621S-48	329	57.00	337	63.00	56.12	18.56	10.00	51.69	0.19	15
	7"	E4721S-48	341	57.00	349	63.00	56.12	18.56	10.00	51.69	0.19	15
54	6"	E4621S-54	344	63.00	352	69.00	62.00	18.56	15.00	57.69	0.19	16
	7"	E4721S-54	357	63.00	365	69.00	62.00	18.56	15.00	57.69	0.19	16
60	6"	E4621S-60	369	69.00	377	75.00	68.00	18.56	15.00	63.69	0.25	17
	7"	E4721S-60	383	69.00	391	75.00	68.00	18.56	15.00	63.69	0.25	17
72	6"	E4621S-72	514	81.00	525	87.00	80.00	19.69	15.00	75.69	0.25	19
	7"	E4721S-72	529	81.00	541	87.00	80.00	19.69	15.00	75.69	0.25	19

- 10" bolt spacing recommended to permit adjustment.
- \* 4.25" drop can be furnished if specified.
- ▽ 6" and 7" diameter urethane treads available.

# Return Belt Training Idlers

steel rolls, actuating shoe type

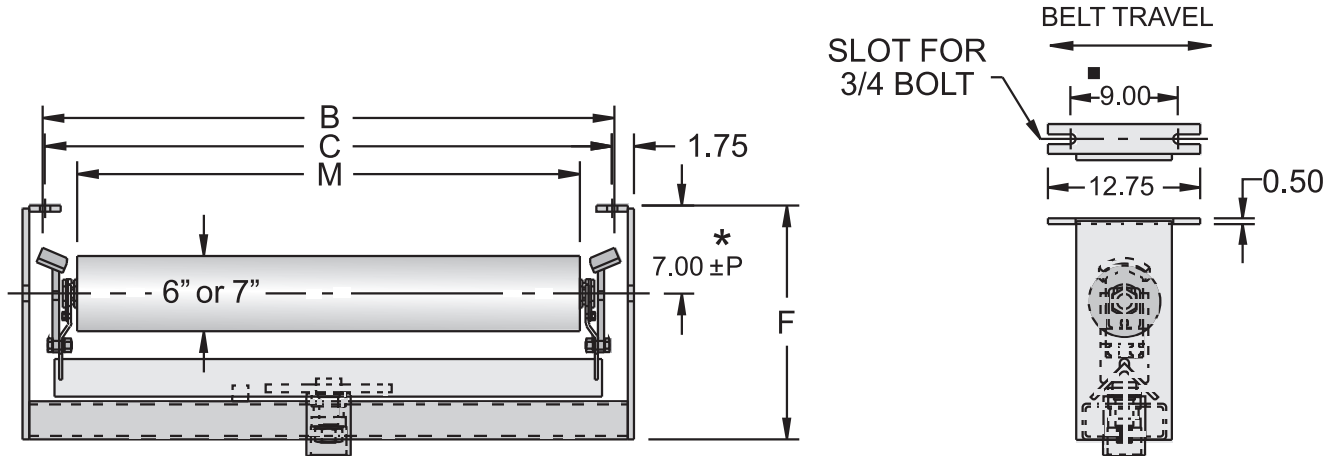

## CEMA E

Belt width, inches	Dia.	Idler number	Standard Base (Belt width + 9")		Wide Base (Belt width + 15")		B	F	M	P
			Idler weight, pounds	C	Idler weight, pounds	C				
36	6"	E4626S-36	251	45.00	259	51.00	45.38	18.56	39.88	0.19
	7"	E4726S-36	278	45.00	286	51.00	45.38	18.56	39.88	0.19
42	6"	E4626S-42	310	51.00	318	57.00	51.38	18.56	45.88	0.19
	7"	E4726S-42	340	51.00	348	57.00	51.38	18.56	45.88	0.19
48	6"	E4626S-48	332	57.00	340	63.00	57.38	18.56	51.88	0.19
	7"	E4726S-48	367	57.00	375	63.00	57.38	18.56	51.88	0.19
54	6"	E4626S-54	351	63.00	359	69.00	63.38	18.56	57.88	0.19
	7"	E4726S-54	389	63.00	397	69.00	63.38	18.56	57.88	0.19
60	6"	E4626S-60	379	69.00	387	75.00	69.38	18.56	63.88	0.25
	7"	E4726S-60	420	69.00	428	75.00	69.38	18.56	63.88	0.25
72	6"	E4626S-72	531	81.00	542	87.00	81.38	19.69	75.88	0.25
	7"	E4726S-72	571	81.00	583	87.00	81.38	19.69	75.88	0.25

■ 10" bolt spacing recommended to permit adjustment.

\* 4.25" drop can be furnished if specified.

# Return Belt Training Idlers

rubber tread rolls, actuating shoe type, massed ends

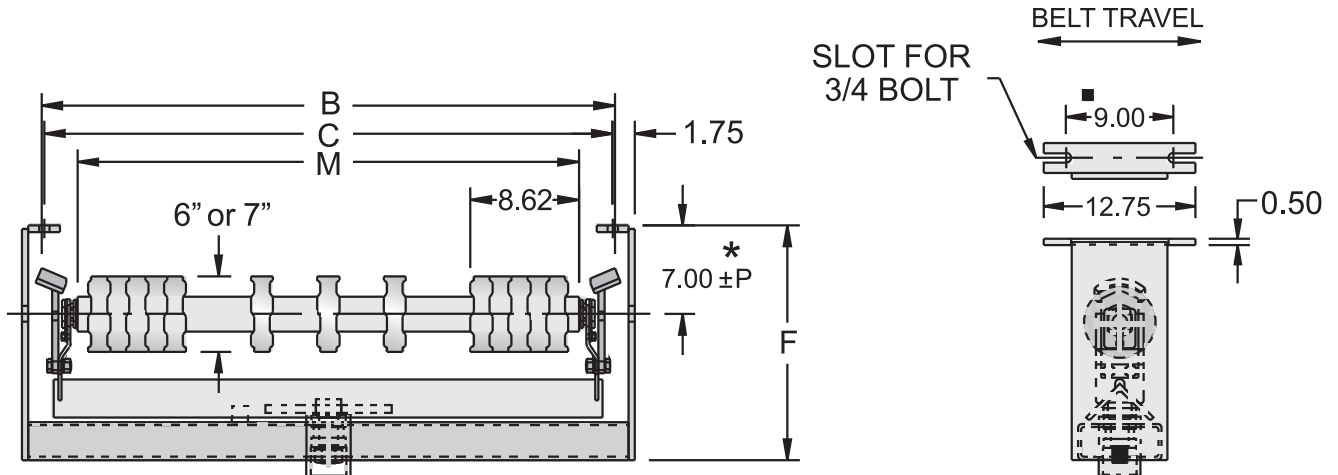

## CEMA E

Belt width, inches	Dia.	▽ Idler number	Standard Base (Belt width + 9")		Wide Base (Belt width + 15")		B	F	M	P	Number of treads
			Idler weight, pounds	C	Idler weight, pounds	C					
36	6"	E4627S-36	240	45.00	248	51.00	45.38	18.56	39.69	0.19	13
	7"	E4727S-36	251	45.00	259	51.00	45.38	18.56	39.69	0.19	13
42	6"	E4627S-42	295	51.00	303	57.00	51.38	18.56	45.69	0.19	14
	7"	E4727S-42	307	51.00	315	57.00	51.38	18.56	45.69	0.19	14
48	6"	E4627S-48	316	57.00	324	63.00	57.38	18.56	51.69	0.19	15
	7"	E4727S-48	328	57.00	336	63.00	57.38	18.56	51.69	0.19	15
54	6"	E4627S-54	331	63.00	339	69.00	63.38	18.56	57.69	0.19	16
	7"	E4727S-54	344	63.00	352	69.00	63.38	18.56	57.69	0.19	16
60	6"	E4627S-60	356	69.00	364	75.00	69.38	18.56	63.69	0.25	17
	7"	E4727S-60	370	69.00	378	75.00	69.38	18.56	63.69	0.25	17
72	6"	E4627S-72	501	81.00	512	87.00	81.38	19.69	75.69	0.25	19
	7"	E4727S-72	516	81.00	528	87.00	81.38	19.69	75.69	0.25	19

■ 10" bolt spacing recommended to permit adjustment.

\* 4.25" drop can be furnished if specified.

▽ 6" and 7" diameter urethane treads available.



# 5° V-Return Idlers

steel rolls, v-return

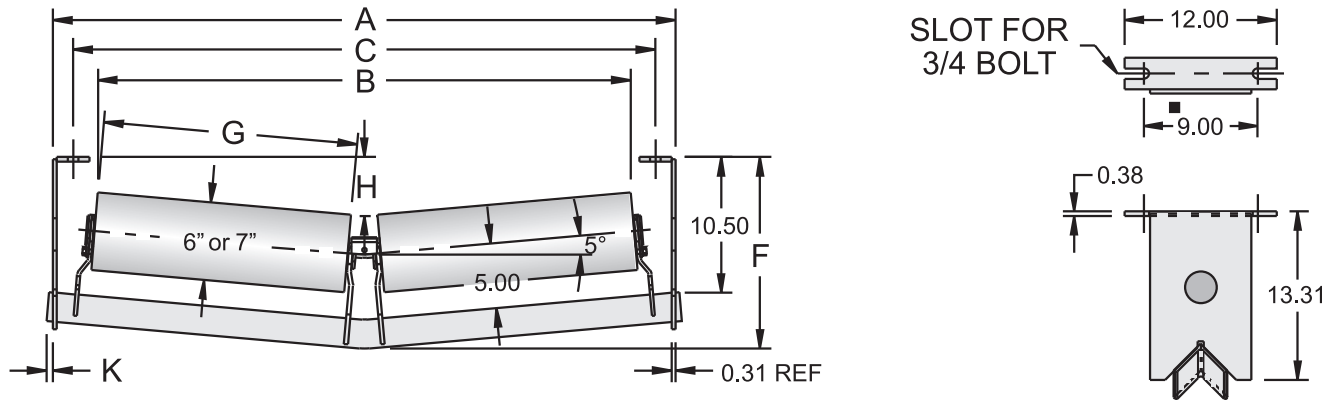

## CEMA E

** Belt width, inches	Dia.	Idler number	Idler weight, pounds	A	B	C	F	G	H	K
				Inches						
36	6"	E4664S-36	134	48.12	41.19	45.00	15.19	19.62	4.56	.50
	7"	E4764S-36	161	48.12	41.06	45.00	15.19	19.62	4.06	.50
42	6"	E4664S-42	152	54.12	47.12	51.00	15.81	22.62	4.81	.56
	7"	E4764S-42	183	54.12	47.06	51.00	15.81	22.62	4.31	.56
48	6"	E4664S-48	166	60.12	53.00	57.00	16.06	25.56	5.12	.56
	7"	E4764S-48	200	60.12	52.88	57.00	16.06	25.56	4.62	.56
54	6"	E4664S-54	191	66.12	60.38	63.00	16.38	29.25	5.38	.56
	7"	E4764S-54	230	66.12	60.25	63.00	16.38	29.25	4.88	.56
60	6"	E4664S-60	203	72.12	64.94	69.00	16.62	31.56	5.62	.56
	7"	E4764S-60	245	72.12	64.88	69.00	16.62	31.56	5.12	.56
66	6"	E4664S-66	218	78.12	70.94	75.00	16.88	34.56	5.88	.56
	7"	E4764S-66	264	78.12	70.88	75.00	16.88	34.56	5.38	.56
72	6"	E4664S-72	236	84.12	76.94	81.00	17.81	37.56	6.12	.62
	7"	E4764S-72	286	84.12	76.81	81.00	17.81	37.56	5.62	.62
78	6"	E4664S-78	251	90.12	82.88	87.00	18.06	40.56	6.44	.62
	7"	E4764S-78	305	90.12	82.81	87.00	18.06	40.56	5.94	.62
84	6"	E4664S-84	267	96.12	89.50	93.00	18.31	43.88	6.69	.62
	7"	E4764S-84	325	96.12	89.44	93.00	18.31	43.88	6.19	.62
90	6"	E4664S-90	281	102.12	95.44	99.00	18.62	46.88	6.94	.62
	7"	E4764S-90	344	102.12	95.38	99.00	18.62	46.88	6.44	.62
96	6"	E4664S-96	296	108.12	101.44	105.00	18.88	49.88	7.19	.62
	7"	E4764S-96	362	108.12	101.38	105.00	18.88	49.88	6.69	.62
102	6"	E4664S-102	330	114.12	107.44	111.00	19.12	52.88	7.44	.62
	7"	E4764S-102	400	114.12	107.31	111.00	19.12	52.88	6.94	.62

■ 10" bolt spacing recommended to permit adjustment.

\*\* For belt width + 15" mounting use next higher belt width.

# 10° V-Return Idlers

steel rolls, v-return

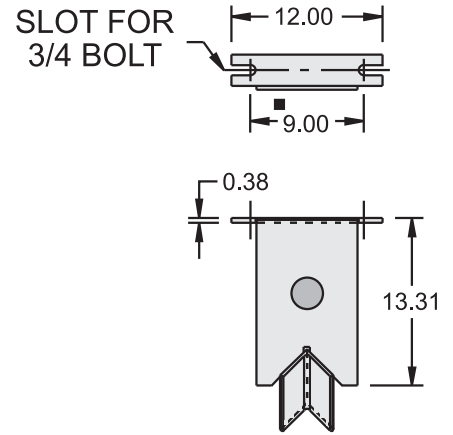
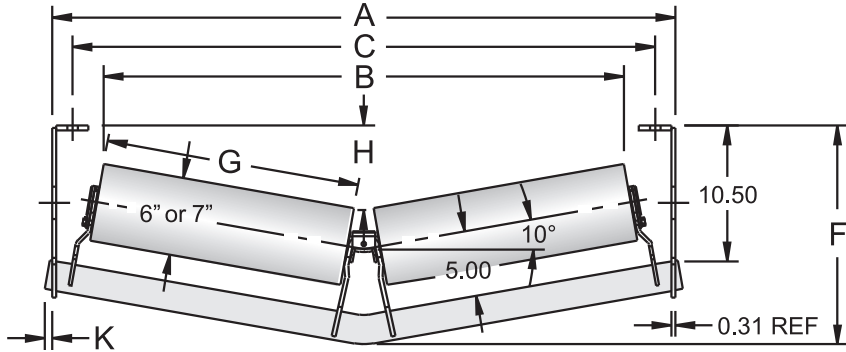

## CEMA E

** Belt width, inches	Dia.	Idler number	Idler weight, pounds	A	B	C	F	G	H	K
				Inches						
36	6"	E4665S-36	135	48.12	40.25	45.00	17.31	19.62	6.62	.75
	7"	E4765S-36	162	48.12	40.06	45.00	17.31	19.62	6.12	.75
42	6"	E4665S-42	153	54.12	46.12	51.00	18.19	22.62	7.12	.81
	7"	E4765S-42	184	54.12	46.00	51.00	18.19	22.62	6.62	.81
48	6"	E4665S-48	166	60.12	51.94	57.00	18.69	25.56	7.69	.81
	7"	E4765S-48	201	60.12	51.75	57.00	18.69	25.56	7.19	.81
54	6"	E4665S-54	192	66.12	59.19	63.00	19.25	29.25	8.19	.81
	7"	E4765S-54	231	66.12	59.00	63.00	19.25	29.25	7.69	.81
60	6"	E4665S-60	204	72.12	63.75	69.00	19.75	31.56	8.75	.81
	7"	E4765S-60	246	72.12	63.56	69.00	19.75	31.56	8.25	.81
66	6"	E4665S-66	219	78.12	69.69	75.00	20.31	34.56	9.25	.81
	7"	E4765S-66	264	78.12	69.50	75.00	20.31	34.56	8.75	.81
72	6"	E4665S-72	237	84.12	75.56	81.00	21.50	37.56	9.81	.94
	7"	E4765S-72	287	84.12	75.44	81.00	21.50	37.56	9.31	.94
78	6"	E4665S-78	252	90.12	81.50	87.00	22.06	40.56	10.31	.94
	7"	E4765S-78	306	90.12	81.31	87.00	22.06	40.56	9.81	.94
84	6"	E4665S-84	268	96.12	88.00	93.00	22.56	43.88	10.88	.94
	7"	E4765S-84	326	96.12	87.88	93.00	22.56	43.88	10.31	.94
90	6"	E4665S-90	283	102.12	93.94	99.00	23.12	46.88	11.38	.94
	7"	E4765S-90	345	102.12	93.75	99.00	23.12	46.88	10.88	.94
96	6"	E4665S-96	298	108.12	99.88	105.00	23.62	49.88	11.88	.94
	7"	E4765S-96	364	108.12	99.69	105.00	23.62	49.88	11.38	.94
102	6"	E4665S-102	332	114.12	105.75	111.00	24.19	52.88	12.44	.94
	7"	E4765S-102	402	114.12	105.56	111.00	24.19	52.88	11.94	.94

■ 10" bolt spacing recommended to permit adjustment.

\*\* For belt width + 15" mounting use next higher belt width.

# 15° V-Return Idlers

steel rolls, v-return

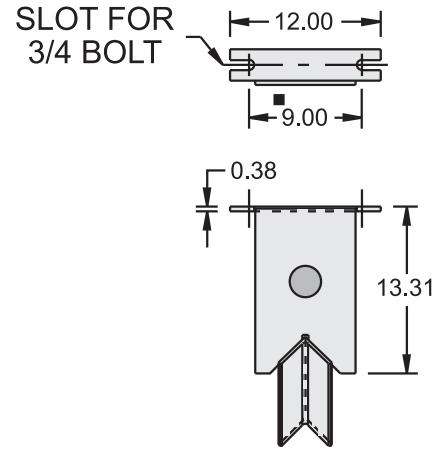
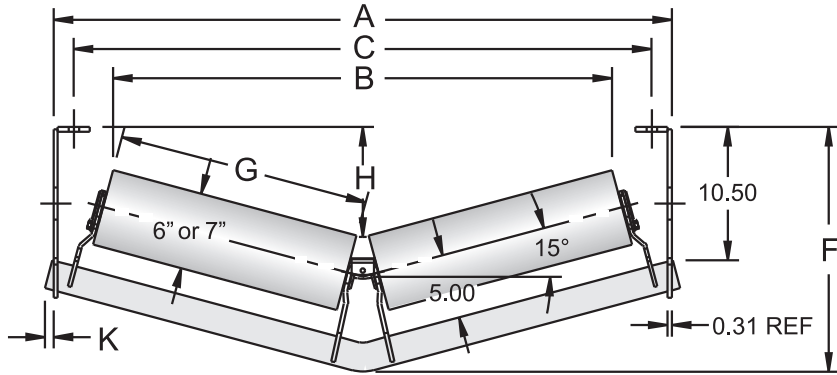

## CEMA E

** Belt width, inches	Dia.	Idler number	Idler weight, pounds	A	B	C	F	G	H	K
				Inches						
36	6"	E4666S-36	135	48.12	39.00	45.00	19.50	19.62	8.62	.94
	7"	E4766S-36	162	48.12	38.75	45.00	19.50	19.62	8.12	.94
42	6"	E4666S-42	154	54.12	44.75	51.00	20.69	22.62	9.44	1.06
	7"	E4766S-42	185	54.12	44.50	51.00	20.69	22.62	8.94	1.06
48	6"	E4666S-48	167	60.12	50.44	57.00	21.50	25.56	10.25	1.06
	7"	E4766S-48	202	60.12	50.19	57.00	21.50	25.56	9.75	1.06
54	6"	E4666S-54	193	66.12	57.56	63.00	22.31	29.25	11.06	1.06
	7"	E4766S-54	232	66.12	57.31	63.00	22.31	29.25	10.56	1.06
60	6"	E4666S-60	205	72.12	62.06	69.00	23.12	31.56	11.88	1.06
	7"	E4766S-60	248	72.12	61.81	69.00	23.12	31.56	11.38	1.06
66	6"	E4666S-66	220	78.12	67.88	75.00	23.88	34.56	12.69	1.06
	7"	E4766S-66	266	78.12	67.56	75.00	23.88	34.56	12.19	1.06
72	6"	E4666S-72	239	84.12	73.69	81.00	25.38	37.56	13.50	1.25
	7"	E4766S-72	289	84.12	73.38	81.00	25.38	37.56	13.00	1.25
78	6"	E4666S-78	254	90.12	79.44	87.00	26.19	40.56	14.31	1.25
	7"	E4766S-78	308	90.12	79.19	87.00	26.19	40.56	13.75	1.25
84	6"	E4666S-84	270	96.12	85.81	93.00	27.00	43.88	15.12	1.25
	7"	E4766S-84	328	96.12	85.56	93.00	27.00	43.88	14.56	1.25
90	6"	E4666S-90	285	102.12	91.62	99.00	27.81	46.88	15.88	1.25
	7"	E4766S-90	347	102.12	91.38	99.00	27.81	46.88	15.38	1.25
96	6"	E4666S-96	300	108.12	97.44	105.00	28.62	49.88	16.69	1.25
	7"	E4766S-96	366	108.12	97.19	105.00	28.62	49.88	16.19	1.25
102	6"	E4666S-102	335	114.12	103.25	111.00	29.44	52.88	17.50	1.25
	7"	E4766S-102	405	114.12	103.00	111.00	29.44	52.88	17.00	1.25

■ 10" bolt spacing recommended to permit adjustment.

\*\* For belt width + 15" mounting use next higher belt width.

# 10° V-Return Idlers

rubber tread rolls, v-return, massed ends

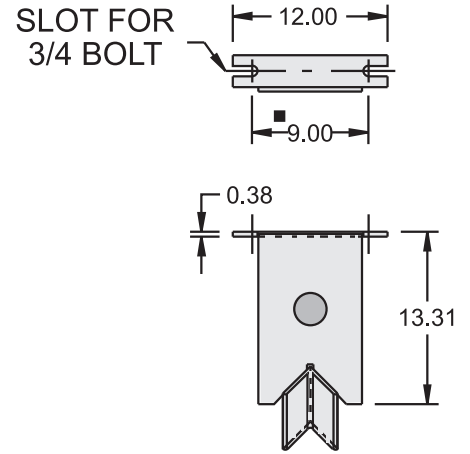
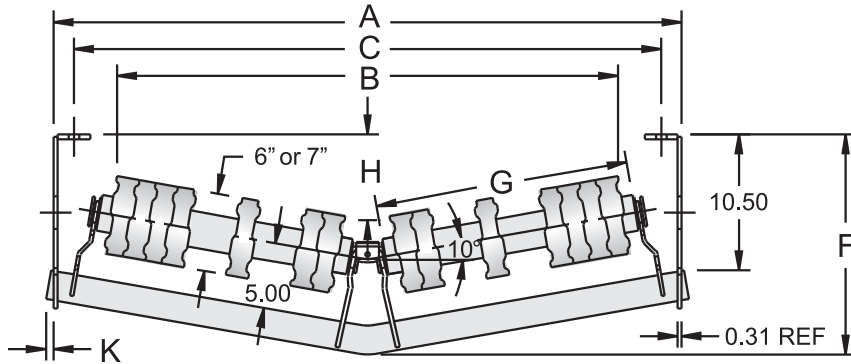

## CEMA E

** Belt width, inches	Dia.	Idler number	Idler weight, pounds	A	B	C	F	G	H	K
				Inches						
36	6"	E4668S-36	124	48.12	38.38	45.00	17.31	19.44	6.62	.75
	7"	E4768S-36	136	48.12	38.19	45.00	17.31	19.44	6.12	.75
42	6"	E4668S-42	144	54.12	44.25	51.00	18.19	22.44	7.12	.81
	7"	E4768S-42	159	54.12	44.06	51.00	18.19	22.44	6.62	.81
48	6"	E4668S-48	154	60.12	50.06	57.00	18.69	25.38	7.69	.81
	7"	E4768S-48	169	60.12	49.88	57.00	18.69	25.38	7.19	.81
54	6"	E4668S-54	180	66.12	57.38	63.00	19.25	29.06	8.19	.81
	7"	E4768S-54	198	66.12	57.19	63.00	19.25	29.06	7.69	.81
60	6"	E4668S-60	189	72.12	61.94	69.00	19.75	31.38	8.75	.81
	7"	E4768S-60	207	72.12	61.75	69.00	19.75	31.38	8.25	.81
66	6"	E4668S-66	199	78.12	67.81	75.00	20.31	34.38	9.25	.81
	7"	E4768S-66	217	78.12	67.69	75.00	20.31	34.38	8.75	.81
72	6"	E4668S-72	219	84.12	73.75	81.00	21.50	37.38	9.81	.94
	7"	E4768S-72	241	84.12	73.56	81.00	21.50	37.38	9.31	.94
78	6"	E4668S-78	230	90.12	79.62	87.00	22.06	40.38	10.31	.94
	7"	E4768S-78	251	90.12	79.50	87.00	22.06	40.38	9.81	.94
84	6"	E4668S-84	241	96.12	86.19	93.00	22.56	43.69	10.88	.94
	7"	E4768S-84	263	96.12	86.00	93.00	22.56	43.69	10.31	.94
90	6"	E4668S-90	258	102.12	92.06	99.00	23.12	46.69	11.38	.94
	7"	E4768S-90	283	102.12	91.88	99.00	23.12	46.69	10.88	.94
96	6"	E4668S-96	268	108.12	98.00	105.00	23.62	49.69	11.88	.94
	7"	E4768S-96	293	108.12	97.81	105.00	23.62	49.69	11.38	.94
102	6"	E4668S-102	299	114.12	103.88	111.00	24.19	52.69	12.44	.94
	7"	E4768S-102	323	114.12	103.69	111.00	24.19	52.69	11.94	.94

■ 10" bolt spacing recommended to permit adjustment.

\*\* For belt width + 15" mounting use next higher belt width.

# Ordering Replacement Rolls

Below are the part numbers to reference when ordering sealed replacement rolls for CEMA Series E. Frame is not included.

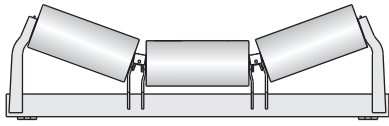

The following part numbers fit

**6" diameter steel troughing rolls for E4601S, E4602S, E4607S, E4608S, E4609S, E4611S, E4628S, E4632S and E4637S idlers**

**7" diameter steel troughing rolls for E4701S, E4702S, E4707S, E4708S, E4709S, E4711S, E4728S, E4732S and E4737S idlers**

## E4600 Replacement Rolls

### 6" diameter

Belt Width	Part Number
36	1730-455-A.S
42	1730-455-B.S
48	1730-455-C.S
54	1730-455-D.S
60	1730-455-E.S
72	1730-455-F.S
84	1730-455-G.S
96	1730-455-H.S

## E4700 Replacement Rolls

### 7" diameter

Belt Width	Part Number
36	1730-407-A.S
42	1730-407-B.S
48	1730-407-C.S
54	1730-407-D.S
60	1730-407-E.S
72	1730-407-F.S
84	1730-407-G.S
96	1730-407-H.S

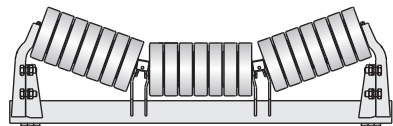

The following part numbers fit

**6" diameter rubber cushion troughing rolls for E4604S, E4623S and E4630S idlers**

**7" diameter rubber cushion troughing rolls for E4704S, E4723S and E4730S idlers**

## E4600 Replacement Rolls

### 6" diameter

Belt Width	Part Number
36	1730-933-A.S
42	1730-933-B.S
48	1730-933-C.S
54	1730-933-D.S
60	1730-933-E.S
66	1730-933-F.S
72	1730-933-G.S
78	1730-933-H.S

## E4700 Replacement Rolls

### 7" diameter

Belt Width	Part Number
36	1730-312-A.S
42	1730-312-B.S
48	1730-312-C.S
54	1730-312-D.S
60	1730-312-E.S
66	1730-312-F.S
72	1730-312-G.S
78	1730-312-H.S

# Ordering Replacement Rolls

Below are the part numbers to reference when ordering sealed replacement rolls for CEMA Series E. Frame is not included.



The following part numbers fit

- 6" diameter steel return rolls for E4617S and E4620S idlers**
- 7" diameter steel return rolls for E4717S and E4720S idlers**

## E4600 Replacement Rolls

### 6" diameter

Belt Width	Part Number
36	1730-456-A.S
42	1730-456-B.S
48	1730-456-C.S
54	1730-456-D.S
60	1730-455-E.S
72	1730-456-F.S
-	-
-	-

## E4700 Replacement Rolls

### 7" diameter

Belt Width	Part Number
36	1730-423-A.S
42	1730-423-B.S
48	1730-423-C.S
54	1730-423-D.S
60	1730-423-E.S
72	1730-423-F.S
84	1730-423-K.S
96	1730-423-M.S



The following part numbers fit

- 6" diameter rubber cushion rolls for E4615S idlers**
- 7" diameter rubber cushion rolls for E4715S idlers**

## E4600 Replacement Rolls

### 6" diameter

Belt Width	Part Number
36	1730-934-A.S
42	1730-934-B.S
48	1730-934-C.S
54	1730-934-D.S
60	1730-934-E.S
72	1730-934-F.S
84	1730-934-L.S
96	1730-934-M.S

## E4700 Replacement Rolls

### 7" diameter

Belt Width	Part Number
36	1730-324-A.S
42	1730-324-B.S
48	1730-324-C.S
54	1730-324-D.S
60	1730-324-E.S
72	1730-324-F.S
84	1730-324-L.S
96	1730-324-M.S

# Ordering Replacement Rolls

Below are the part numbers to reference when ordering sealed replacement rolls for CEMA Series E. Frame is not included.

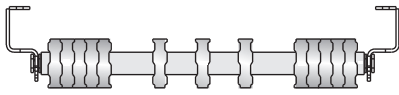

The following part numbers fit

**6" diameter rubber tread return rolls for E4618S idlers**

**7" diameter rubber tread return rolls for E4718S idlers**

## E4600 Replacement Rolls

### 6" diameter

Belt Width	Part Number
36	1730-314-A.S
42	1730-314-B.S
48	1730-314-C.S
54	1730-314-D.S
60	1730-314-E.S
72	1730-314-F.S
84	1730-314-G.S
96	1730-314-H.S

## E4700 Replacement Rolls

### 7" diameter

Belt Width	Part Number
36	1730-491-A.S
42	1730-491-B.S
48	1730-491-C.S
54	1730-491-D.S
60	1730-491-E.S
72	1730-491-F.S
84	1730-491-G.S
96	1730-491-H.S

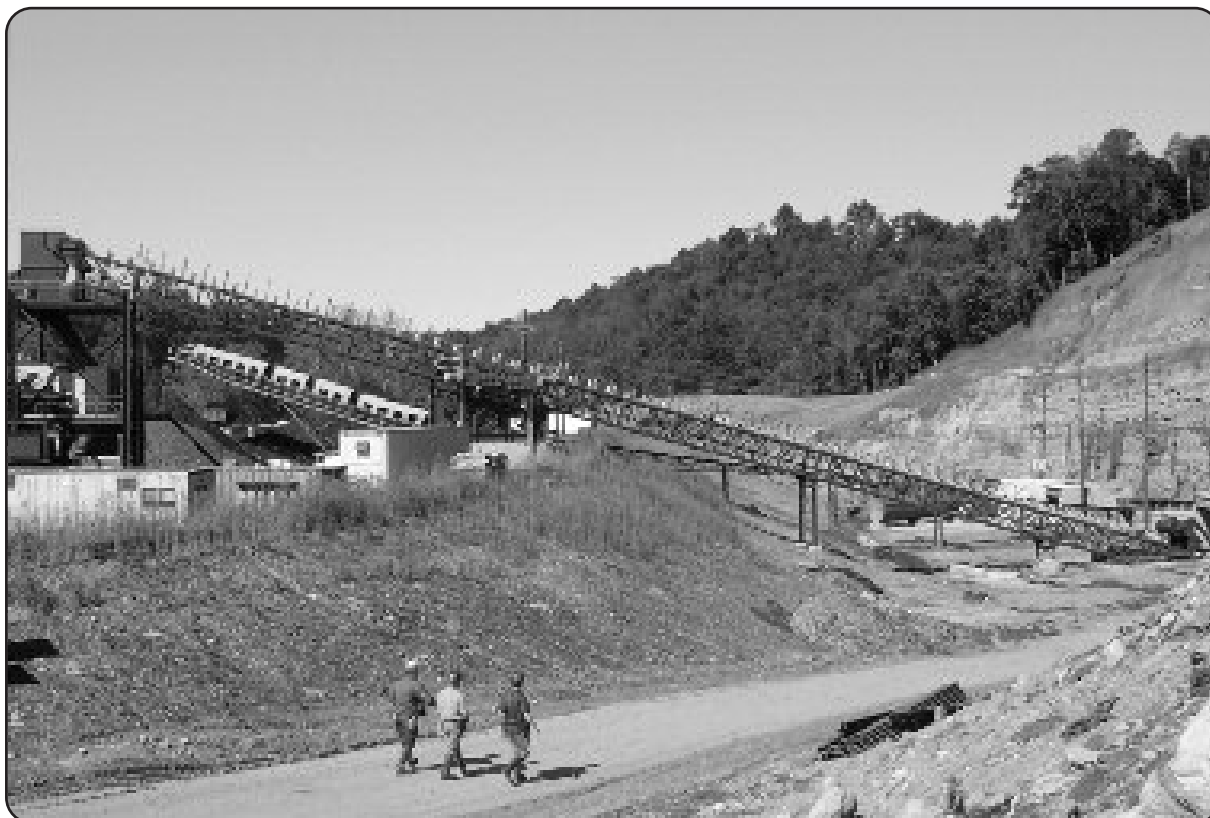

# Introducing Composite Idler Rolls

- Combats roll degradation typically found in corrosive and abrasive environments
- Longer lasting rolls reduces conveyor downtime
- Lighter weight rolls – “Field Friendly” for maintenance and installation personnel
- Prolongs belt life by reducing material build-up



Dimensional specifications match our CEMA C, D and E series steel products.

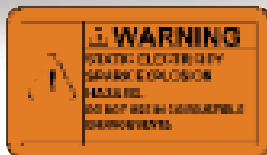

## Composite Idler Roll Advantages

- Excellent Strength
- Lighter Weight
- Superior Toughness
- High Corrosion Resistance
- High Abrasion Resistance
- Reduced Material Build-Up
- Low Coefficient of Thermal Expansion
- Environmentally Friendly



*Ideal for replacement of steel rolls in corrosive environments.*



# Composite Rolls

## Technical Data

---

### What are composite idler rolls?

- Syntron Material Handling introduces a revolutionary new idler roll made with state-of-the-art glass reinforced polyurethane.
- This tubing is a composite material consisting of layers of high quality glass fabric saturated with a two part thermoset polyurethane resin.
- Syntron Material Handling offers a 5" and a 6" diameter x 1/4" wall tubing size suitable for CEMA C, D and E roll applications (Syntron Material Handling C/D3500, C/D3600 & E4600 Series).
- Roll lengths are available for troughing, return, picking and V-return idlers with belt widths ranging from 18" to 72".
- Polyurethane pultruded composite tubing offers excellent mechanical properties similar to steel and superior to many traditional plastic resin roll products. The recommended operating temperature range is -40°F to +200°F.
- Syntron Material Handling composite rolls are extremely versatile and are suitable for many material handling applications\*.
- Standard color: Traditional "Syntron Material Handling Orange"

\*Currently not suitable in combustible environments, where possible static charge can cause an explosion hazard.

### Features/Benefits

- **Excellent Strength**  
Comparable tensile and flexural strength (lengthwise) to steel and aluminum. High strength-to-weight ratio.
- **Lighter Weight**  
Material verses material: 75% lighter than steel and 30% lighter than aluminum. Approximately 50% lighter than traditional steel rolls. Easier installation, "Field Friendly" for maintenance and installation personnel, energy savings, and reduced noise.
- **Superior Toughness**  
This glass fabric distributes loads to prevent surface damage. No permanent deformities. High impact strength. Crack resistant.
- **High Corrosion Resistance**  
Superior resistance to a broad range of chemicals. Excellent in acid, alkali and salt spray environments. Low water absorption. Protective Polyurethane topcoat is suggested if exposed to UV rays during a long term storage.
- **High Abrasion Resistance**  
Superior wear resistance to traditional thermoplastic resin rolls, resulting in longer shell life, longer belt life, and less maintenance.
- **Reduced Material Build-Up**  
Polyurethane resin resists material build-up on the surface of the roll, thereby prolonging belt life.
- **Low Thermal Coefficient of Expansion**  
Low coefficient of thermal expansion, comparable to steel, reducing differential expansion between shell, shaft, and the pressed head.
- **Environmentally Friendly**  
Self extinguishing when exposed to flame in a horizontal position. Low carbon footprint compared to thermoplastic rolls. VOC Free.

*Is corrosion eating away your profits?*



# Composite Rolls

Below are the part numbers to reference when ordering replacement rolls for CEMA Series E. Frame is not included.

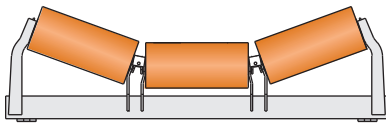

The following part numbers fit

**6" diameter composite troughing rolls for E4601C, E4602C, E4606C, E4607C, E4608C, E4609C, E4611C, E4628C, E4632C and E4637C idlers**

## E4600 Replacement Rolls

**6" diameter**

Belt Width	Part Number
36	5269-344-E
42	5269-344-F
48	5269-344-G
54	5269-344-H
60	5269-344-J
72	5269-344-L
84	5269-344-N
96	5269-344-R



The following part numbers fit

**6" diameter composite return rolls for E4613C, E4617C, E4620C and 4626C idlers**

## E4600 Replacement Rolls

**6" diameter**

Belt Width	Part Number
36	5269-344-AE
42	5269-344-AF
48	5269-344-AG
54	5269-344-AH
60	5269-344-AJ
66	5269-344-AK
72	5269-344-AL
78	5269-344-AM

# Link-Belt® ES Series™ Idler Rolls

Introducing the ES Series Idler Rolls from Syntron Material Handling, specifically designed for extreme service in the harsh environment of oil sands extraction. Link-Belt ES Series Idlers feature a patented seal design that offers unique and superior benefits to competitor rolls.

## Roll Features

- **Higher Load Ratings with Proven Seal Geometry**

Inefficient use of available space with the bearing housing can lead to load rating deficiencies. The deeper inside the roll the bearing is located, the larger the moment arm, which in turn, results in increased shaft deflection for a given load. Syntron Material Handling's patented seal design utilizes dual function components that make more efficient use of the available space inside the bearing housings.

**This translates into higher load ratings with proven seal geometry.**

- **Longer Roll Life**

Every aspect of the design and manufacturing contributes to the superiority of Syntron Material Handling ES Series Idler Rolls. Using high-quality materials and state-of-the-art manufacturing methods, each roll is built with minimal endplay. Syntron Material Handling's advanced, pressed head design yields superior circular run out values by eliminating warping caused by welding. The precision-machined rugged cast bearing housings are designed to provide maximum rigidity to reduce bearing misalignment.

**These features result in longer roll life.**

- **Flexible, Cost-Effective Rebuild Options**

Industry standard roll design features a thin head that is welded directly to the end of the expensive, rubber coated shell. During a seal or bearing failure, this thin, welded head is often damaged and consequently, the entire roll must be replaced. Syntron Material Handling's roll features a pressed head that can be removed from the shell to permit replacement of all components while reusing the same shell, maximizing the life of the rebuilt roll at greatly reduced costs.

**Syntron Material Handling pressed heads can be used to rebuild competitor rolls.**

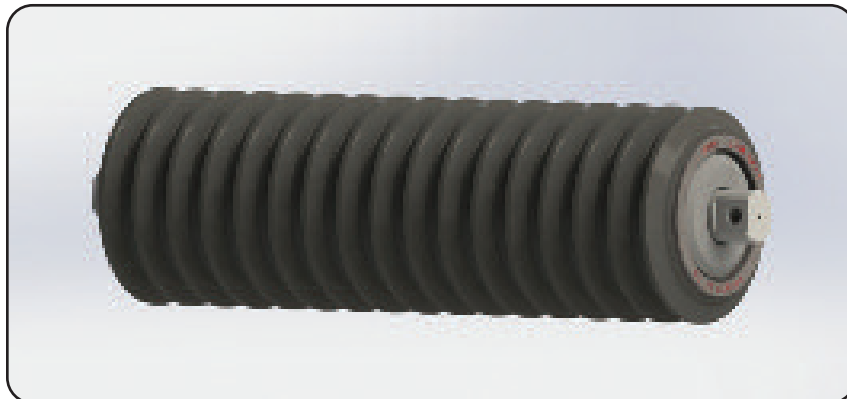

## Revolutionary Seal Design

In developing the new ES Series idler rolls, Syntron Material Handling's research and development team considered all aspects of seal technology, optimizing each component for maximum benefit. Their patented seal design maximizes sealing effectiveness and minimizes shaft deflection.

Syntron Material Handling's new seal utilizes both contact seal (to exclude liquids) and labyrinth seal (to exclude solid contaminants) technologies. In contrast to typical competitor designs, Syntron Material Handling takes full advantage of the strengths of both types of seals, resulting in a revolutionary new arrangement.

The outer labyrinth seal element has a galvanized steel shield which protects the internal seal components from damage. This shield is constructed to withstand harsh environmental abrasions and abuse and includes a low-friction, outer face contact weather seal to prevent water washout of grease filled labyrinths.

The inner labyrinth/dual lip contact seal element is located deeper inside the roller which protects it from the outside environment. It rides directly against the shaft near the inner diameter of the bearing. This ensures full and constant contact, longer wear life, less drag and maximum sealing.

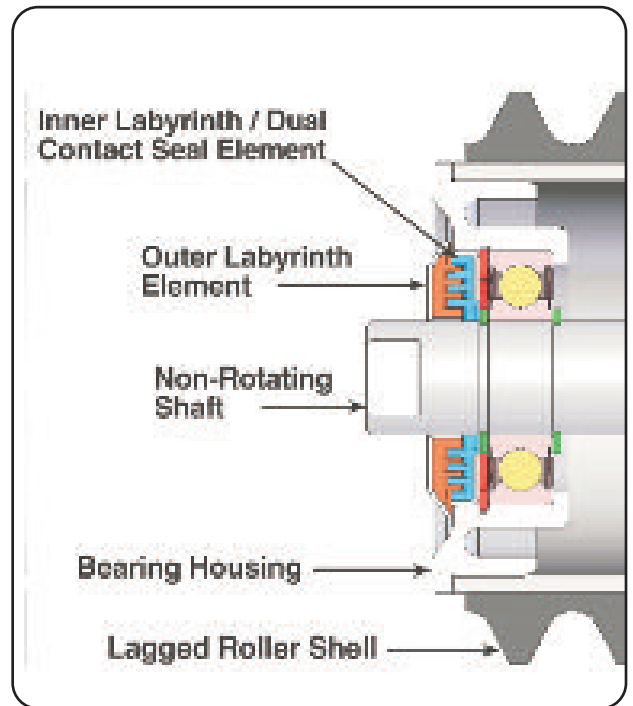

## Bearing Location and Improved Load Rating

The load rating of an idler roll is largely dependent on the load rating of the bearings used in the rolls. The location of the bearings with respect to the shaft supports also affects the load rating and the expected life of the roll. As illustrated in Figure 2, shaft deflection is a result of bearing location. Under high loads, the shaft behaves as a flexible member. Shaft deflection causes unwanted friction inside the bearings and reduces bearing life. In Syntron Material Handling's new design, the bearings are placed closer to the support, reducing the length of the shaft extension from the bearing to the support by approximately 30 percent, thereby increasing the load rating. Efficient bearing placement also minimizes shaft deflection due to load, and thus increases bearing life.

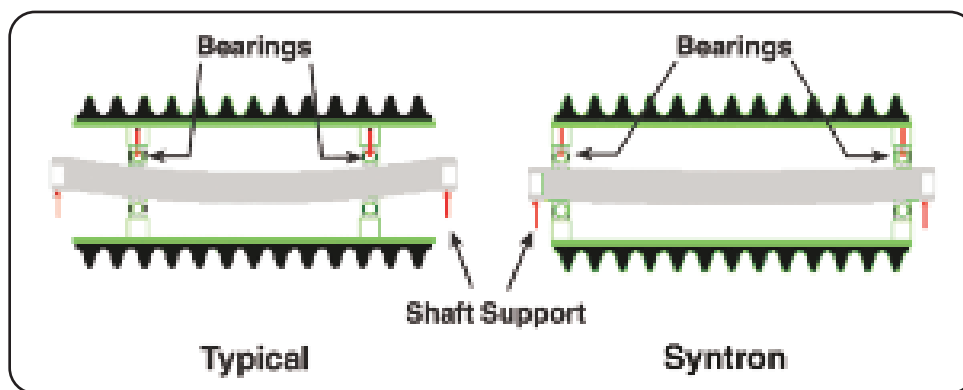
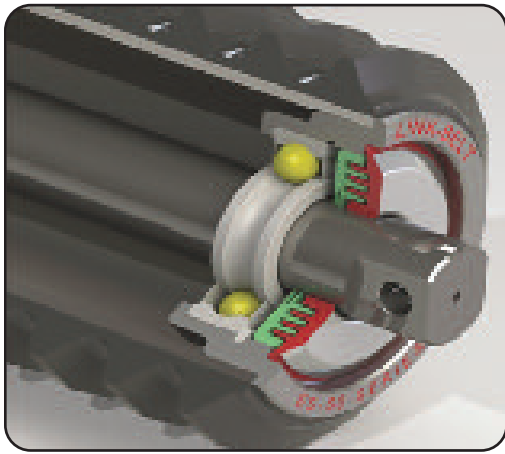

Figure 2: Shaft Deflection as a Result of Bearing Placement

## Press-Fit Technology

Syntron Material Handling engineers developed press-fit technology, an interference-fit bearing housing (head) that presses into the shell, eliminating welding and the shell distortion caused by heat generated during welding. The internal areas are precision machined for accurate bearing/shaft alignment to provide desired interference values between the bearing housing and the shell.



Precision-machined ductile-iron bearing housings provide highly controlled bearing bore dimensions, excellent circular runout and excellent alignment through the roll from end to end. In addition, the high concentricity of the machined bearing housing is transferred to the shell and actually improves the roundness of the shell.

Press fit technology has been tried and proven in some of the most demanding applications and harshest environments in the industry, including rock quarries, construction and underground mining. Press-fit technology has been incorporated into the design of the Link-Belt ES Series rolls.

With press-fit technology, rebuilding ES Series rolls becomes easy and economical. The bearing housing can be pressed out and inspected for damage to components. Individual components can be easily replaced, or the entire bearing housing can be replaced. Either way, the shell can be reused. And Syntron Material Handling pressed heads can be used in competitor rolls.

## It all adds up...

The most advanced and innovative technologies have gone into the development of Link-Belt ES Series Idler Rolls. Each individual component represents an advance in available technology:

- Patented seal design for higher load ratings and maximum sealing effectiveness
- Pressed head technology for superior and flexible rebuild options
- Efficient bearing placement for minimized shaft deflection and longer bearing life

Together, these features add up to outstanding performance, quality and value. Link-Belt ES Series Idler Rolls from Syntron Material Handling – specifically designed and engineered for extreme service in the harsh environment of oil sands extraction.

ES Series Idler Rolls are available in a range of standard models and sizes (refer to the chart). Other models and sizes are available by request and may be custom engineered to meet application requirements.

Models	72" Trough	72" Impact	72" Return	84" Trough	84" Impact	84" Return
40 mm Bearings	•	•	•	•	•	•
50 mm Bearings	•	•	•	•	•	•
60 mm Bearings	•	•	•	•	•	•

# Link-Belt® EZ-Trip™ Idler Frames

- Heavy-duty, tubular construction
- Reduced weight assembly for ease of installation and reduced costs
- Polymeric powder coated frame affords superior corrosion protection
- Sealed-for-life design protects against mechanical seizure in cold, harsh environments

The Link-Belt EZ-Trip Idler is specifically built for the field-proven Link-Belt ES Series Idler Rolls.

## Frame Features

- **Simple Assembly for Ease of Operation**

The unique Link-Belt EZ-Trip Idler is easy to install and operate – simply pull the pin and strike the end rod with a hammer.

- **Heavy-Duty, Tubular Construction**

Fabricated with heavy-duty tough steel, the frame members are welded to AWS D1.1 specifications to ensure superior strength and dimensional accuracy. Featuring a two-piece construction, the independent base frame maintains overall alignment of the assembly. In addition, there is minimal “play” in the frame when in a locked state. The rugged frame’s tubular construction also minimizes the potential for material buildup.



## Frame Features (cont.)

- **Corrosion Resistance**

The E-Z Trip Idler features stainless steel pull pins with stainless lanyard tabs and corrosion resistant “strike” ends for excellent corrosion protection. Plus, a superior polymeric protective powder coating is applied to stand up to harsh environments.

- **“Sealed-for-Life” Design to Prevent Seizing Up**

The E-Z Trip Idler features a factory lubricated design to eliminate any need for re-lubrication, thus lowering total maintenance costs. Each “sealed-for-life” end is filled with low temperature grease. Nitrile rubber seals are employed to protect the frame pivots on each end and a Nitrile rubber oil-seal protects around the outside of the “strike rods.” Fiberglass reinforced nylon bushings provide low friction movement for both the frame pivot and the strike rod sliding contact.

You just can't find better performance than the Link-Belt EZ-Trip Idler.

For more information contact our Applications Specialist at 1-800-356-4899.

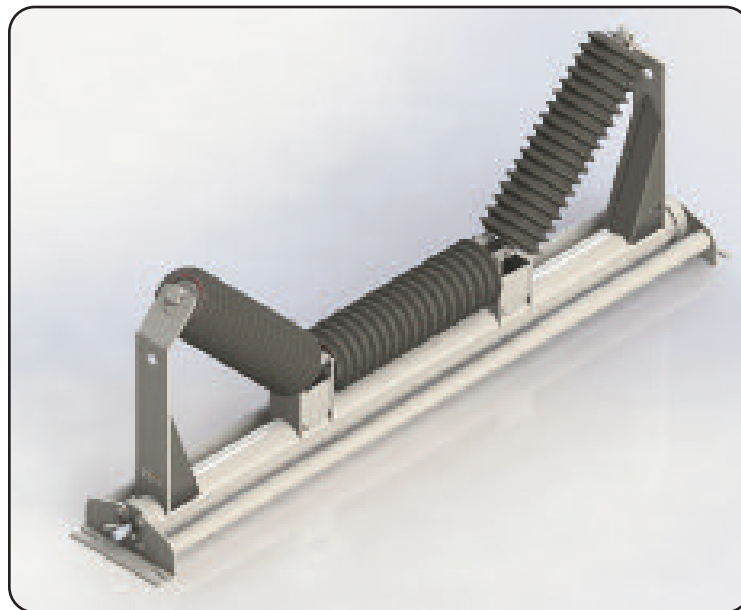

**Upright**



**Tripped**

# ES-Series™ Product Line



5-Roll Impact Catenary  
(rubber lagged)

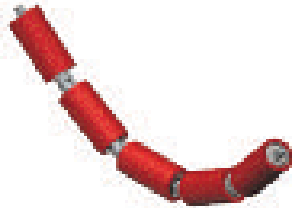

5-Roll Dissipator Catenary  
(urethane lagged)



3-Roll Carrying Catenary



2-Roll V-Return Catenary



3-Roll Carrying Idler "Upright"



Flat Return Idler



2-Roll V-Return Idler

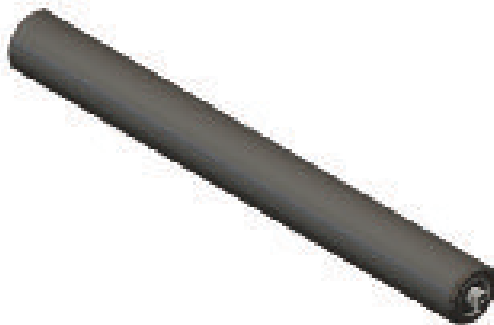

Pressure Roller

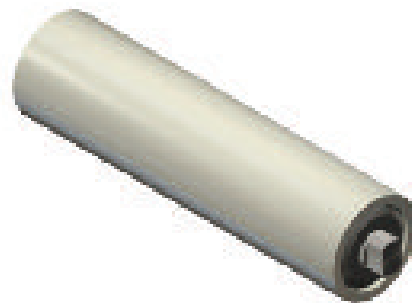

Slide Guide Roller



# CEMA Series F5000 Idlers

## Bearings

- Precision tapered roller bearings; LM25500 with 1- $\frac{3}{4}$ " bore
- Bearings/shaft are designed to accommodate bearing misalignment under fully rated loads
- L10 bearing life > 60,000 hrs @ 500 rpm, exceeds load ratings of 6310 ball bearing products

## Frames

- Inverted angle frame base with slotted foot straps to ensure quick, easy mounting and alignment
- Heavy-duty, die-formed, steel end brackets are contoured for generous clearance to safeguard against spilled materials becoming jammed and impeding the rotation of the rollers
- All idler frames are welded in accordance with AWS D1.1 specifications for structural welds

## Seal

- Rubber triple lip contact seal paired with a zinc plated, machined steel deflector nut with integrated labyrinth seal for robust, redundant sealing capability
- Seal works well in dusty conditions and wash down environments

## Coatings

- Frames and rolls are powder-coated (see page 155 for details)
- Assembly hardware is electro-zinc plated

## CEMA

- Idlers meet or exceed CEMA requirements for rugged, continuous material handling
- Multiple belt widths and models available to meet your needs

## Roll Thickness

- 7" diameter = 0.250"
- 8" diameter = 0.250"
- 6" diameter rolls are available

## Testing Capabilities

- Load rating
- Seals
- Roll concentricity
- Roll resistance
- Roll imbalance
- Water resistance

One of the following letter suffixes may sometimes be necessary to complete an idler description:

- P** - Polyethylene rolls
- R** - Rubber lagged impact or rubber tread rolls
- RC** - Rubber lagged impact center roll
- W** - Scale idler
- U** - Urethane coated or lagged rolls
- GAL** - Galvanized frame

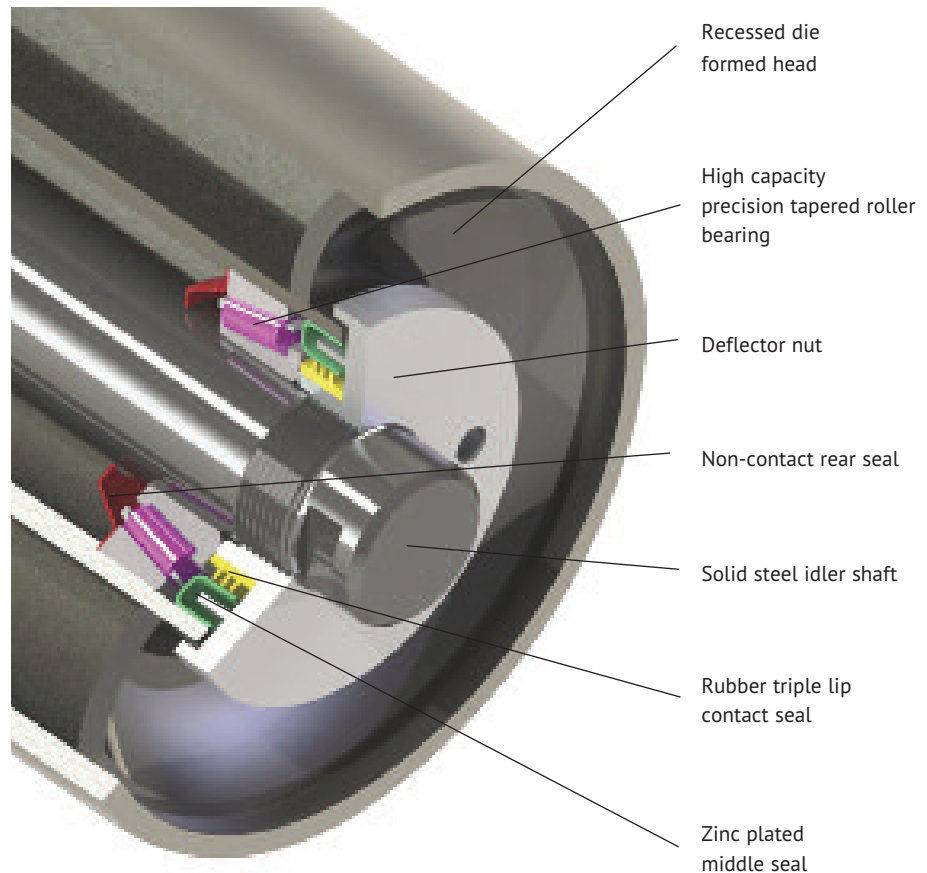

# Idlers of Every Type to Meet Your Specific Needs

Series F5000		CEMA F
	belt width, inches	roll dia., inches
<b>Troughed Belt Idlers</b>		
steel rolls 20°-35°-45°	48-120	7-8
<b>Return Idlers</b>		
steel rolls	48-120	7-8

## Carrying Idler Types

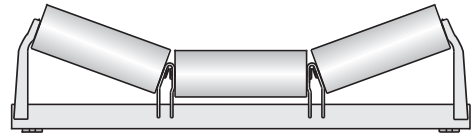

Troughed belt idlers for general carrying service are available with trough angles of 20°, 35°, and 45°.

models: F5701, F5801, F5702, F5802, F5728, F5828

## CEMA Classification

Series No.	Roll Dia., in.	Basic Idler Nomenclature	CEMA Class	
			Old	New
F5000	7	F5700	none	F7
F5000	8	F5800	none	F8

## Return Idler Types



Return belt idlers carry the empty belt on the return run.

models: F5717, F5817

F5000 IDLER LOAD RATINGS				
Belt Width (in.)	Trough		Return	
	CEMA (lbs)	F5000 (lbs)	CEMA (lbs)	F5000 (lbs)
48	-	3800	-	2400
54	-	3800	-	2300
60	3000	3800	1500	2200
72	3000	3800	1200	2000
84	3000	3800	900	2100
96	2800	3800	600	1900
108	-	3800	-	1700
120	-	3800	-	1600



CAUTION: Link-Belt Conveyor idlers must be installed, operated and maintained in accordance with accompanying Syntron Material Handling Service Instructions. Failure to follow these instructions can result in serious personal injury, property damage or both.

Syntron Material Handling Service Instructions are available for download at [www.syntronmh.com](http://www.syntronmh.com).

For 10,000 series idlers consult our factory.

# 20° Troughed Belt Idlers, Equal Length Rolls

steel rolls

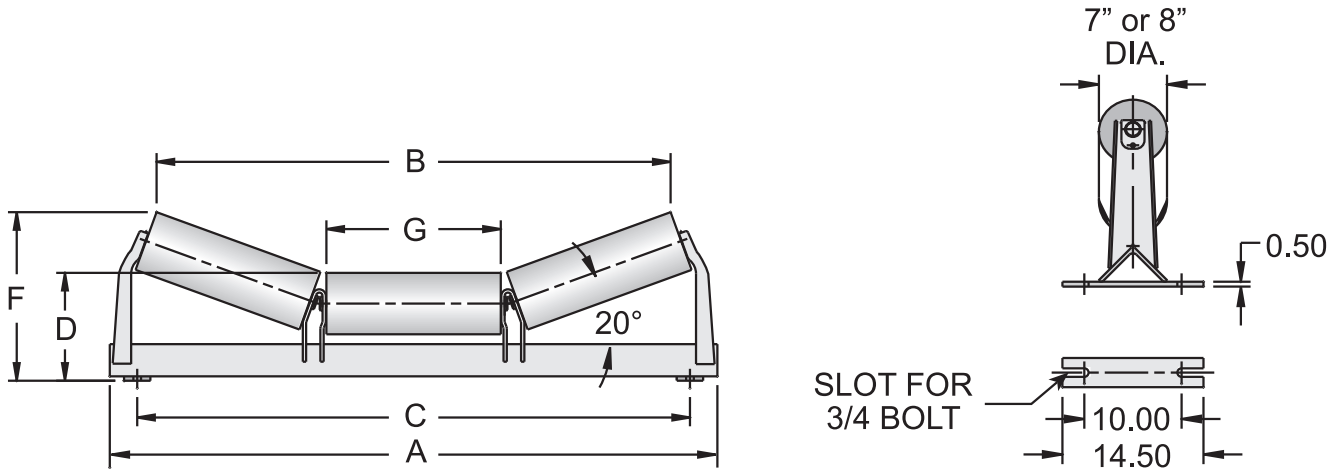

## CEMA F

Belt width, inches	Dia.	Idler number	Idler weight, pounds	A	B	C	D	F	G
				Inches					
48	7"	F5701-48	279	63.00	52.44	57.00	12.31	18.50	17.75
	8"	F5801-48	293	63.00	51.81	57.00	12.81	18.88	17.44
54	7"	F5701-54	306	69.25	58.56	63.00	12.31	19.19	19.88
	8"	F5801-54	321	69.25	57.94	63.00	12.81	19.62	19.56
60	7"	F5701-60	332	76.00	64.69	69.00	12.31	19.94	22.00
	8"	F5801-60	349	76.00	64.06	69.00	12.81	20.38	21.69
66	7"	F5701-66	384	82.00	70.81	75.00	12.31	20.69	24.12
	8"	F5801-66	403	82.00	70.19	75.00	12.81	21.12	23.81
72	7"	F5701-72	412	88.00	76.94	81.00	12.31	21.44	26.25
	8"	F5801-72	432	88.00	76.31	81.00	12.81	21.88	25.94
78	7"	F5701-78	440	94.00	83.06	87.00	12.31	22.19	28.38
	8"	F5801-78	461	94.00	82.44	87.00	12.81	22.56	28.06
84	7"	F5701-84	457	100.00	89.19	93.00	13.00	23.56	30.50
	8"	F5801-84	479	100.00	88.56	93.00	13.50	23.94	30.19
96	7"	F5701-96	512	112.50	101.44	105.00	13.00	25.00	34.75
	8"	F5801-96	537	112.50	100.81	105.00	13.50	25.44	34.44
108	7"	F5701-108	616	125.00	113.69	117.00	13.06	26.50	39.00
	8"	F5801-108	644	125.00	113.00	117.00	13.56	26.94	38.69
120	7"	F5701-120	676	137.50	125.88	129.00	13.06	27.94	43.25
	8"	F5801-120	707	137.50	125.25	129.00	13.56	28.38	42.94

# 35° Troughed Belt Idlers, Equal Length Rolls

steel rolls

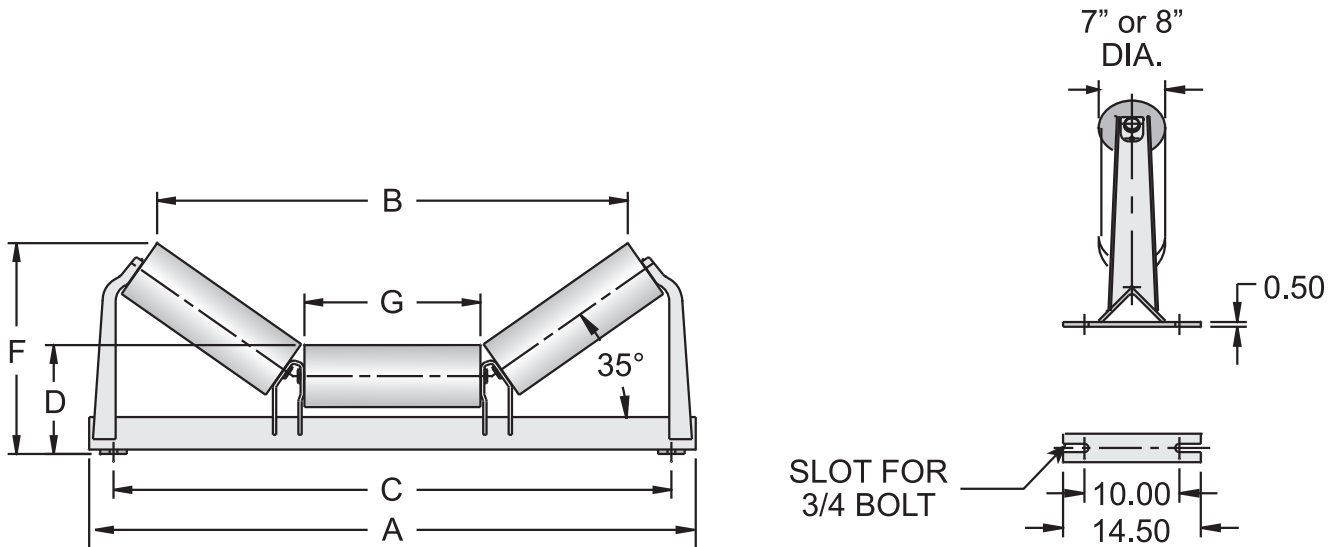

## CEMA F

Belt width, inches	Dia.	Idler number	Idler weight, pounds	A	B	C	D	F	G
				Inches					
48	7"	F5728-48	287	63.00	47.56	57.00	12.31	22.62	17.75
	8"	F5828-48	301	63.00	46.69	57.00	12.81	22.94	17.44
54	7"	F5728-54	313	68.50	53.12	63.00	12.31	23.81	19.88
	8"	F5828-54	328	68.50	52.31	63.00	12.81	24.12	19.56
60	7"	F5728-60	339	74.25	58.75	69.00	12.31	25.00	22.00
	8"	F5828-60	356	74.25	57.94	69.00	12.81	25.38	21.69
66	7"	F5728-66	392	80.25	64.38	75.00	12.31	26.31	24.12
	8"	F5828-66	410	80.25	63.56	75.00	12.81	26.62	23.81
72	7"	F5728-72	420	86.00	70.00	81.00	12.31	27.50	26.25
	8"	F5828-72	440	86.00	69.12	81.00	12.81	27.81	25.94
78	7"	F5728-78	449	92.00	75.56	87.00	12.31	28.75	28.38
	8"	F5828-78	470	92.00	74.75	87.00	12.81	29.06	28.06
84	7"	F5728-84	466	97.50	81.19	93.00	13.00	30.62	30.50
	8"	F5828-84	489	97.50	80.38	93.00	13.50	30.94	30.19
96	7"	F5728-96	523	109.50	92.38	105.00	13.00	33.06	34.75
	8"	F5828-96	548	109.50	91.56	105.00	13.50	33.38	34.44
108	7"	F5728-108	626	121.00	103.62	117.00	13.06	35.56	39.00
	8"	F5828-108	654	121.00	102.81	117.00	13.56	35.88	38.69
120	7"	F5728-120	686	132.00	114.81	129.00	13.06	37.94	43.25
	8"	F5828-120	717	132.00	114.00	129.00	13.56	38.31	42.94

# 45°

## Troughed Belt Idlers, Equal Length Rolls

steel rolls

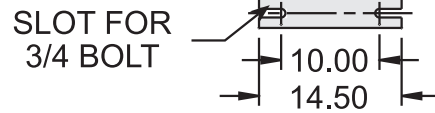
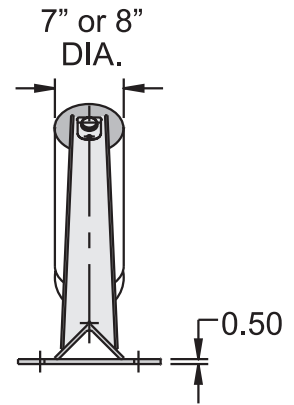
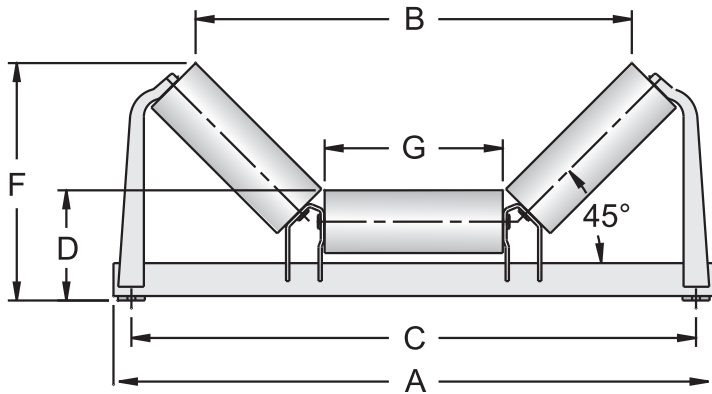

## CEMA F

Belt width, inches	Dia.	Idler number	Idler weight, pounds	A	B	C	D	F	G
				Inches					
48	7"	F5702-48	290	61.00	43.56	57.00	12.31	25.00	17.75
	8"	F5802-48	304	61.00	42.62	57.00	12.81	25.25	17.44
54	7"	F5702-54	317	67.00	48.69	63.00	12.31	26.50	19.88
	8"	F5802-54	333	67.00	47.75	63.00	12.81	26.75	19.56
60	7"	F5702-60	344	72.00	53.81	69.00	12.31	28.00	22.00
	8"	F5802-60	360	72.00	52.88	69.00	12.81	28.25	21.69
66	7"	F5702-66	396	78.00	58.94	75.00	12.31	29.56	24.12
	8"	F5802-66	414	78.00	58.00	75.00	12.81	29.81	23.81
72	7"	F5702-72	426	84.00	64.06	81.00	12.31	31.06	26.25
	8"	F5802-72	445	84.00	63.12	81.00	12.81	31.31	25.94
78	7"	F5702-78	455	90.00	69.19	87.00	12.31	32.56	28.38
	8"	F5802-78	476	90.00	68.25	87.00	12.81	32.81	28.06
84	7"	F5702-84	474	96.00	74.31	93.00	13.00	34.69	30.50
	8"	F5802-84	496	96.00	73.38	93.00	13.50	34.94	30.19
96	7"	F5702-96	532	108.00	84.62	105.00	13.00	37.69	34.75
	8"	F5802-96	557	108.00	83.69	105.00	13.50	37.94	34.44
108	7"	F5702-108	637	120.00	94.88	117.00	13.06	40.75	39.00
	8"	F5802-108	665	120.00	93.94	117.00	13.56	41.00	38.69
120	7"	F5702-120	700	132.00	105.12	129.00	13.06	43.75	43.25
	8"	F5802-120	731	132.00	104.19	129.00	13.56	44.00	42.94

# Return Belt Idlers

steel rolls

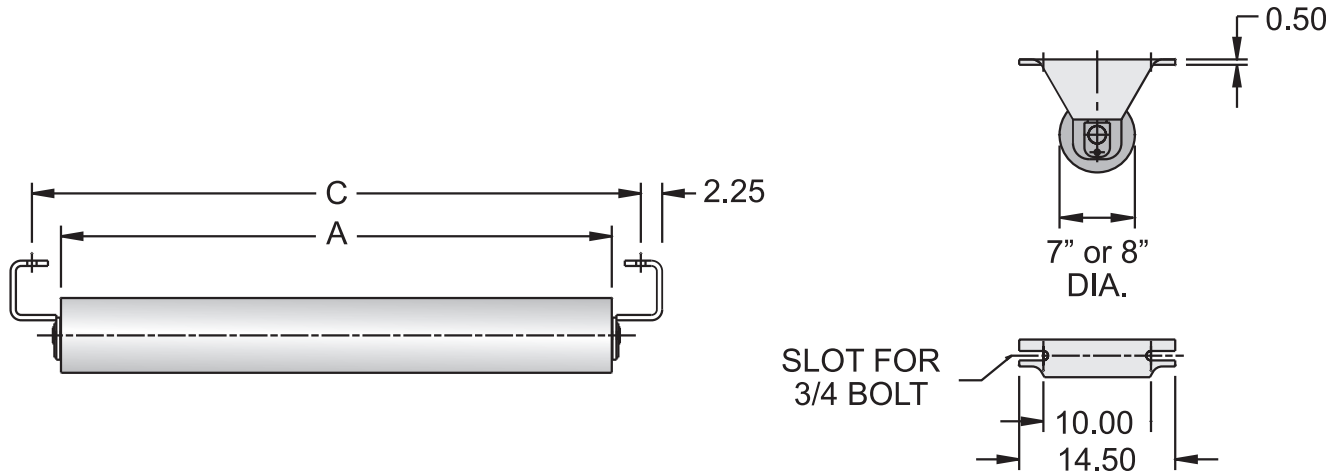

## CEMA F

Belt width, inches	Dia.	Idler number	Idler weight, pounds	Inches	
				A	C
48	7"	F5717-48	189	51.56	57.00
	8"	F5817-48	201	51.25	57.00
54	7"	F5717-54	206	57.56	63.00
	8"	F5817-54	220	57.25	63.00
60	7"	F5717-60	224	63.56	69.00
	8"	F5817-60	239	69.25	69.00
66	7"	F5717-66	241	69.56	75.00
	8"	F5817-66	258	69.25	75.00
72	7"	F5717-72	259	75.56	81.00
	8"	F5817-72	276	75.25	81.00
78	7"	F5717-78	277	81.56	87.00
	8"	F5817-78	295	81.25	87.00
84	7"	F5717-84	294	87.56	93.00
	8"	F5817-84	314	87.25	93.00
96	7"	F5717-96	329	99.56	105.00
	8"	F5817-96	352	99.25	105.00
108	7"	F5717-108	365	111.56	117.00
	8"	F5817-108	390	111.25	117.00
120	7"	F5717-120	400	123.56	129.00
	8"	F5817-120	428	123.25	129.00

## Series 40,000 and 70,000 Catenary Belt Conveyor Idlers

Link-Belt Series 40,000 and 70,000 Catenary Belt Conveyor Idlers combine the proven capabilities of the Link-Belt roll design with the benefits of a catenary suspension to form a smooth natural trough and ideal load conveying surface.

Series 40,000 and 70,000 Catenary Idlers are manufactured to withstand heavy impact at loading and transfer points as required by wide belts through 96-inch width. Superior performance and proven dependability are the result of rugged roll construction, exclusive labyrinth seal design and high-capacity “sealed for life” tapered roller bearings.

Especially suited to loading areas or transfer points in reclaiming installations where high impact loads must be absorbed, these catenary idlers have the design and built-in ability to adjust under varying loading conditions.

The Series 40,000 exclusive outboard seal effectively protects bearings three ways... a triple lip nitrile rubber primary seal... triple labyrinth... and grease-filled clearances. This design makes the idlers impervious to moisture and contaminants, extending idler life.

The complete line of Link-Belt Series 40,000 Catenary Belt Conveyor Idlers includes 35° 3-roll Troughing Idlers, 55° 5-roll Impact Idlers, and 10° and 15° 2-roll V-Return Idlers. V-Return Idlers are supplied with steel rolls. This full range of idlers provides the design engineer with components required to select an efficient material conveying system.

All Series 40,000 idlers are available for belt widths from 36 up to 96-inches and can be supplied with either 6- or 7-inch diameter rolls. Prior to shipping, rolls are protected by a baked on polymeric powder coating.

When load carrying requirements exceed standard limitations, the Series 70,000 Catenary Idler provides more than double the capacity of the Series 40,000 Belt Conveyor Idler.

Catenary Chain Connecting Devices are an economical and effective means for suspension of 3-roll Troughing Idlers and 2-roll V-Return Idlers. A bar link arrangement for 5-roll Impact Idlers is also available. There are various other Connecting Devices available for the Link-Belt Catenary Idlers which allow the conveyor designer complete freedom in choice of support structures. Details can be furnished upon request. Quick Disconnect Devices for Syntron Material Handling Catenary Idlers can also be provided, which permit operators to drop an idler out of service without stopping the conveyor.

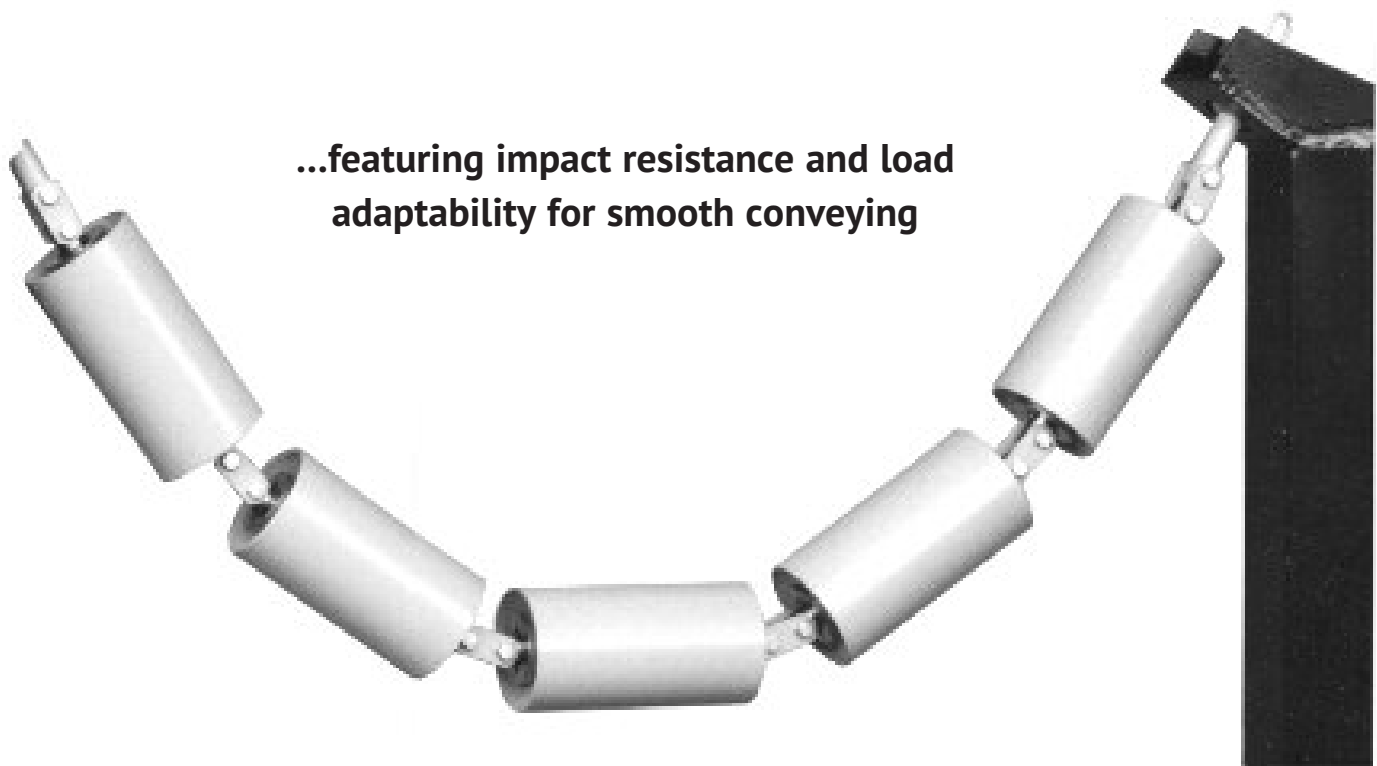

# 10° 2-Roll V-Return Idlers

40,000

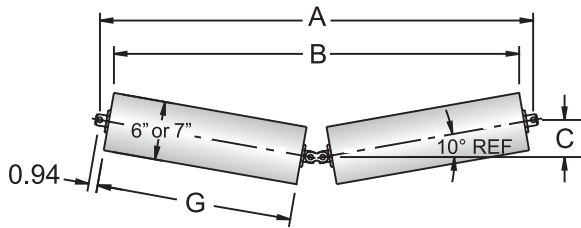

Belt width, inches	Dia.	Idler number	Idler weight, pounds	A	B	C	G
				Inches			
36	6"	40656-36	91	44.56	41.69	3.81	20.12
	7"	40756-36	102	44.56	41.50	3.81	20.12
42	6"	40656-42	106	51.88	48.94	4.44	23.81
	7"	40756-42	119	51.88	48.81	4.44	23.81
48	6"	40656-48	119	58.12	55.25	5.00	27.00
	7"	40756-48	133	58.12	55.06	5.00	27.00
54	6"	40656-54	137	66.75	63.88	5.81	31.38
	7"	40756-54	153	66.75	63.69	5.81	31.38
60	6"	40656-60	146	71.44	68.56	6.19	33.75
	7"	40756-60	163	71.44	68.38	6.19	33.75
72	6"	40656-72	173	84.50	81.62	7.31	40.38
	7"	40756-72	193	84.50	81.44	7.31	40.38
84	6"	40656-84	198	96.31	93.44	8.38	46.38
	7"	40756-84	220	96.31	93.25	8.38	46.38
96	6"	40656-96	228	110.94	108.06	9.69	53.81
	7"	40756-96	254	110.94	107.88	9.69	53.81

# 15° 2-Roll V-Return Idlers

40,000

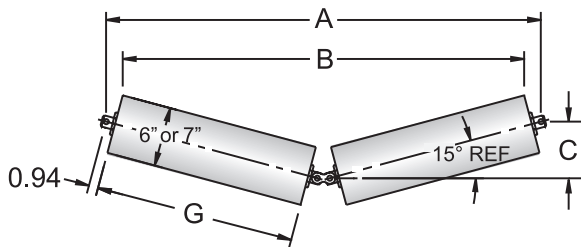

Belt width, inches	Dia.	Idler number	Idler weight, pounds	A	B	C	G
				Inches			
36	6"	40656-36	91	43.75	40.38	5.69	20.12
	7"	40756-36	102	43.75	40.12	5.69	20.12
42	6"	40656-42	106	50.88	47.50	6.62	23.81
	7"	40756-42	119	50.88	47.25	6.62	23.81
48	6"	40656-48	119	57.06	53.69	7.50	27.00
	7"	40756-48	133	57.06	53.44	7.50	27.00
54	6"	40656-54	137	65.50	62.12	8.62	31.38
	7"	40756-54	153	65.50	61.88	8.62	31.38
60	6"	40656-60	146	70.06	66.69	9.25	33.75
	7"	40756-60	163	70.06	66.44	9.25	33.75
72	6"	40656-72	173	82.88	79.50	10.94	40.38
	7"	40756-72	193	82.88	79.25	10.94	40.38
84	6"	40656-84	198	94.50	91.12	12.50	46.38
	7"	40756-84	220	94.50	90.88	12.50	46.38
96	6"	40656-96	228	108.81	105.50	14.44	53.81
	7"	40756-96	254	108.81	105.19	14.44	53.81



# 35° 3-Roll Troughing Idlers

## 40,000

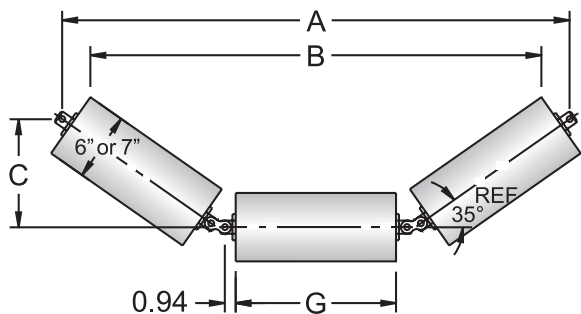

Belt width, inches	Dia.	Idler number	Idler weight, pounds	A	B	C	G
				Inches			
36	6"	40655-36	100	44.44	39.50	9.44	14.06
	7"	40755-36	112	44.44	38.94	9.44	14.06
42	6"	40655-42	112	49.69	44.75	10.62	16.06
	7"	40755-42	126	49.69	44.19	10.62	16.06
48	6"	40655-48	125	55.00	50.06	11.75	18.06
	7"	40755-48	140	55.00	49.50	11.75	18.06
54	6"	40655-54	137	60.44	55.50	12.94	20.12
	7"	40755-54	153	60.44	54.94	12.94	20.12
60	6"	40655-60	151	66.38	61.44	14.25	22.38
	7"	40755-60	169	66.38	60.88	14.25	22.38
72	6"	40655-72	179	78.56	73.62	16.88	27.00
	7"	40755-72	200	78.56	73.06	16.88	27.00
84	6"	40655-84	206	90.12	85.19	19.38	31.38
	7"	40755-84	230	90.12	84.62	19.38	31.38
96	6"	40655-96	233	102.00	97.06	22.00	35.88
	7"	40755-96	260	102.00	96.50	22.00	35.88

# 55° 5-Roll Impact Idlers

## 40,000

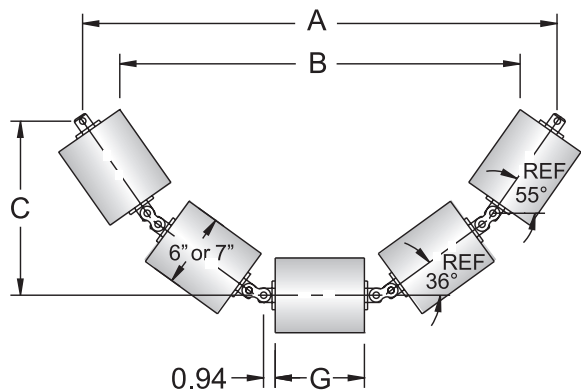

Belt width, inches	Dia.	Idler number	Idler weight, pounds	A	B	C	G
				Inches			
36	6"	40657-36	98	38.31	32.31	14.06	7.19
	7"	40757-36	111	38.31	31.50	14.06	7.19
42	6"	40657-42	111	43.19	37.25	15.88	8.50
	7"	40757-42	126	43.19	36.38	15.88	8.50
48	6"	40657-48	127	49.12	43.12	18.06	10.06
	7"	40757-48	143	49.12	42.25	18.06	10.06
54	6"	40657-54	139	53.31	47.38	19.69	11.19
	7"	40757-54	156	53.31	46.56	19.69	11.19
60	6"	40657-60	152	58.25	52.31	21.50	12.50
	7"	40757-60	171	58.25	51.44	21.50	12.50
72	6"	40657-72	179	68.12	62.19	25.19	15.12
	7"	40757-72	200	68.12	61.31	25.12	15.12
84	6"	40657-84	209	79.19	73.25	29.31	18.06
	7"	40757-84	233	79.19	72.38	29.31	18.06
96	6"	40657-96	229	86.94	81.00	32.25	20.12
	7"	40757-96	257	86.94	80.12	32.25	20.12

# 45°

## 3-Roll Troughing Idlers

70,000

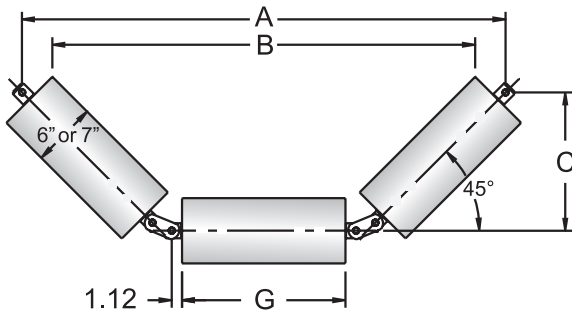

Belt width, inches	Dia.	Idler number	Idler weight, pounds	A	B	C	G
				Inches			
48	6"	70655-48	166	52.00	46.12	14.88	17.56
	7"	70755-48	180	52.00	54.44	14.88	17.56
54	6"	70655-54	182	56.94	51.12	16.31	19.62
	7"	70755-54	198	56.94	50.44	16.31	19.62
60	6"	70655-60	198	61.62	55.81	17.69	21.56
	7"	70755-60	215	61.62	55.12	17.69	21.56
72	6"	70655-72	231	71.31	65.44	20.56	25.56
	7"	70755-72	251	71.31	64.75	20.56	25.56
84	6"	70655-84	263	80.94	75.12	23.38	29.56
	7"	70755-84	286	80.94	74.44	23.38	29.56
96	6"	70655-96	296	90.62	84.81	26.19	33.56
	7"	70755-96	321	90.62	84.06	26.19	33.56

# 55°

## 5-Roll Impact Idlers

70,000

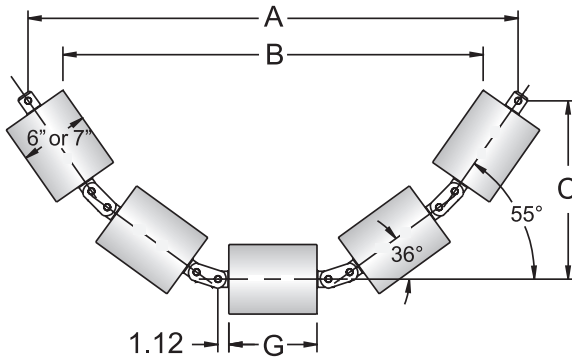

Belt width, inches	Dia.	Idler number	Idler weight, pounds	A	B	C	G
				Inches			
48	6"	70657-48	160	49.31	43.12	17.94	8.88
	7"	70757-48	174	49.31	42.31	17.94	8.88
54	6"	70657-54	177	54.00	47.81	19.69	10.12
	7"	70757-54	193	54.00	47.00	19.69	10.12
60	6"	70657-60	193	58.50	52.31	21.38	11.31
	7"	70757-60	210	58.50	51.50	21.38	11.31
72	6"	70657-72	226	67.69	61.50	24.81	13.75
	7"	70757-72	246	67.69	60.62	24.81	13.75
84	6"	70657-84	259	76.88	70.69	28.25	16.19
	7"	70757-84	282	76.88	69.81	28.25	16.19
96	6"	70657-96	292	86.00	79.81	31.69	18.62
	7"	70757-96	317	86.00	79.00	31.69	18.62

# 15°

## 2-Roll V-Return Idler

# 70,000

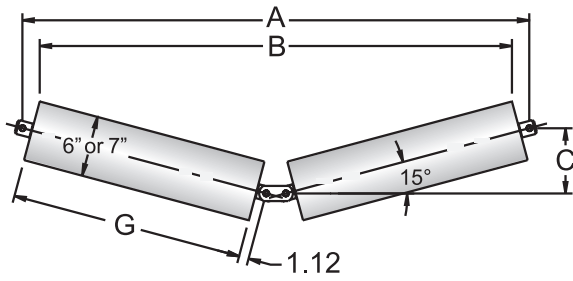

Belt width, inches	Dia.	Idler number	Idler weight, pounds	A	B	C	G
				Inches			
48	6"	70656-48	160	58.25	54.56	7.50	26.75
	7"	70756-48	173	58.25	54.31	7.50	26.75
54	6"	70656-54	176	64.06	60.31	8.31	29.75
	7"	70756-54	191	64.06	60.06	8.31	29.75
60	6"	70656-60	192	69.88	66.12	9.06	32.75
	7"	70756-60	209	69.88	65.88	9.06	32.75
72	6"	70656-72	225	81.44	77.75	10.62	38.75
	7"	70756-72	244	81.44	77.50	10.62	38.75
84	6"	70656-84	257	93.06	89.31	12.19	44.75
	7"	70756-84	279	93.06	89.06	12.19	44.75
96	6"	70656-96	290	104.62	100.94	13.75	50.75
	7"	70756-96	314	104.62	100.62	13.75	50.75

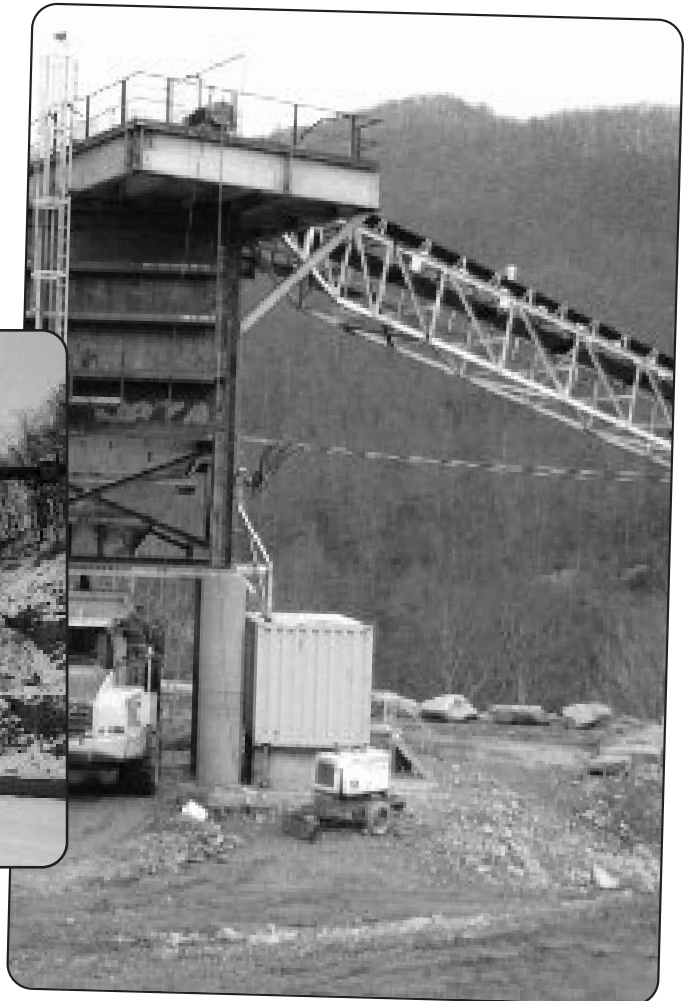

## Catenary Connecting Devices

The designs of support structures for Catenary Idlers are not limited. The Link-Belt range of standard designs of Catenary Connecting Devices accommodates most applications. Typical connecting devices are illustrated. Other designs are available upon request. Heavy-duty chain links on each end of the Catenary Idler Suspension Assembly compensate for variable distances between support structures.

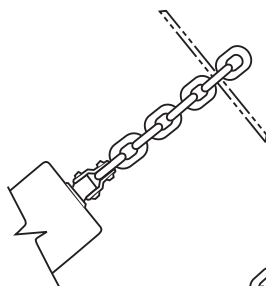

• for 3-roll assembly attachment A

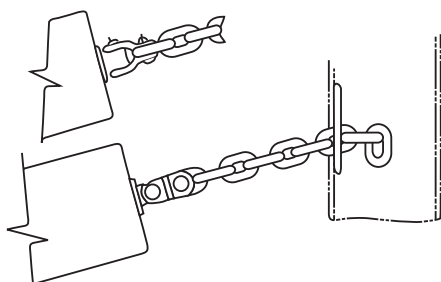
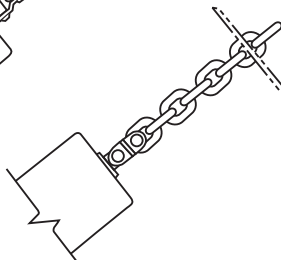

• for 2-roll v-return assembly attachment B

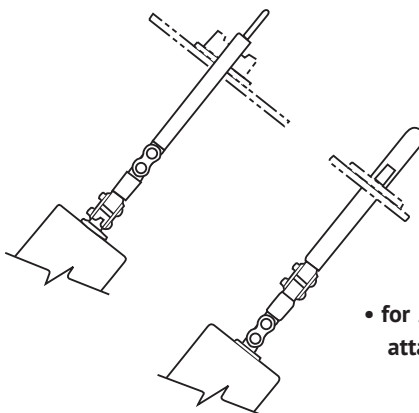

• for 5-roll impact assembly attachment C

## Catenary Quick Disconnect

The Quick Disconnect will permit dropping an idler assembly out of service without stopping the conveyor. A simple mechanical device facilitates quick operation.

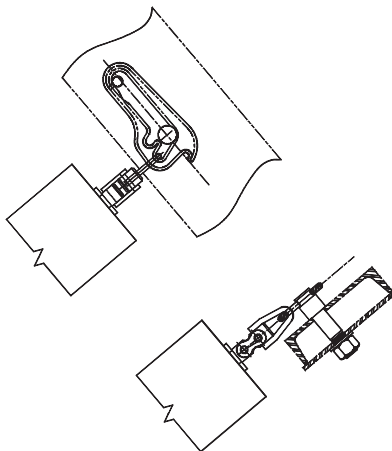

# CEMA C/D 3000 Truss Frame Idler

Syntron Material Handling continues to lead the industry with a commitment to produce the most innovative, specialized belt conveyor equipment available to assist you in solving your unique material handling requirements.

We are very proud of our patented “Link-Belt Truss Frame Idler” for CEMA D load requirements. Dimensionally interchangeable with all CEMA C/D Series idlers, the Syntron Material Handling Truss Idler features a lightweight frame member that is fabricated from round bar stock to reduce the frame weight by 50%. An added benefit of this truss frame design is a 40% increase in load rating as compared to the conventional CEMA D inverted angle frame. The design of the frame, with rounded surfaces and the lowest roll gap available (0.25 in), ensures against costly material spillage buildup around the idler that may impede production. The Link-Belt Truss Idler is available in a variety of materials: #304SS, #316SS and of course, carbon steel. This is especially critical in today’s markets for the handling of harsh chemicals, phosphate, salt, acids and many other corrosive materials that tend to shorten the life of your equipment. For these caustic applications we complete the offering by placing premium HDPE polyethylene rollers into the stainless steel or carbon steel frame. The polyethylene rollers greatly extend the life of your belt conveyor equipment while reducing costly maintenance and downtime.

Whether your goal is to reduce equipment weight or to extend equipment life subjected to a harsh material handling environment, the Link-Belt Truss Frame Idler is your ultimate solution.

For additional assistance in selecting the proper Truss Frame Idler to solve your problems, please contact your Syntron Material Handling Customer Service Representative at 1-800-356-4898.

\* See pages 90-93 for composite options.

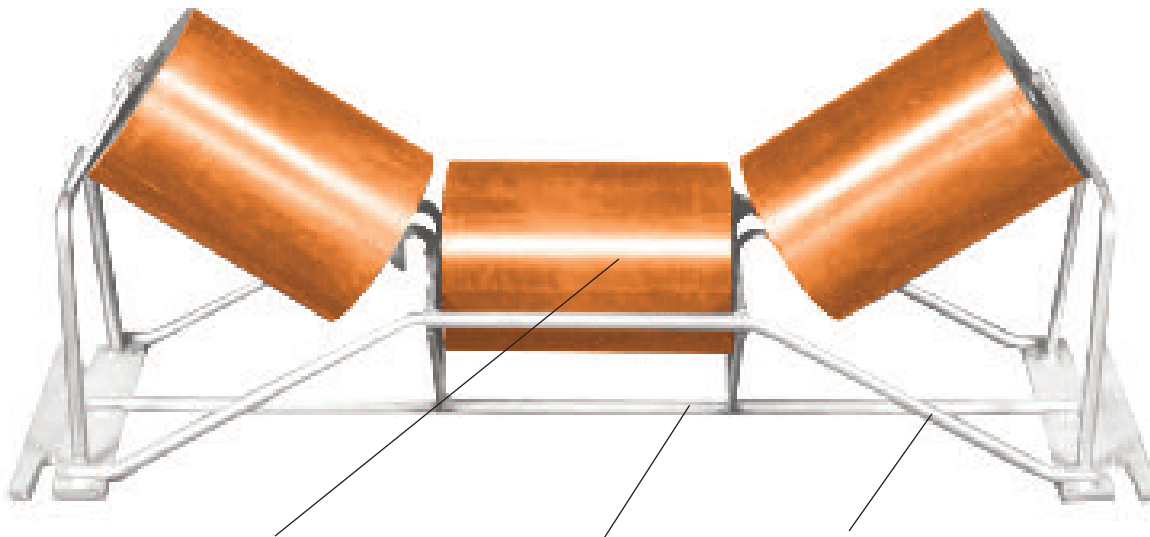

**Polyethylene/Composite rolls**

**Resists corrosion and material buildup**

**Frame options:**

- #304SS
- #316SS
- Carbon Steel

**Lightweight for simple installation**

# Conveyor Belt Alignment

**A belt conveyor which is properly designed, constructed, erected, and maintained theoretically will consistently run true without concern for belt misalignment. However, in actuality, properly aligned belts are normally the exception rather than the rule. The following belt training trouble-shooting guide is provided to assist you in your efforts to correct belt misalignment problems that invariably lead to premature failure of belting, idlers, and pulleys. Please follow these steps to ensure satisfactory performance of your belt conveyors:**

1. Square and level the head and tail pulleys with their axis at 90 degrees to the intended path of the belt.
2. Square all carrying and return idlers with the conveyor frame during the belt conveyor installation, be sure the idlers are in line and lie in the same horizontal plane, and secure all attachment bolts.
3. Level all frames to ensure a cross-section parallel to the ground plane. If one side of the conveyor frame is lower than the other, gravity will force the belt off-center.
4. The belt must be straight and the belt splice square. If side creep occurs only in the vicinity of the belt splice, the splice may not be square with the belt. In general, if detraining follows the belt movement, there is a problem with the belt. If it remains in one general vicinity, there are other problems with the conveyor. Some new belts may tend to wander to one side, in a certain position or portions of their length, because of temporary lateral mal-distributions of tension. Operation of the belt under tension corrects this condition in practically all cases. Use of self-aligning idlers will aid in making the correction.
5. The belt should make constant contact with all troughed idler rollers.
6. Conveyed material should always be centrally loaded onto the belt by means of chutework, loading hoppers, skirtboarding, etc.

**There may be occasion when the above procedure is not sufficient and the belt detrains to one side. The following corrective measures may be initiated to prevent side movement:**

1. While running the belt at the lowest speed possible, find the point of maximum side motion. The idler preceding this point along the direction of belt travel can be adjusted to minimize side movement. The belt may be centered by pivoting, or “knocking” ahead (in the direction of belt travel) the end of the idler to which the belt runs. Shifting idlers in this way should be spread over some length of the conveyor preceding the region of trouble. Once the belt is centered, increase belt speed and load the belt with material. Continue adjusting until normal operating conditions do not cause the belt to misalign.
2. Recheck pulley alignment to ensure that they are level and with their axes at 90 degrees to the intended path of the belt. Head and tail pulleys should not be shifted in an effort to center the belt with the exception of the snub pulleys which may have their axes shifted when other training measures have failed.
3. Training idlers are not intended to compensate for a belt that has been poorly aligned, or to correct for off-center loading conditions. However, both troughed training and return training positive action idlers are recommended for lengthy conveyors to assist in correcting and recentering occasional wandering belts. They should normally be located 50 feet from terminal pulleys and spaced 50 to 100 feet. Free rotation of the trainer’s vertical actuating rolls is essential for proper operation of the idler. Please refer to the index page in this publication for Syntron Material Handling model numbers and complete dimensional information regarding Link-Belt positive action training idlers.
4. Recheck conveyor belt to verify that all splices are correct and square.
5. If the above steps do not resolve the belt training issues, the conveyor should be laser aligned and corrective action taken based upon the survey data.

# Syntron Material Handling MHS Powder Coat Painting Process Specification

All Syntron Material Handling Idler rollers and frames are processed through an automated state of the art surface treatment and painting process. The parts begin their surface treatment by hanging bare metal parts on a powered chain conveyor system. The parts pass through a three stage Iron Phosphate Conversion Coating Washer System.

The iron phosphate system is a chemical conversion coating that transforms the surface of the base metal into a nonmetallic crystalline coating. This crystalline coating applied as an interface between the bare metal and the finish top coat of paint can significantly increase corrosion resistance even though it is micro thin.

Within the first stage, the parts are cleaned with an incorporated detergent system to clean and apply an iron phosphate primer coating all in one step. To allow the coating to form, the bath temperature must be maintained at 100-140 degrees Fahrenheit, and the parts remain inside the bath for a minimum of 5 minutes. The second and third stages are fresh water rinse baths that remove all unwanted impurities from all part surfaces.

The conveyor continues through a flash drying process and the parts are immediately painted by an automated electrostatic paint application system. A polyester TGIC paint is normally applied but virtually any powder paint can be applied including Powder Epoxy. Film thicknesses are typically 2 to 5 mils.

**Syntron Material Handling standard paint is a Polyester TGIC Corvel Grey powder. The physical properties of the paint are:**

Specific Gravity:	Calculated	1.58
Gloss:	(ASTM D523)	50-60% @ 70%
Adhesion Cross Hatch:	(ASTM D3359)	Pass
MEK Resistance:	(30 sec rub)	50+ DR
Salt Spray Resistance:	(ASTM B117)	500 HRS
Flexibility Conical Mandrel:	(ASTM D522)	¼" Pass
Pencil Hardness:	(ASTM D3363)	Record
Impact Resistance:	(ASTM D2794)	160/160 in lbs

The automated conveyor passes through a natural gas-fired curing oven that maintains the steel temperature at 300 degrees Fahrenheit for a minimum of 10 minutes. After a cool down process, the parts are removed to continue in the production of the finished idler products.



# Quality Assurance Testing

## Load Testing

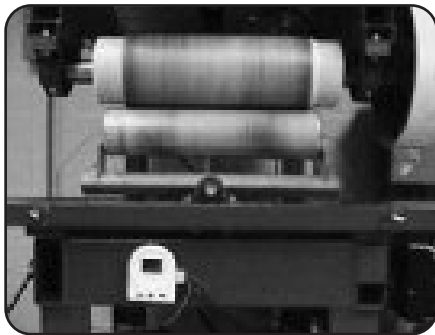

Rotates test roll under load. Bearing temperatures are monitored to indicate failure.

## Roll Imbalance Testing

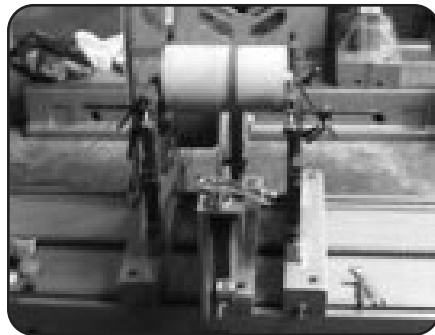

Rolls are tested for imbalance per ISO 1940.

## Oilsand Slurry Seal Testing



Mixture of oilsand, blasting sand and gear oil used as test medium. Screw agitators pull slurry toward seals. Inspection ports allow easy inspection of seal failure.

## Water Resistance Testing



Rolls are weighed. Rolls are partially submerged and rotated. Rolls are weighed again to determine if any water bypassed the seal. This test is per DIN 22112-3.

## Roll Resistance Testing



Rolls are placed in vee blocks. As the roll is rotated, the resistance needed to keep the shaft stationary is measured per DIN 22112-3.

## Roll Concentricity Testing

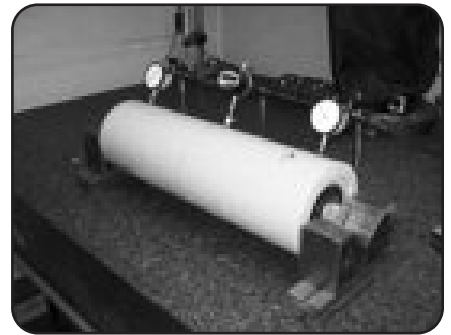

Roll concentricity is tested in the center and near each end per DIN 22112-3.

## To obtain a Service & Safety Manual:

The Syntron Material Handling Service & Safety Manual is available for download at:  
[www.syntronmh.com](http://www.syntronmh.com)

This manual can also be distributed free of charge via postal service or electronic mail. Contact our customer service department at 1-800-356-4898 and reference "SM-Idlers".









# **Syntron** Material Handling

## **Corporate Office**

P.O. Box 1370

Tupelo, Mississippi 38802

Phone: 662.869.5711

Fax: 662.869.7449

## **Proven Engineered Products – Complete Material Handling Solutions**

**Syntron<sup>®</sup>**  
**Link-Belt<sup>®</sup>**

### **Saltillo**

2730 Hwy 145 South

Saltillo, Mississippi 38866

Phone: 662.869.5711

Fax: 662.869.7493

Toll Free: 800.356.4898

[info@syntronmh.com](mailto:info@syntronmh.com)

### **Changshu**

#2 Road No. 1

Changshu Export Processing Zone

Changshu, Jiangsu, China 215513

Phone: +86 0512.52299002

Fax: +86 0512.52297228

[info@syntronmh.com](mailto:info@syntronmh.com)